

COLOUR VARIATIONS		
PART NUMBER	PLASTIC COMPONENTS	EXTRUSION
WT	WHITE	ANODISED SILVER
BK	BLACK	ANODISED SILVER
BK/BK	BLACK	POWDERCOATED BLACK MANNEX
WT/WT	WHITE	POWDERCOATED WHITE SATIN
WT/WM	WHITE	POWDERCOATED WHITE MANNEX

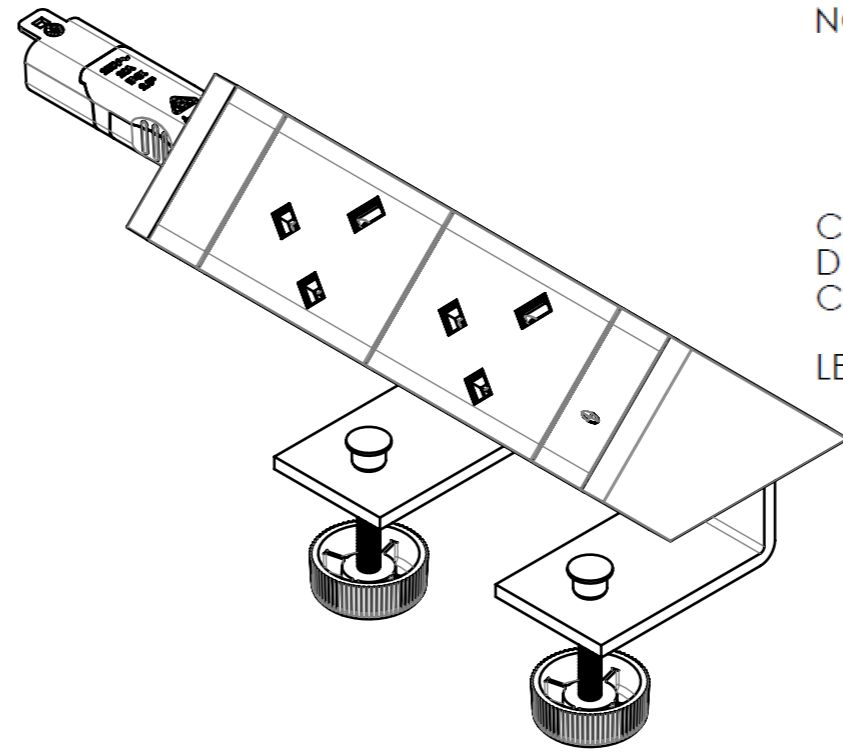

NOTE:

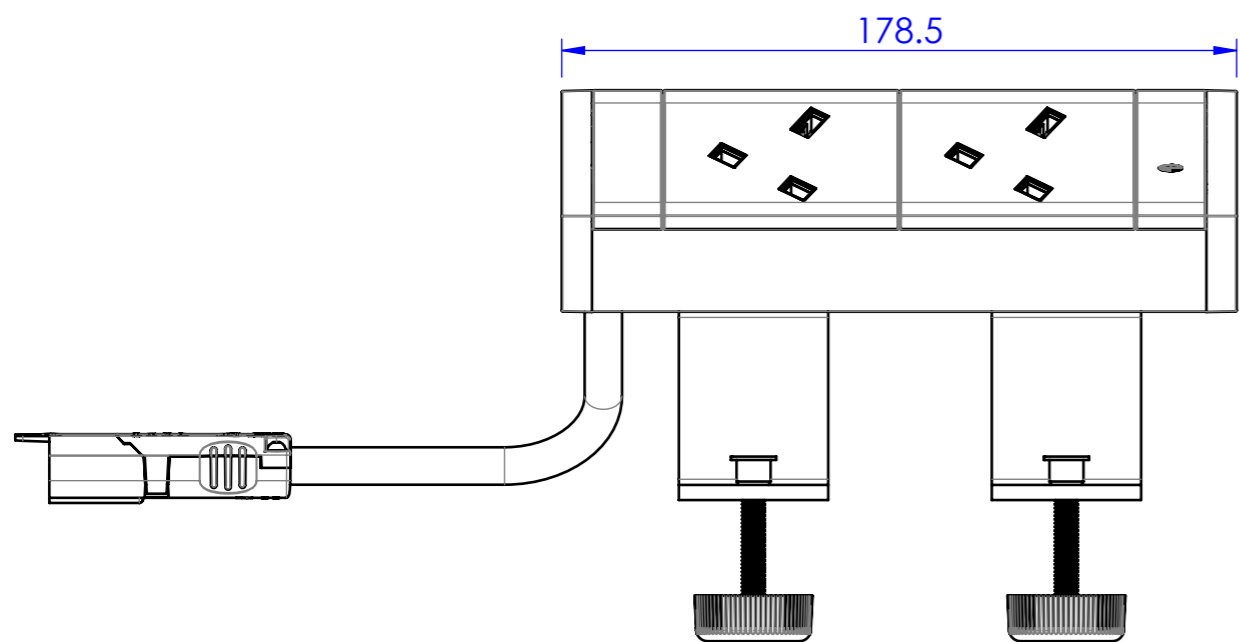
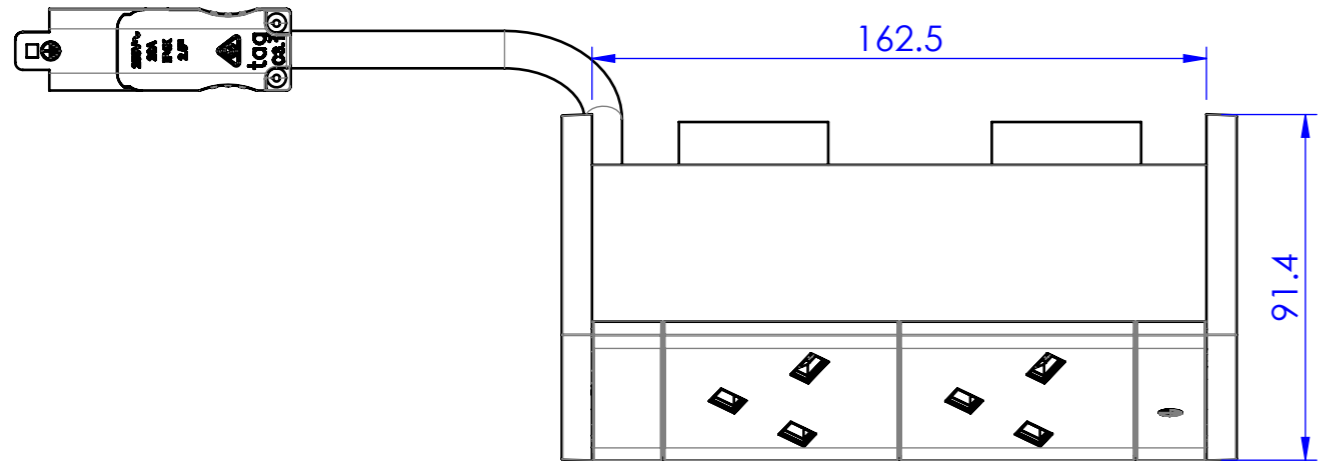
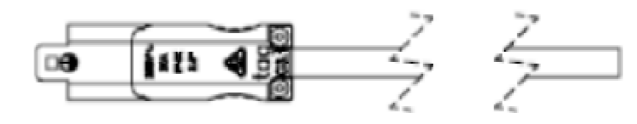

CABLE TYPE: 1.5MM
 DESCRIPTION: C-CONNECTOR LEAD
 COLOUR: WHITE OR BLACK
 (REFER TO PURCHASE ORDER)

LENGTH (mm):

xx	LENGTH (mm)
05	500
10	1000
15	1500
20	2000
25	2500
30	3000
35	3500
40	4000
45	4500
50	5000

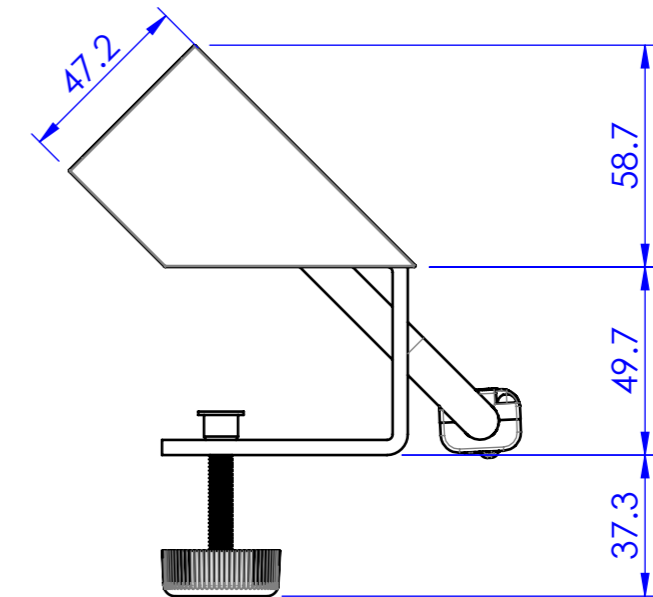

PART NUMBER: NKA02CxxXX
 NOTE - xx - LENGTH - 05 / 10 / 15 / 20 / 25 / 30 / 35 / 40 / 45 / 50
 XX - COLOUR - WT / BK / (BK/BK) / (WT/WT) / (WT/WM)

CUSTOMER SIGNATURE:	TOLERANCES UNLESS OTHERWISE STATED: X ±0.5 X.X ±0.2 X.XX ±0.1 X.XXX ±0.05 ANG ±0.5°	 CMS Electracom		COPYRIGHT © 2015	
MATERIAL: POLYCARBONATE / ALUMINIUM		TITLE: ATHENA 2 WITH NK1802			
FINISH: FINE EDM / ANODISED (POWDER COAT)		DRAWING: LU34606			
COLOUR: REFER TABLE		REV: 2			
THIS DRAWING & ASSOCIATED CAD FILES ARE ISSUED IN THE STRICTEST CONFIDENCE AND ARE ONLY TO BE USED IN THE COMMERCIAL INTERESTS OF CMS ELECTRACOM PTY LTD		DRAWN IN mm TO AS1100 DO NOT SCALE		A3	
REVISIONS		SCALE 1:2		SHEET 1 OF 2	

REV	DESCRIPTION	DATE	DRWN	APPV
2	RELEASED FOR PRODUCTION	24/2/2020	JB	RG
1	RELEASED FOR QUOTATION - NOT FOR PRODUCTION	24/2/2020	JB	RG