

COLOUR VARIATIONS		
PART NUMBER	PLASTIC COMPONENTS	EXTRUSION
WT	WHITE	ANODISED SILVER
BK	BLACK	ANODISED SILVER
BK/BK	BLACK	POWDERCOATED BLACK MANNEX
WT/WT	WHITE	POWDERCOATED WHITE SATIN
WT/WM	WHITE	POWDERCOATED WHITE MANNEX

NOTE:

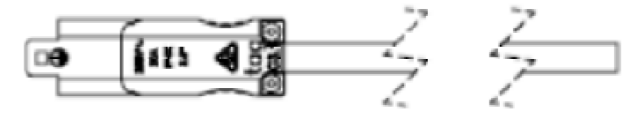

CABLE TYPE: 3 CORE x 1.5mm<sup>2</sup>  
 DESCRIPTION: C-CONNECTOR LEAD  
 COLOUR: WHITE OR BLACK  
 (REFER TO PURCHASE ORDER)

LENGTH (mm):	xx	LENGTH (mm)
	05	500
	10	1000
	15	1500
	20	2000
	25	2500
	30	3000
	35	3500
	40	4000
	45	4500
	50	5000

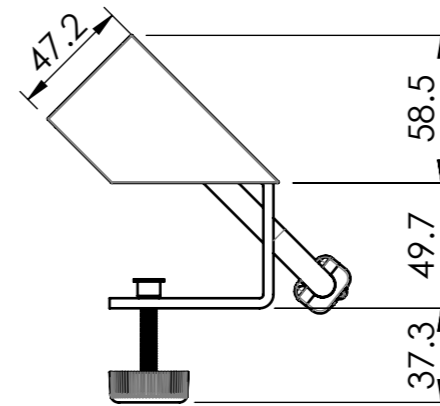
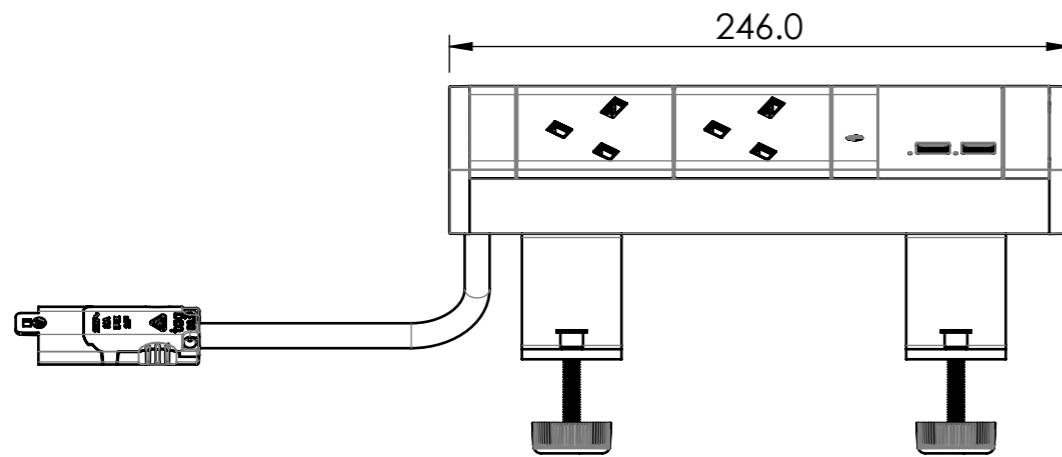
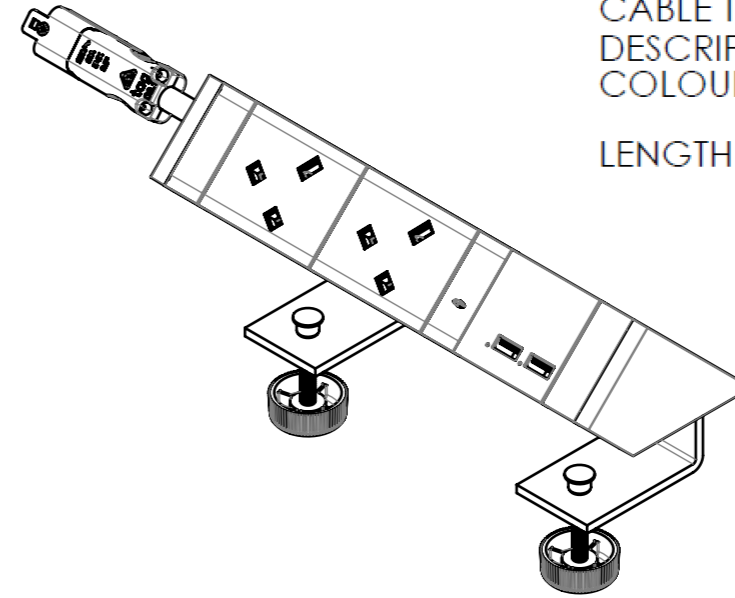
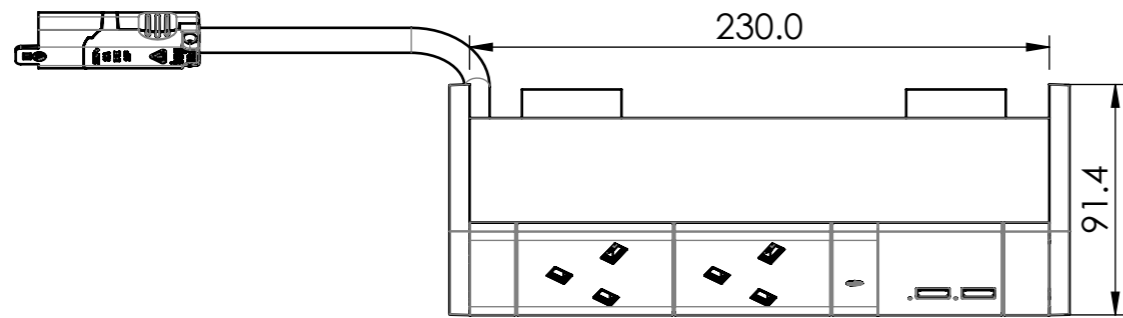

**PART NUMBER:** NKA02UAA3CxxXX

NOTE - xx - LENGTH - 05 / 10 / 15 / 20 / 25 / 30 / 35 / 40 / 45 / 50  
 XX - COLOUR - WT / BK / (BK/BK) / (WT/WT) / (WT/WM)

<b>CUSTOMER SIGNATURE:</b>	<b>TOLERANCES UNLESS OTHERWISE STATED:</b>  X ±0.5 X.X ±0.2 X.XX ±0.1 X.XXX ±0.05 ANG ±0.5°
<b>MATERIAL:</b> POLYCARBONATE / ALUMINIUM	
<b>FINISH:</b> FINE EDM / ANODISED (POWDER COAT)	
<b>COLOUR:</b> REFER TABLE	
THIS DRAWING & ASSOCIATED CAD FILES ARE ISSUED IN THE STRICTEST CONFIDENCE AND ARE ONLY TO BE USED IN THE COMMERCIAL INTERESTS OF CMS ELECTRACOM PTY LTD	

TOLERANCES UNLESS OTHERWISE STATED:

X ±0.5  
 X.X ±0.2  
 X.XX ±0.1  
 X.XXX ±0.05  
 ANG ±0.5°



**CMS Electracom** COPYRIGHT © 2015

**TITLE:** ATHENA 2 WITH NK1802 + 1 NK18UAA3

**DRAWING:** LU37550

**REV:** 1

**A3**

SCALE 1:3

SHEET 1 OF 2

1	RELEASED FOR PRODUCTION	13/1/2021	JB	RG
REV	DESCRIPTION	DATE	DRWN	APPV
	REVISIONS			