

COLOUR VARIATIONS		
PART NUMBER	PLASTIC COMPONENTS	EXTRUSION
WT	WHITE	ANODISED SILVER
BK	BLACK	ANODISED SILVER
BK/BK	BLACK	POWDERCOATED BLACK MANNEX
WT/WT	WHITE	POWDERCOATED WHITE SATIN
WT/WM	WHITE	POWDERCOATED WHITE MANNEX

NOTE:

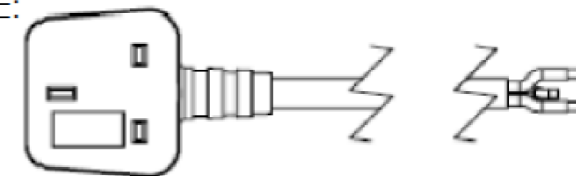

CABLE TYPE: 1.5MM
 DESCRIPTION: BRITISH 13A PLUG LEAD
 COLOUR: WHITE OR BLACK
 (REFER TO PURCHASE ORDER)
 LENGTH (mm):

xx	LENGTH (mm)
05	500
10	1000
15	1500
20	2000
25	2500
30	3000
35	3500
40	4000
45	4500
50	5000

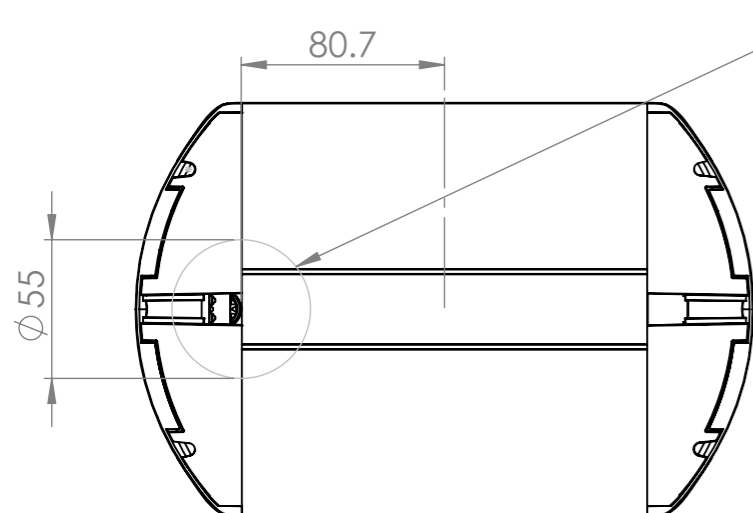
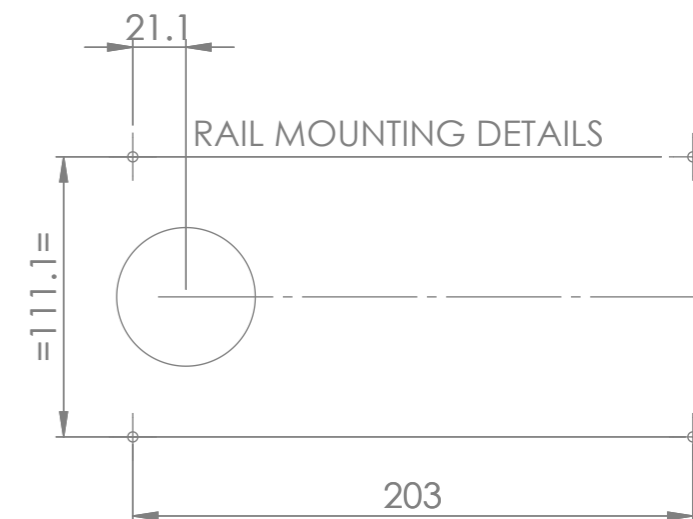
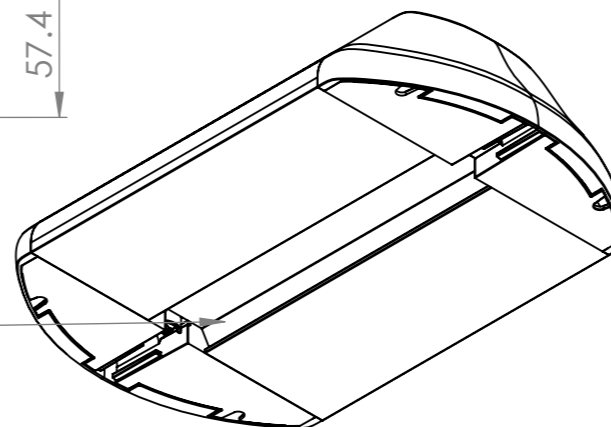
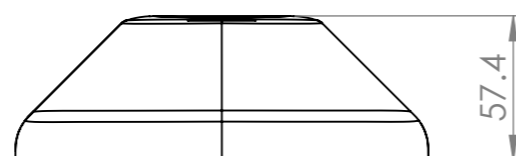
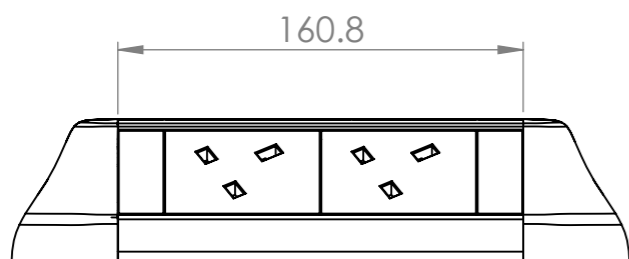
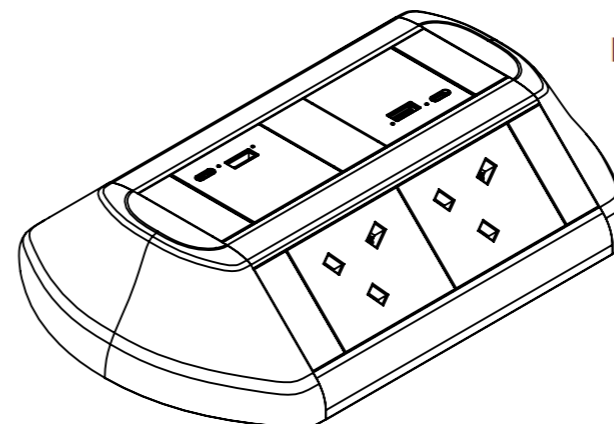
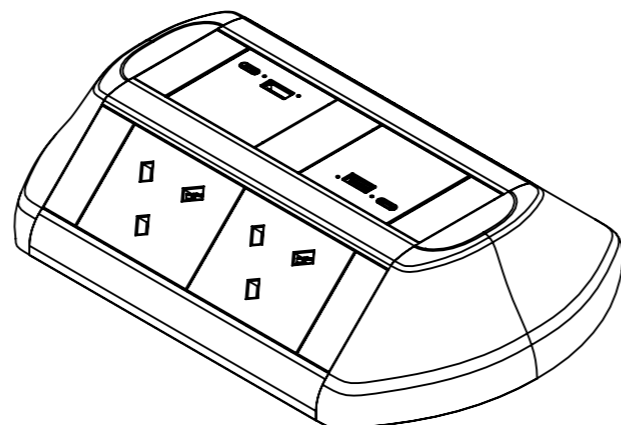
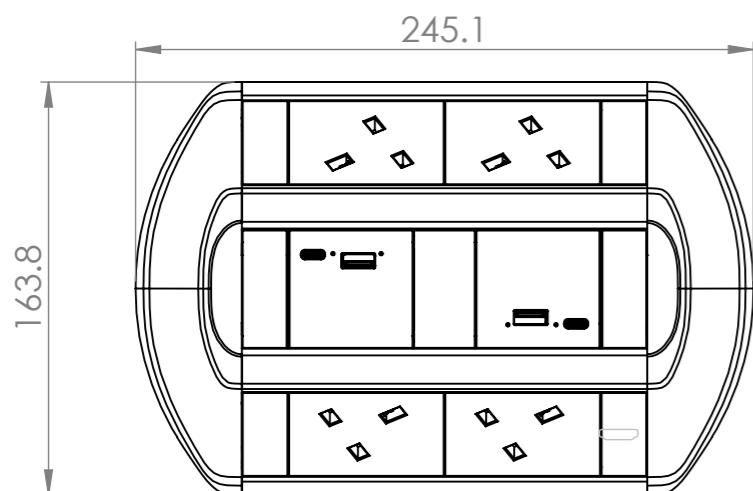

CUTOUT TO SUIT POWER CABLE THROUGH DESK

PART NUMBER: NKOD04U2AC3GxxXX/XX

NOTE - xx - LENGTH - 05 / 10 / 15 / 20 / 25 / 30 / 35 / 40 / 45 / 50
 XX - COLOUR - WT / BK / (BK/BK) / (WT/WT) / (WT/WM)

CUSTOMER SIGNATURE:	TOLERANCES UNLESS OTHERWISE STATED: X ±0.5 X.X ±0.2 X.XX ±0.1 X.XXX ±0.05 ANG ±0.5°
MATERIAL: P.C / ALUMINIUM	
FINISH: TEXTURED / ANODISED (POWDERCOAT)	
COLOUR: REFER TABLE	
THIS DRAWING & ASSOCIATED CAD FILES ARE ISSUED IN THE STRICTEST CONFIDENCE AND ARE ONLY TO BE USED IN THE COMMERCIAL INTERESTS OF CMS ELECTRACOM PTY LTD	

DRAWN IN mm TO AS1100 DO NOT SCALE



TITLE:
 ODYSSEY WITH 4 GPO + 2
 NK18UAC3FL

DRAWING: LU38058	REV: 2	A3
SCALE 1:3	SHEET 1 OF 2	

REV	DESCRIPTION	DATE	DRWN	APPV
2	RELEASED FOR PRODUCTION	22/4/2021	JB	RG
1	RELEASED FOR QUOTATION NOT FOR PRODUCTION	1/11/2019	JB	AP
REVISIONS				