

**FACTORY ONLY INSERTABLE MODULES
REFER PAGE 2 FOR MODULE
CONFIGURATION**

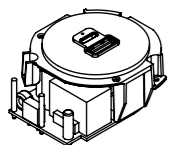

30W USB AC MODUAL = U

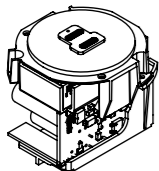

65W USB CC MODUAL = W2

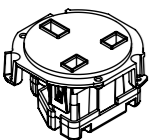

UK NON-FUSED OUTLET = C

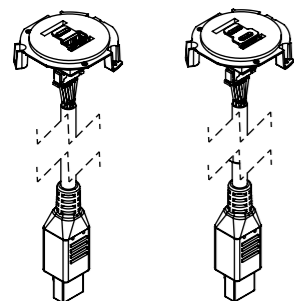

100W USB: A+C = V OR C+C = K
118W USB: A+C = Q OR C+C = M
140W USB: A+C = 7 OR C+C = S



HELISTAND (15W) WIRELESS CHARGER = P

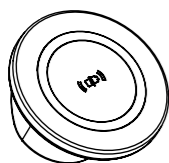

HELIPAD (15W) MAGNETIC WIRELESS CHARGER = J3

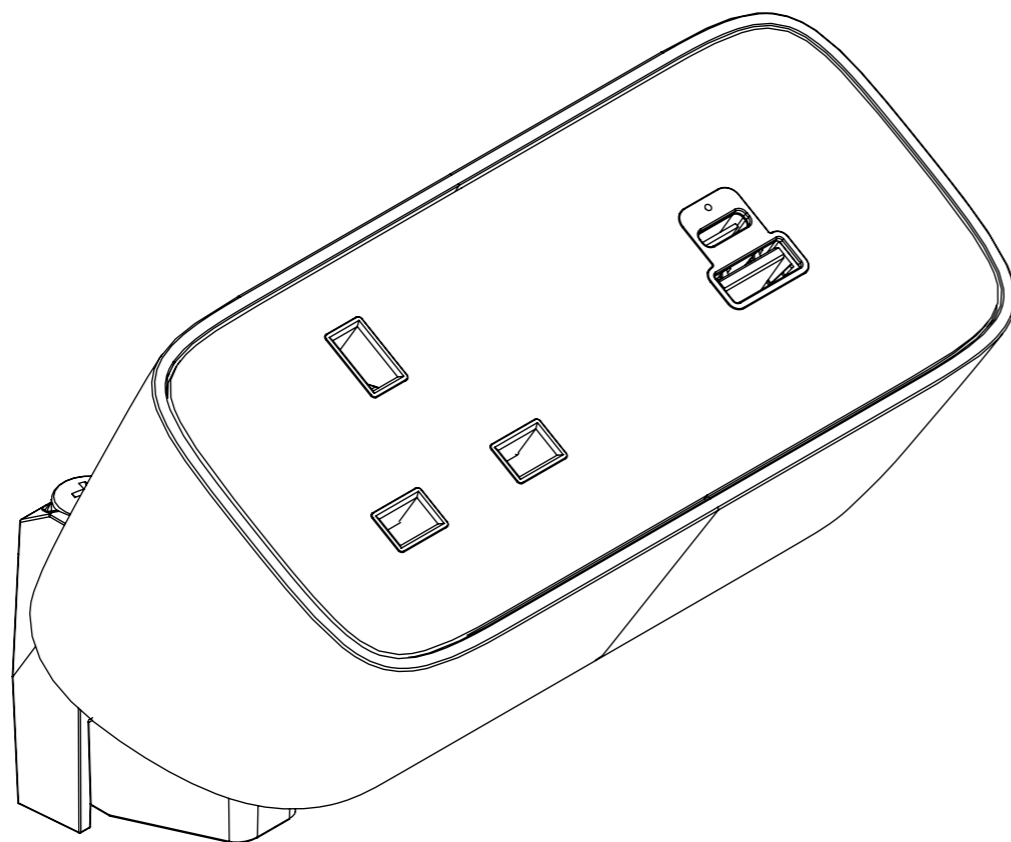

ABOVE DESK CLAMP

MIN TABLE THICKNESS: 20MM
MAX TABLE THICKNESS 32MM

NOTE:
TABLE SCALLOP OF **40mm MINIMUM REQUIRED** WHEN USING HELISTAND & PRIVACY SCREEN TO ALLOW ADDITIONAL SPACE FOR LARGE PHONES

PRIVACY SCREEN BETWEEN DESKS

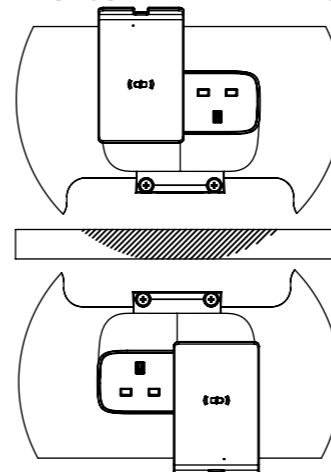

40
MINIMUM SCALLOP DISTANCE TO PRIVACY SCREEN

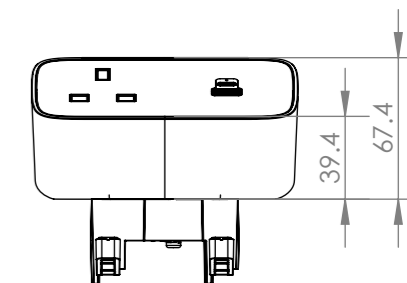
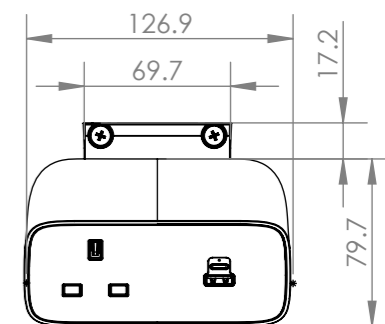
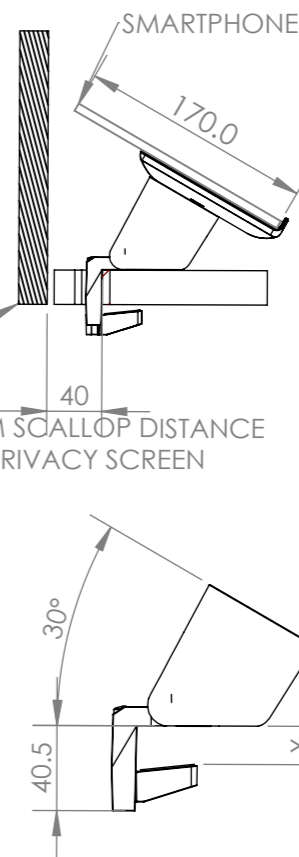

**UNDER DESK CLAMP
COMPATIBLE MOUNTING
SCREWS: 4G, 6G**

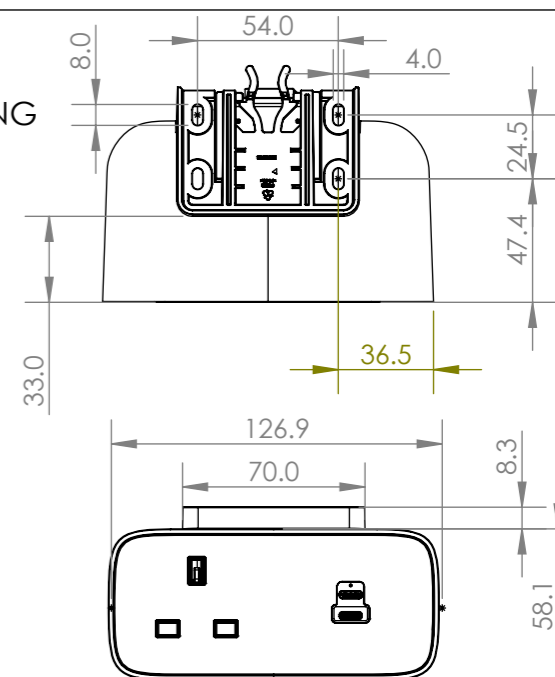
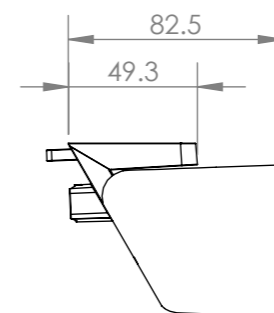

REV	DESCRIPTION	DATE	DRWN	APPV
5	"B" CORRECTED TO "G" FOR LEAD TYPE	18/3/2026	JB	RG
4	DRAWING FORMAT UPDATED	9/3/2026	JB	RG
3	NEW CONFIGURATIONS ADDED	12/4/2024	JB	RG
2	SCREW NOTE ADDED FOR USE OF TYPE 25 OR TYPE B	29/7/2022	JB	RG
1	RELEASED FOR PRODUCTION	21/6/2022	JB	RG
REVISIONS				

CUSTOMER SIGNATURE:	
MATERIAL:	PC FR
FINISH:	FINE EDM / POLISHED / FABRIC
COLOUR:	REFER TABLE
THIS DRAWING & ASSOCIATED CAD FILES ARE ISSUED IN THE STRICTEST CONFIDENCE AND ARE ONLY TO BE USED IN THE COMMERCIAL INTERESTS OF CMS ELECTRACOM PTY LTD	

TOLERANCES UNLESS OTHERWISE STATED:

X ±0.5
X.X ±0.2
X.XX ±0.1
X.XXX ±0.05
ANG ±0.5°

DRAWN IN mm TO AS1100 DO NOT SCALE



CMS Electracom COPYRIGHT © 2020

TITLE:
VIVA DUO XL UK NON-FUSED CONFIGURATIONS

DRAWING:
LU39681

REV:
5 **A3**

SCALE 1:2

SHEET 1 OF 12

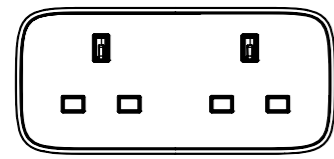

VD*CCXxxXX

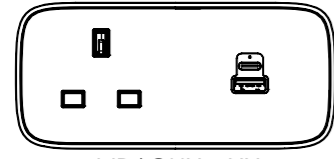

VD*CUXxxXX

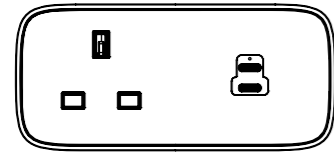

VD*CW2XxxXX

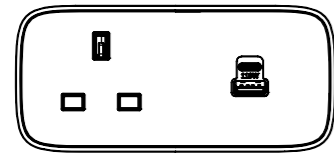

VD*C1XxxXX

ONLY AVAILABLE IN ABOVE DESK CLAMP

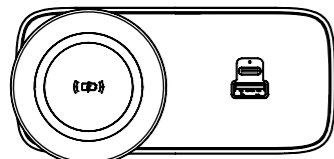

VD*J3UXxxXX

ONLY AVAILABLE IN ABOVE DESK CLAMP

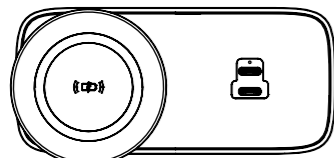

VD*J3W2XxxXX

ONLY AVAILABLE IN ABOVE DESK CLAMP

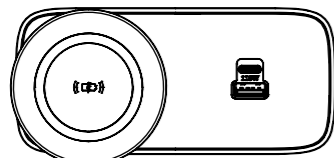

VD*J31XxxXX

ONLY AVAILABLE IN ABOVE DESK CLAMP

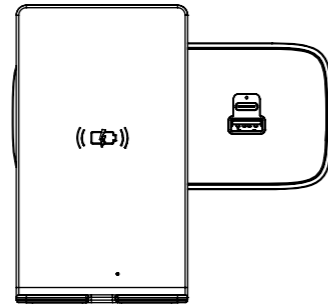

VD*PUXxxXX

ONLY AVAILABLE IN ABOVE DESK CLAMP

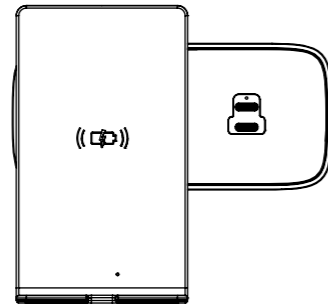

VD*PW2XxxXX

ONLY AVAILABLE IN ABOVE DESK CLAMP

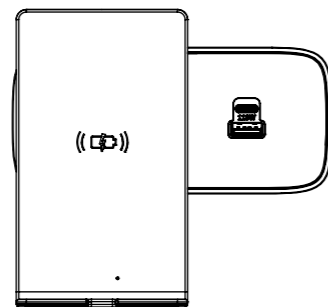

VD*P1XxxXX

ONLY AVAILABLE IN ABOVE DESK CLAMP

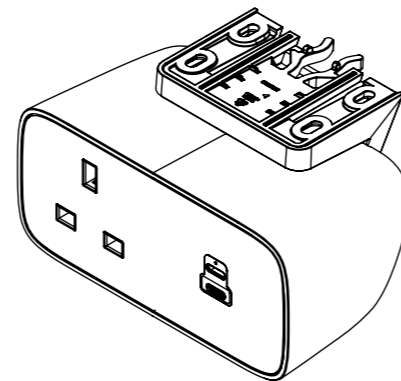

Z = UNDER DESK CLAMP

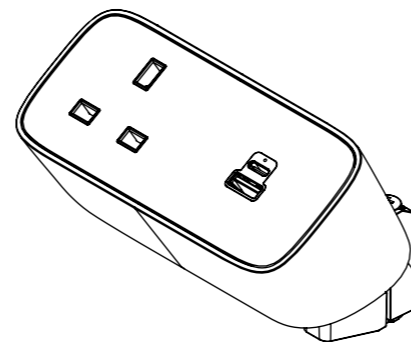

S= ABOVE DESK CLAMP

NOTE:

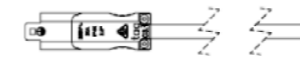

CABLE TYPE: 3 CORE x 1.5mm²
DESCRIPTION: C-CONNECTOR LEAD
COLOUR: WHITE OR BLACK
(REFER TO PURCHASE ORDER)

LENGTH (mm):	xx	LENGTH (mm)
	05	500
	10	1000
	15	1500
	20	2000
	25	2500
	30	3000
	35	3500
	40	4000
	45	4500
	50	5000

NOTE:



CABLE TYPE: 3 CORE x 1.5mm²
DESCRIPTION: GST PLUG LEAD
COLOUR: WHITE OR BLACK
(REFER TO PURCHASE ORDER)

LENGTH (mm):	xx	LENGTH (mm)
	05	500
	10	1000
	15	1500
	20	2000
	25	2500
	30	3000
	35	3500
	40	4000
	45	4500
	50	5000

NOTE:

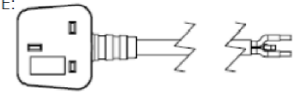

CABLE TYPE: 3 CORE x 1.5mm²
DESCRIPTION: BRITISH 13A PLUG LEAD
COLOUR: WHITE OR BLACK
(REFER TO PURCHASE ORDER)

LENGTH (mm):	xx	LENGTH (mm)
	05	500
	10	1000
	15	1500
	20	2000
	25	2500
	30	3000
	35	3500
	40	4000
	45	4500
	50	5000

COLOUR VARIATIONS	
PART NUMBER	DESCRIPTION
W	WHITE BODY & CLAMP
B	BLACK BODY & CLAMP
1	WHITE DECAL GLOSS
2	WHITE DECAL MATT
3	BLACK DECAL GLOSS
4	BLACK DECAL MATT
FABRIC FINISH REFER TO LU41144	
A	FABRIC COLOUR 1 - VANILA
B	FABRIC COLOUR 2 - SMOKE
C	FABRIC COLOUR 3 - IRON FORMERLY KNOWN AS CHARCOAL
D	FABRIC COLOUR 4 - CHARCOAL FORMERLY KNOWN AS BLACK

PART NUMBER: (REFER CONFIGURATION)xxXX



NOTE - * - CLAMP TYPE - (S = ABOVE DESK OR Z = UNDER DESK)

1 - USB (V = 100W SUB A+C, K = C+C OR Q = 118 USB A+C, M = C+C OR Y = 140W USB A+C, S = C+C)

X - LEAD TYPE (BS PLUG = G), (GST CONNECTOR = W), (C3.1 CONNECTOR = C)

xx - LENGTH - 05 / 10 / 15 / 20 / 25 / 30 / 35 / 40 / 45 / 50

XX - COLOUR - W / B + 1 / 2 / 3 / 4 + (OPTIONAL) A / B / C / D

CUSTOMER SIGNATURE:	TOLERANCES UNLESS OTHERWISE STATED:	 CMS Electracom COPYRIGHT © 2020
MATERIAL: PC FR	X ±0.5 X.X ±0.2 X.XX ±0.1 X.XXX ±0.05 ANG ±0.5°	
FINISH: FINE EDM / POLISHED / FABRIC		TITLE: VIVA DUO XL UK NON-FUSED CONFIGURATIONS
COLOUR: REFER TABLE		DRAWING: LU39681
THIS DRAWING & ASSOCIATED CAD FILES ARE ISSUED IN THE STRICTEST CONFIDENCE AND ARE ONLY TO BE USED IN THE COMMERCIAL INTERESTS OF CMS ELECTRACOM PTY LTD	DRAWN IN mm TO AS1100 DO NOT SCALE 	REV: 5
		A3
		SCALE 1:2
		SHEET 2 OF 12