

COLOUR VARIATIONS		
PART NUMBER	PLASTIC COMPONENTS	EXTRUSION
WT	WHITE	ANODISED SILVER
BK	BLACK	ANODISED SILVER
BK/BK	BLACK	POWDERCOATED BLACK MANNEX
WT/WT	WHITE	POWDERCOATED WHITE SATIN
WT/WM	WHITE	POWDERCOATED WHITE MANNEX

NOTE:



CABLE TYPE: 3 CORE x 1.5mm<sup>2</sup>  
 DESCRIPTION: C-CONNECTOR LEAD  
 COLOUR: WHITE OR BLACK  
 (REFER TO PURCHASE ORDER)

LENGTH (mm):	xx	LENGTH (mm)
	05	500
	10	1000
	15	1500
	20	2000
	25	2500
	30	3000
	35	3500
	40	4000
	45	4500
	50	5000

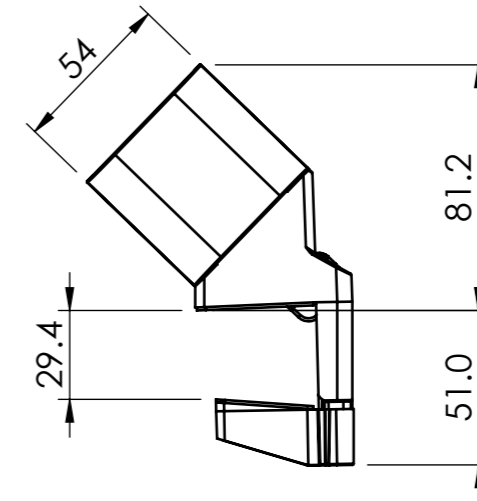
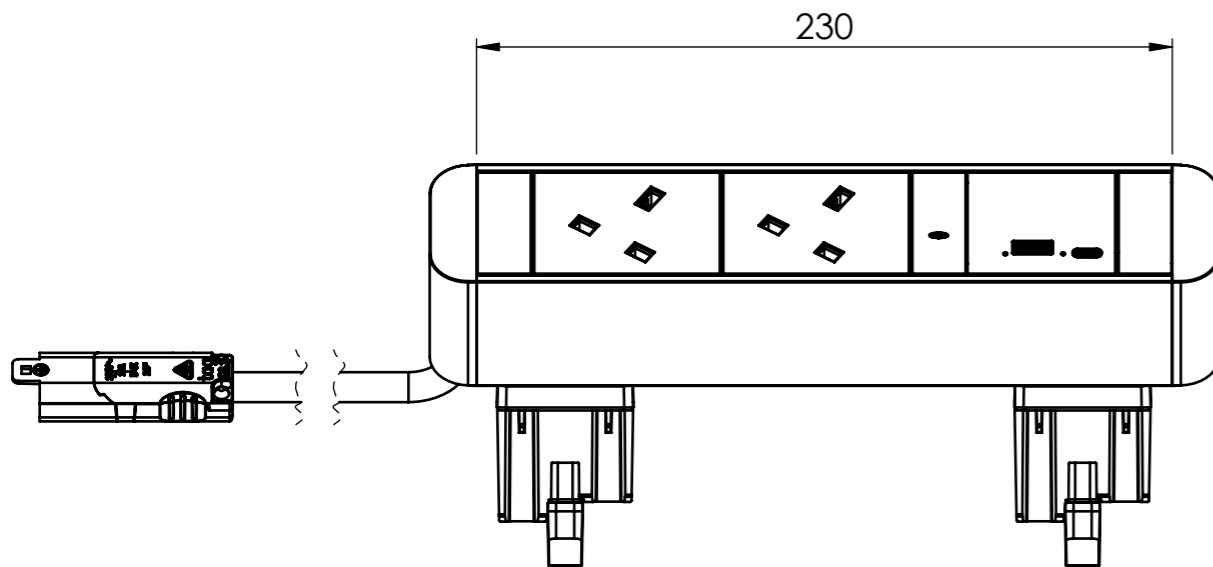
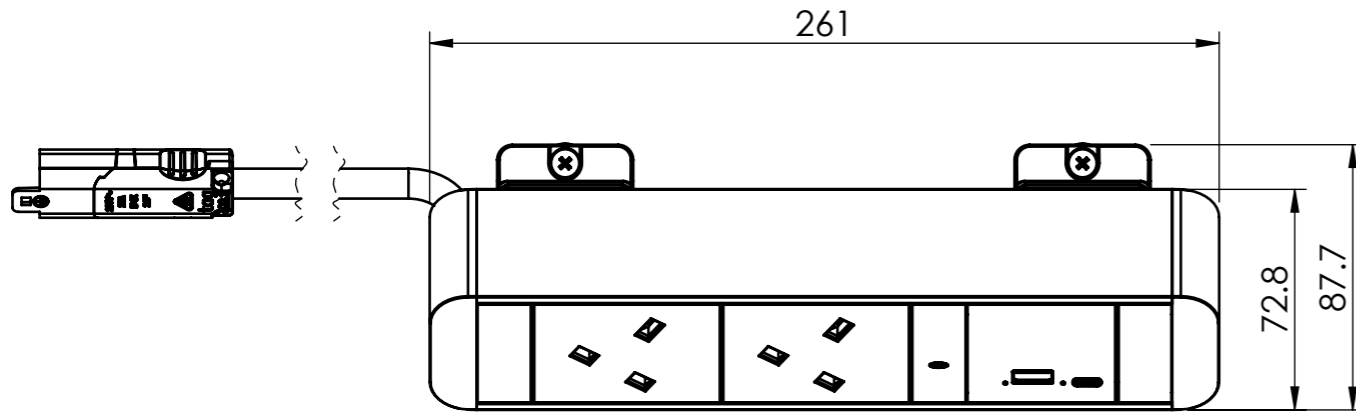

**PART NUMBER:** NKZN02UAC3xxXX

NOTE - xx - LENGTH - 05/10/15/20/25/30/35/40/45/50

XX - COLOUR - WT/BK/(BK/BK)/(WT/WT)/(WT/WM)

<b>CUSTOMER SIGNATURE:</b>		<b>TOLERANCES UNLESS OTHERWISE STATED:</b>		 <b>CMS Electracom</b> <small>COPYRIGHT © 2015</small>	
<b>MATERIAL:</b> PLASTIC / ALUMINIUM		X ±0.5 X.X ±0.2 X.XX ±0.1 X.XXX ±0.05 ANG ±0.5°			
<b>FINISH:</b> FINE EDM / ANODISED (POWDER COAT)		<b>COLOUR:</b> REFER TO TABLE		<b>TITLE:</b> ZEUS 2 WITH NK1802+NK18UAC3	
<b>REVISIONS</b>		THIS DRAWING & ASSOCIATED CAD FILES ARE ISSUED IN THE STRICTEST CONFIDENCE AND ARE ONLY TO BE USED IN THE COMMERCIAL INTERESTS OF CMS ELECTRACOM PTY LTD		<b>DRAWING:</b> LU44468	
1	RELEASED FOR PRODUCTION	14/11/2023	GC	AP	<b>REV:</b> 1 <b>A3</b>
REV	DESCRIPTION	DATE	DRWN	APPV	
		DRAWN IN mm TO AS1100 DO NOT SCALE		SCALE 2:5 SHEET 1 OF 2	

1	RELEASED FOR PRODUCTION	14/11/2023	GC	AP
REV	DESCRIPTION	DATE	DRWN	APPV
<b>REVISIONS</b>				