

30W USB AC MODUAL = U

USE SC_CMS131_11 WHEN INSTALLING USB

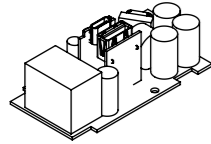

65W USB AC MODUAL = W

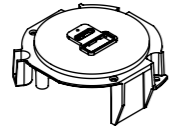
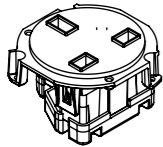

UK NON-FUSED OUTLET = C

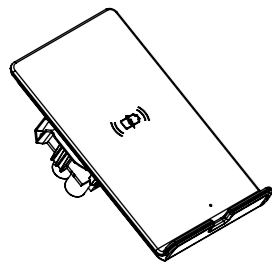

HELISTAND (15W) = P

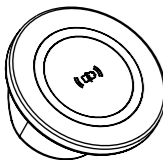

HELIPAD (15W) = J3
NON-QI2

**FACTORY ONLY INSERTABLE MODULES
REFER PAGE 2 FOR MODULE
CONFIGURATION**

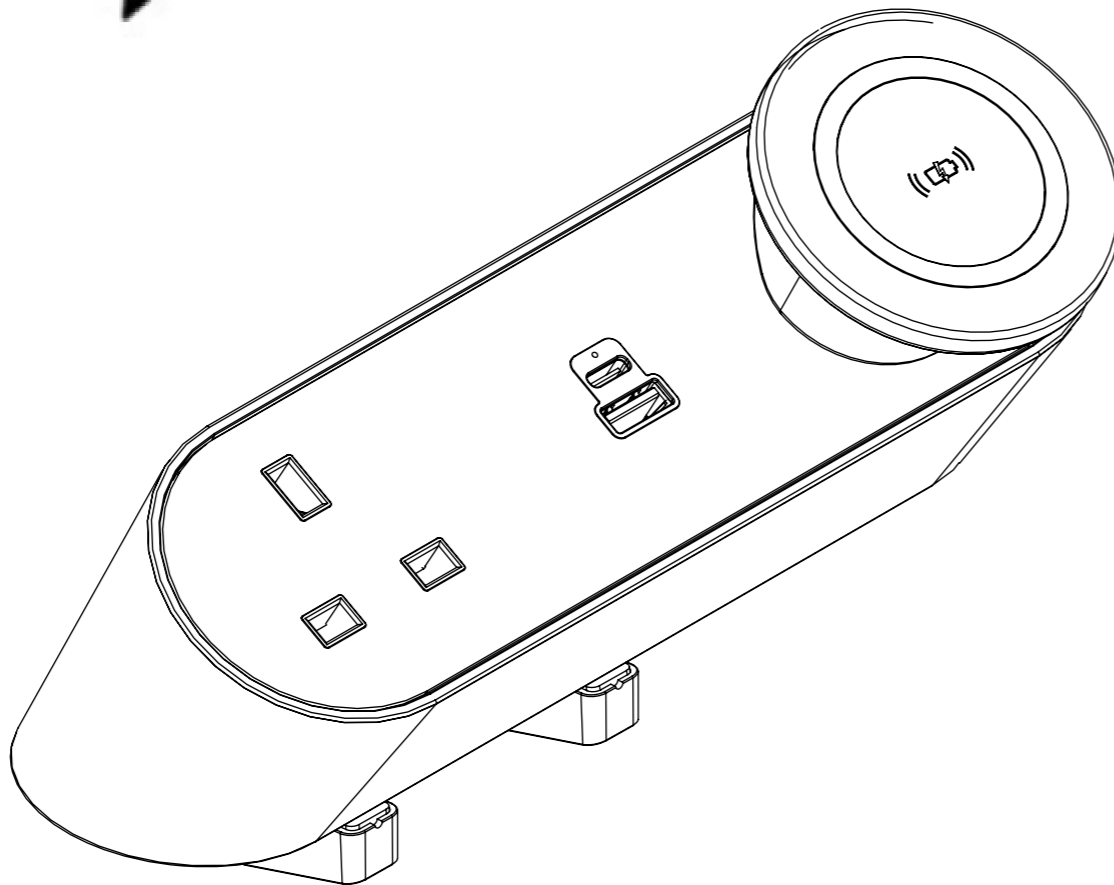

ABOVE DESK CLAMP

MIN TABLE THICKNESS: 20MM
MAX TABLE THICKNESS 32MM

NOTE:
TABLE SCALLOP OF **40MM MINIMUM
REQUIRED** WHEN USING HELISTAND &
PRIVACY SCREEN TO ALLOW ADDITIONAL
SPACE FOR LARGE PHONES

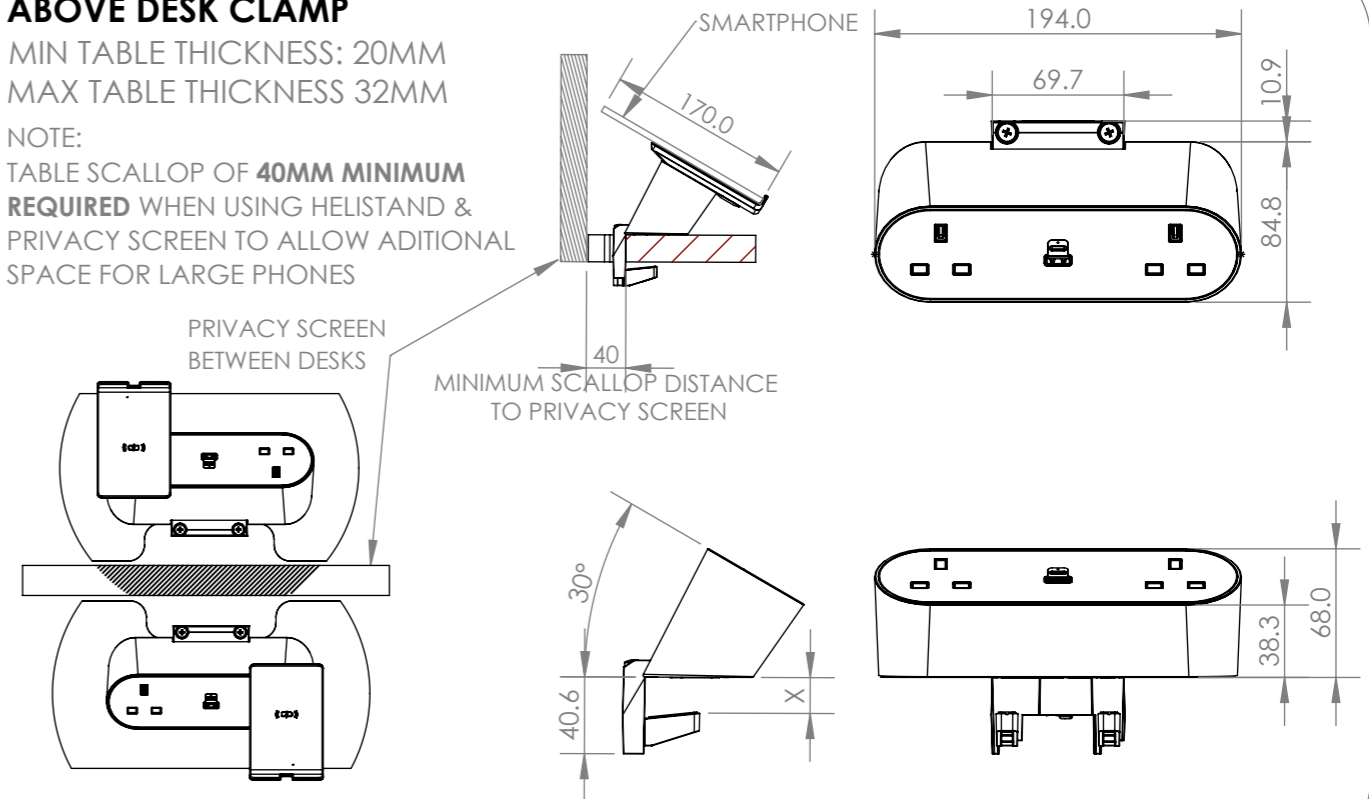

UNDER DESK CLAMP

COMPATIBLE MOUNTING
SCREWS: 4G, 6G

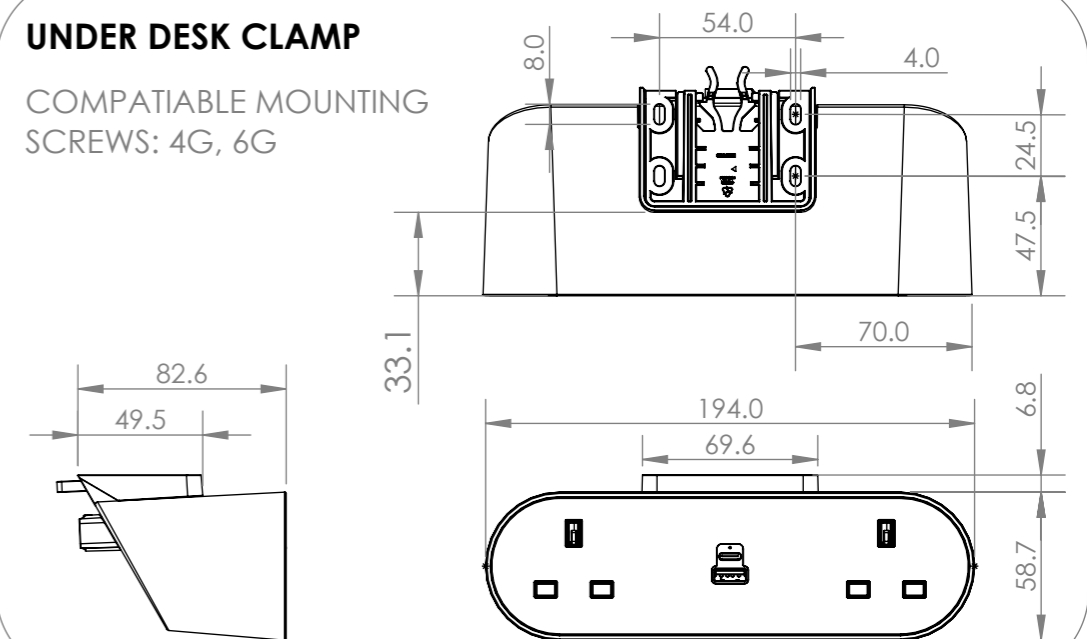

CUSTOMER
SIGNATURE:

MATERIAL: PC FR

FINISH: FINE EDM / POLISHED /
FABRIC

COLOUR: REFER TABLE

TOLERANCES UNLESS
OTHERWISE STATED:

X ±0.5
X.X ±0.2
X.XX ±0.1
X.XXX ±0.05
ANG ±0.5°



CMS Electracom COPYRIGHT
© 2020

TITLE: NOVA TRIO XL NON-QI2 UK NON-
FUSED CONFIGURATIONS

DRAWING:
LU48355

REV:
1 A3

THIS DRAWING & ASSOCIATED CAD FILES ARE
ISSUED IN THE STRICTEST CONFIDENCE AND
ARE ONLY TO BE USED IN THE COMMERCIAL
INTERESTS OF CMS ELECTRACOM PTY LTD

DRAWN IN mm
TO AS1100
DO NOT SCALE

SCALE 1:2

SHEET 1 OF 6

1	RELEASED FOR PRODUCTION	12/5/2025	JB	RG
REV	DESCRIPTION	DATE	DRWN	APPV
REVISIONS				

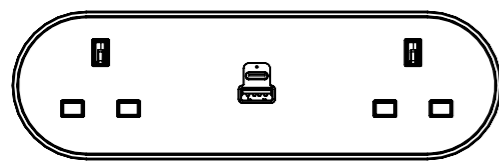

NT*CUCXxxXX

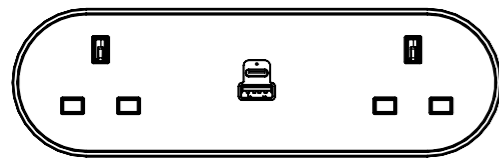

NT*CWCXxxXX

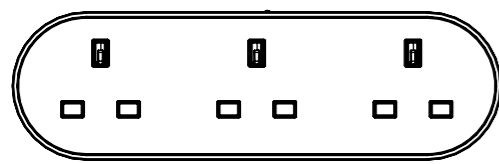

NT*CCCXxxXX

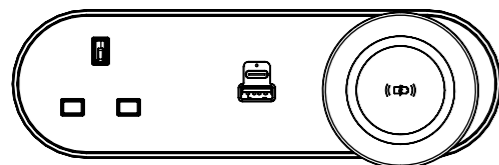

NT*CUJ3XxxXX

ABOVE DESK CLAMP ONLY

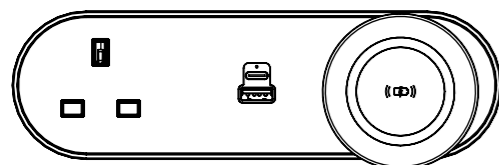

NT*CWJ3XxxXX

ABOVE DESK CLAMP ONLY

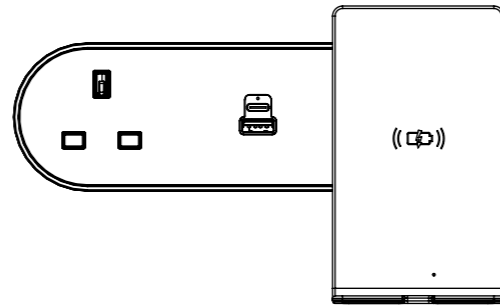

NT*CUPXxxXX
ABOVE DESK CLAMP ONLY

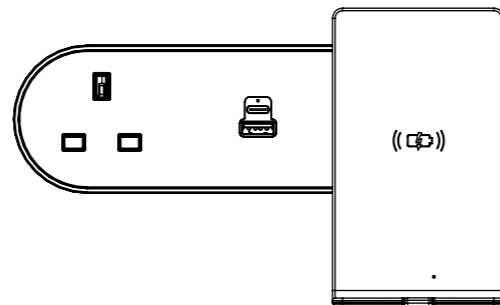

NT*CWPXxxXX
ABOVE DESK CLAMP ONLY

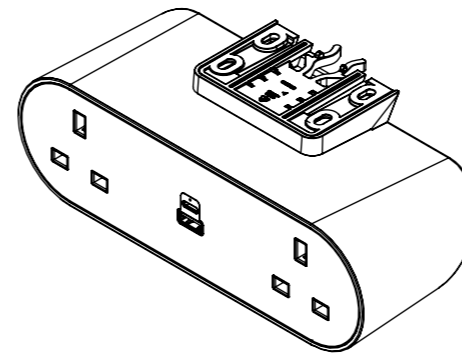

Z = UNDER DESK CLAMP

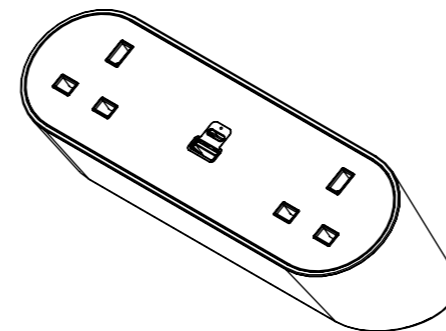

S= ABOVE DESK CLAMP

NOTE:

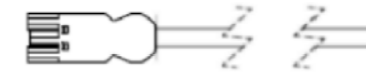

CABLE TYPE: 3 CORE x 1.5mm²
DESCRIPTION: GST PLUG LEAD
COLOUR: WHITE OR BLACK
(REFER TO PURCHASE ORDER)
LENGTH (mm):

xx	LENGTH (mm)
05	500
10	1000
15	1500
20	2000
25	2500
30	3000
35	3500
40	4000
45	4500
50	5000

NOTE:

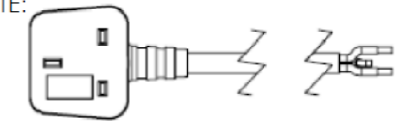

CABLE TYPE: 3 CORE x 1.5mm²
DESCRIPTION: BRITISH 13A PLUG LEAD
COLOUR: WHITE OR BLACK
(REFER TO PURCHASE ORDER)
LENGTH (mm):

xx	LENGTH (mm)
05	500
10	1000
15	1500
20	2000
25	2500
30	3000
35	3500
40	4000
45	4500
50	5000

NOTE:



CABLE TYPE: 3 CORE x 1.5mm²
DESCRIPTION: C-CONNECTOR LEAD
COLOUR: WHITE OR BLACK
(REFER TO PURCHASE ORDER)
LENGTH (mm):

xx	LENGTH (mm)
05	500
10	1000
15	1500
20	2000
25	2500
30	3000
35	3500
40	4000
45	4500
50	5000

PART NUMBER: (REFER CONFIGURATION)xxXX

NOTE - * - CLAMP TYPE - (S = ABOVE DESK OR Z = UNDER DESK)

X - LEAD TYPE (BS PLUG = B), (GST CONNECTOR = W), (C3.1 CONNECTOR = C)

xx - LENGTH - 05 / 10 / 15 / 20 / 25 / 30 / 35 / 40 / 45 / 50

XX - COLOUR - W / B + 1 / 2 / 3 / 4 + (OPTIONAL) A / B / C / D

COLOUR VARIATIONS	
PART NUMBER	DESCRIPTION
W	WHITE BODY & CLAMP
B	BLACK BODY & CLAMP
1	WHITE DECAL GLOSS
2	WHITE DECAL MATT
3	BLACK DECAL GLOSS
4	BLACK DECAL MATT
FABRIC FINISH REFER TO LU41142	
A	FABRIC COLOUR 1 - VANILA
B	FABRIC COLOUR 2 - SMOKE
C	FABRIC COLOUR 3 - IRON FORMERLY KNOWN AS CHARCOAL
D	FABRIC COLOUR 4 - CHARCOAL FORMERLY KNOWN AS BLACK

CUSTOMER SIGNATURE:	TOLERANCES UNLESS OTHERWISE STATED:
MATERIAL: PC FR	X ±0.5 X.X ±0.2 X.XX ±0.1 X.XXX ±0.05 ANG ±0.5°
FINISH: FINE EDM / POLISHED / FABRIC	
COLOUR: REFER TABLE	
THIS DRAWING & ASSOCIATED CAD FILES ARE ISSUED IN THE STRICTEST CONFIDENCE AND ARE ONLY TO BE USED IN THE COMMERCIAL INTERESTS OF CMS ELECTRACOM PTY LTD	DRAWN IN mm TO AS1100 DO NOT SCALE



TITLE: NOVA TRIO XL NON-QI2 UK NON-FUSED CONFIGURATIONS	
DRAWING: LU48355	REV: 1
SCALE 1:2	SHEET 2 OF 6

A3