

30W USB AC MODUAL = U

USE SC\_CMS131\_11 WHEN INSTALLING USB

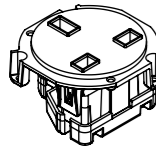

UK NON-FUSED OUTLET = C

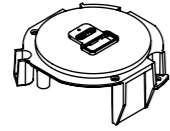
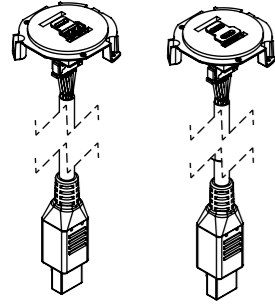

100W USB: A+C = V OR C+C = K  
118W USB: A+C = Q OR C+C = M  
140W USB: A+C = Y OR C+C = S

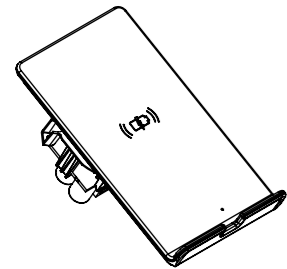

HLISTAND (15W) = P

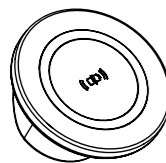

HELIPAD (15W) = J3  
NON-QI2

**FACTORY ONLY INSERTABLE MODULES  
REFER PAGE 2 FOR MODULE  
CONFIGURATION**

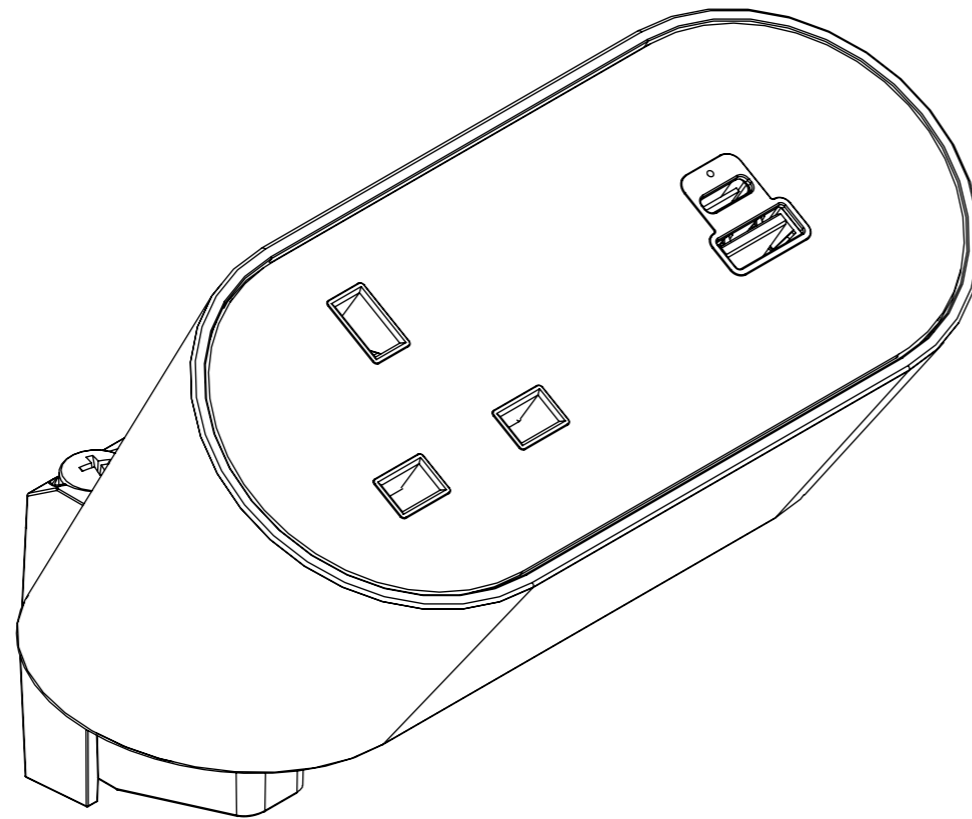

**ABOVE DESK CLAMP**

MIN TABLE THICKNESS: 20MM  
MAX TABLE THICKNESS 32MM

NOTE:  
TABLE SCALLOP OF **40mm MINIMUM  
REQUIRED** WHEN USING HELISTAND &  
PRIVACY SCREEN TO ALLOS  
ADDITIONAL SPACE FOR LARG  
PHONES

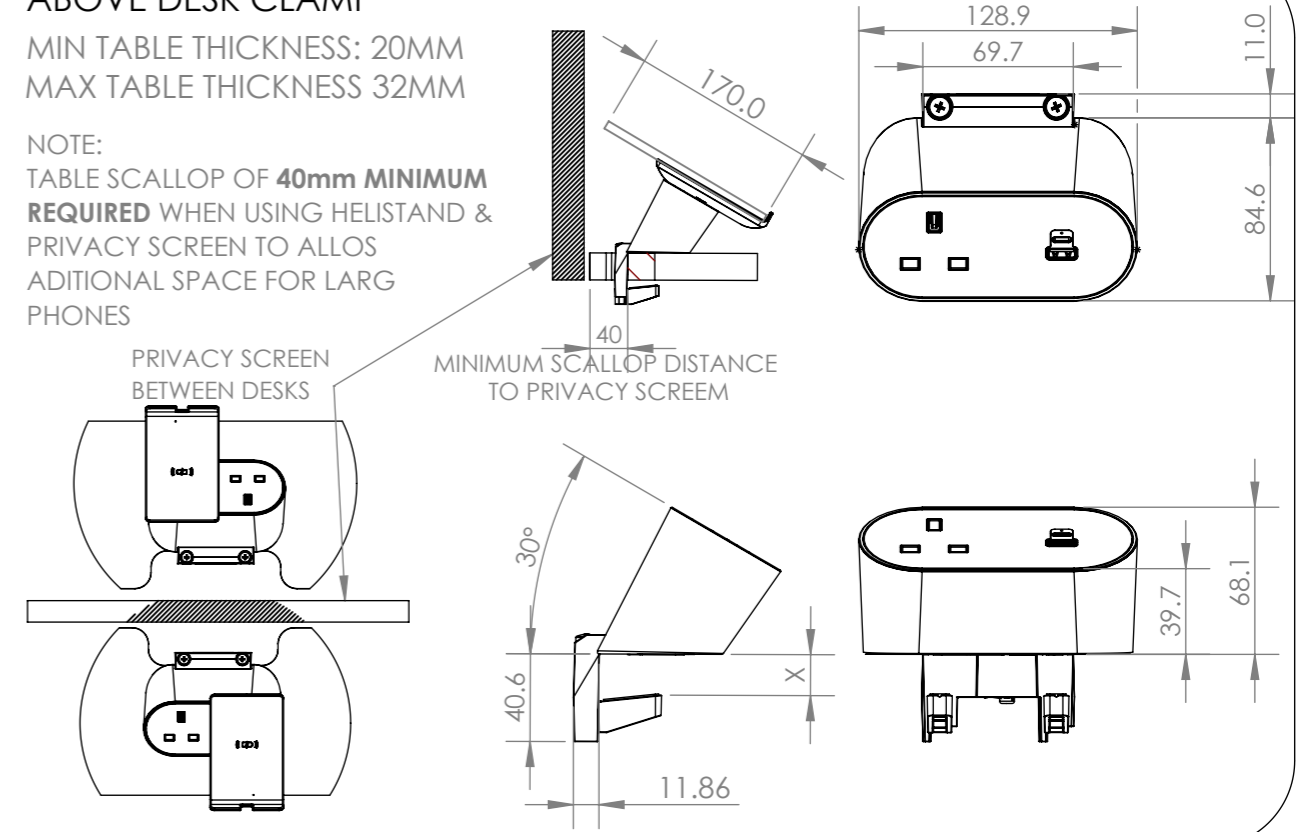

**UNDER DESK CLAMP**

COMPATIBLE MOUNTING  
SCREWS: 4G, 6G

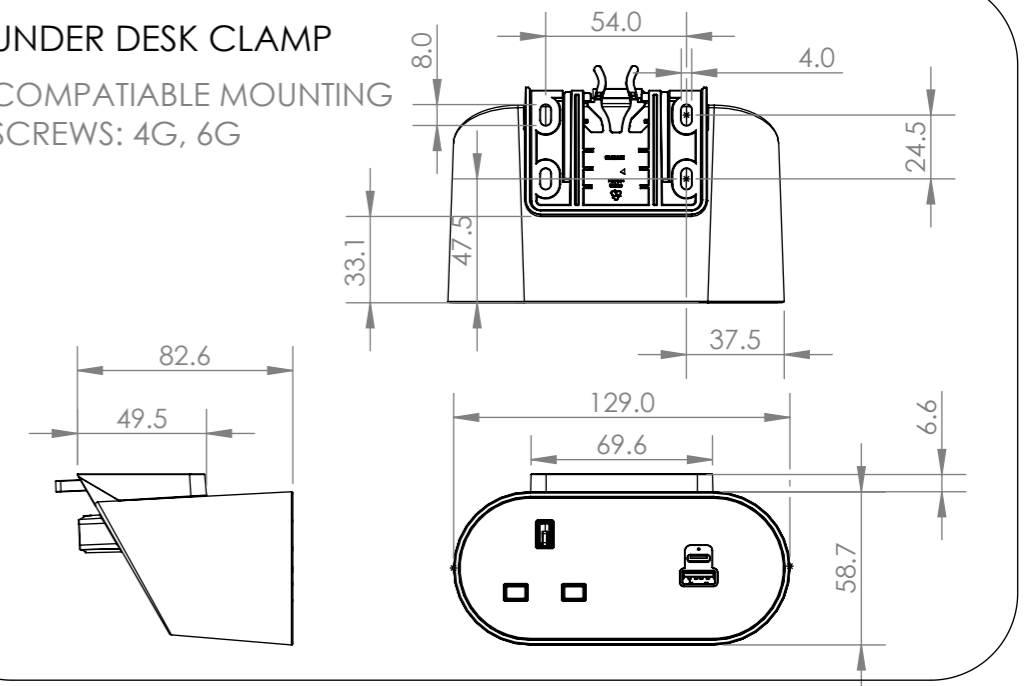

<b>CUSTOMER SIGNATURE:</b>		<b>TOLERANCES UNLESS OTHERWISE STATED:</b>  X ±0.5 X.X ±0.2 X.XX ±0.1 X.XXX ±0.05 ANG ±0.5°
<b>MATERIAL:</b>	PC FR	
<b>FINISH:</b>	FINE EDM / POLISHED / FABRIC	
<b>COLOUR:</b>	REFER TABLE	
THIS DRAWING & ASSOCIATED CAD FILES ARE ISSUED IN THE STRICTEST CONFIDENCE AND ARE ONLY TO BE USED IN THE COMMERCIAL INTERESTS OF CMS ELECTRACOM PTY LTD		DRAWN IN mm TO AS1100 DO NOT SCALE



**TITLE:**  
NOVA DUO XL NON-QI2 UK NON-FUSED CONFIGURATIONS

<b>DRAWING:</b> LU48373	<b>REV:</b> 1	<b>A3</b>
SCALE 1:2	SHEET 1 OF 10	

1	RELEASED FOR PRODUCTION	19/5/2025	JB	RG
REV	DESCRIPTION	DATE	DRWN	APPV
REVISIONS				

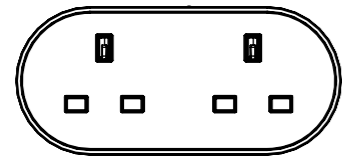

ND\*CCXxxXX

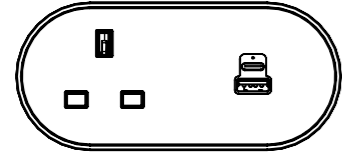

ND\*CUXxxXX

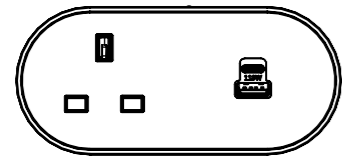

ND\*C1XxxXX  
ONLY AVAILABLE IN ABOVE DESK CLAMP

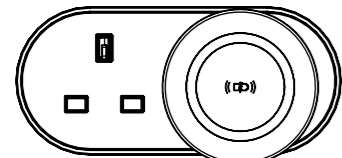

ND\*CJ3XxxXX  
ONLY AVAILABLE IN ABOVE DESK CLAMP

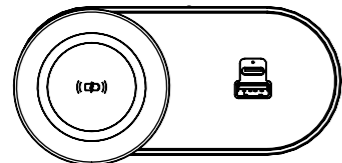

ND\*J3UXxxXX  
ONLY AVAILABLE IN ABOVE DESK CLAMP

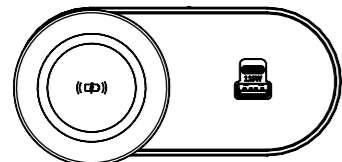

ND\*J31XxxXX  
ONLY AVAILABLE IN ABOVE DESK CLAMP

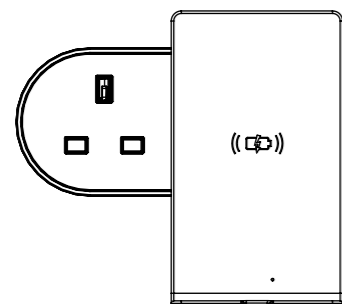

ND\*CPXxxXX  
ONLY AVAILABLE IN ABOVE DESK CLAMP

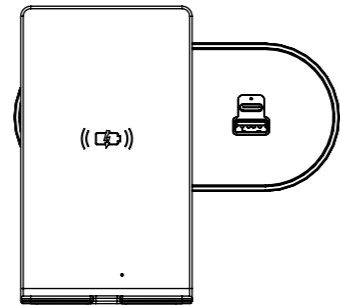

ND\*PUXxxXX  
ONLY AVAILABLE IN ABOVE DESK CLAMP

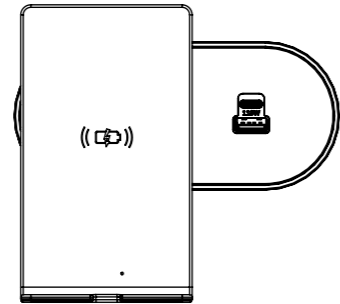

ND\*P1XxxXX  
ONLY AVAILABLE IN ABOVE DESK CLAMP

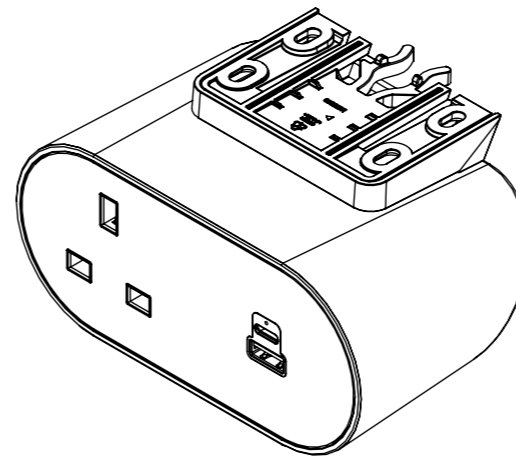

Z = UNDER DESK CLAMP

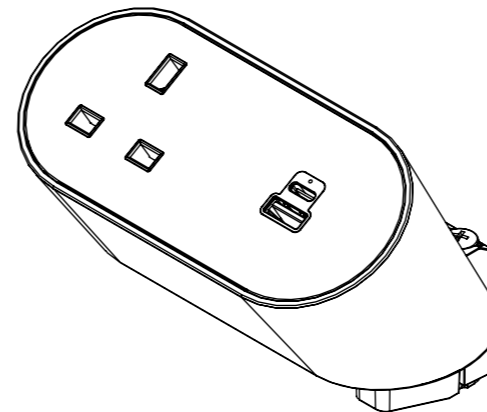

S = ABOVE DESK CLAMP

NOTE:

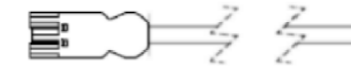

CABLE TYPE: 3 CORE x 1.5mm<sup>2</sup>  
DESCRIPTION: GST PLUG LEAD  
COLOUR: WHITE OR BLACK  
(REFER TO PURCHASE ORDER)  
LENGTH (mm):

xx	LENGTH (mm)
05	500
10	1000
15	1500
20	2000
25	2500
30	3000
35	3500
40	4000
45	4500
50	5000

NOTE:

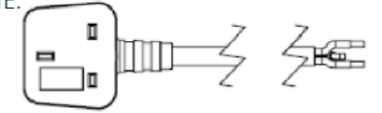

CABLE TYPE: 3 CORE x 1.5mm<sup>2</sup>  
DESCRIPTION: BRITISH 13A PLUG LEAD  
COLOUR: WHITE OR BLACK  
(REFER TO PURCHASE ORDER)  
LENGTH (mm):

xx	LENGTH (mm)
05	500
10	1000
15	1500
20	2000
25	2500
30	3000
35	3500
40	4000
45	4500
50	5000

NOTE:



CABLE TYPE: 3 CORE x 1.5mm<sup>2</sup>  
DESCRIPTION: C-CONNECTOR LEAD  
COLOUR: WHITE OR BLACK  
(REFER TO PURCHASE ORDER)  
LENGTH (mm):

xx	LENGTH (mm)
05	500
10	1000
15	1500
20	2000
25	2500
30	3000
35	3500
40	4000
45	4500
50	5000

**PART NUMBER:** (REFER CONFIGURATION)xxXX

NOTE - \* - CLAMP TYPE - (S = ABOVE DESK OR Z = UNDER DESK)

1 - USB (V = 100W USB A+C, K = C+C OR Q = 118W USB A+C, M = C+C OR Y = 140W USB A+C, S = C+C)

X - LEAD TYPE (BS PLUG = B), (GST CONNECTOR = W), (C3.1 CONNECTOR = C)

xx - LENGTH - 05 / 10 / 15 / 20 / 25 / 30 / 35 / 40 / 45 / 50

XX - COLOUR - W / B + 1 / 2 / 3 / 4 + (OPTIONAL) A / B / C / D

COLOUR VARIATIONS	
PART NUMBER	DESCRIPTION
W	WHITE BODY & CLAMP
B	BLACK BODY & CLAMP
1	WHITE DECAL GLOSS
2	WHITE DECAL MATT
3	BLACK DECAL GLOSS
4	BLACK DECAL MATT
FABRIC FINISH REFER TO LU41144	
A	FABRIC COLOUR 1 - VANILA
B	FABRIC COLOUR 2 - SMOKE
C	FABRIC COLOUR 3 - IRON FORMERLY KNOWN AS CHARCOAL
D	FABRIC COLOUR 4 - CHARCOAL FORMERLY KNOWN AS BLACK

<b>CUSTOMER SIGNATURE:</b>	<b>TOLERANCES UNLESS OTHERWISE STATED:</b>
<b>MATERIAL:</b> PC FR	X ±0.5 X.X ±0.2 X.XX ±0.1 X.XXX ±0.05 ANG ±0.5°
<b>FINISH:</b> FINE EDM / POLISHED / FABRIC	
<b>COLOUR:</b> REFER TABLE	
THIS DRAWING & ASSOCIATED CAD FILES ARE ISSUED IN THE STRICTEST CONFIDENCE AND ARE ONLY TO BE USED IN THE COMMERCIAL INTERESTS OF CMS ELECTRACOM PTY LTD	DRAWN IN mm TO AS1100 DO NOT SCALE

 **CMS Electracom** COPYRIGHT © 2020

**TITLE:**  
NOVA DUO XL NON-Q12 UK NON-FUSED CONFIGURATIONS

**DRAWING:** LU48373 **REV:** 1 **A3**

SCALE 1:2 SHEET 2 OF 10