

30W USB AC MODUAL = U

USE SC\_CMS131\_11 WHEN INSTALLING USB

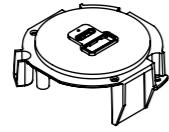

UK NON-FUSED OUTLET = C

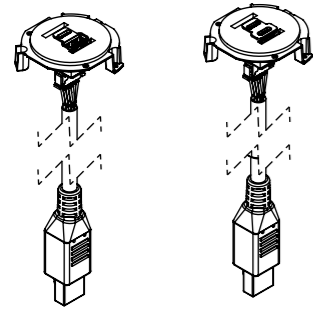

100W USB: A+C = V OR C+C = K  
118W USB: A+C = Q OR C+C = M  
140W USB: A+C = 7 OR C+C = S

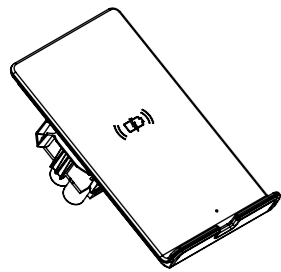

HELISTAND (15W) = P

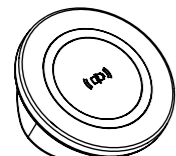

HELIPAD (15W) = J3  
NON-QI2

**FACTORY ONLY INSERTABLE MODULES  
REFER PAGE 2 FOR MODULE  
CONFIGURATION**

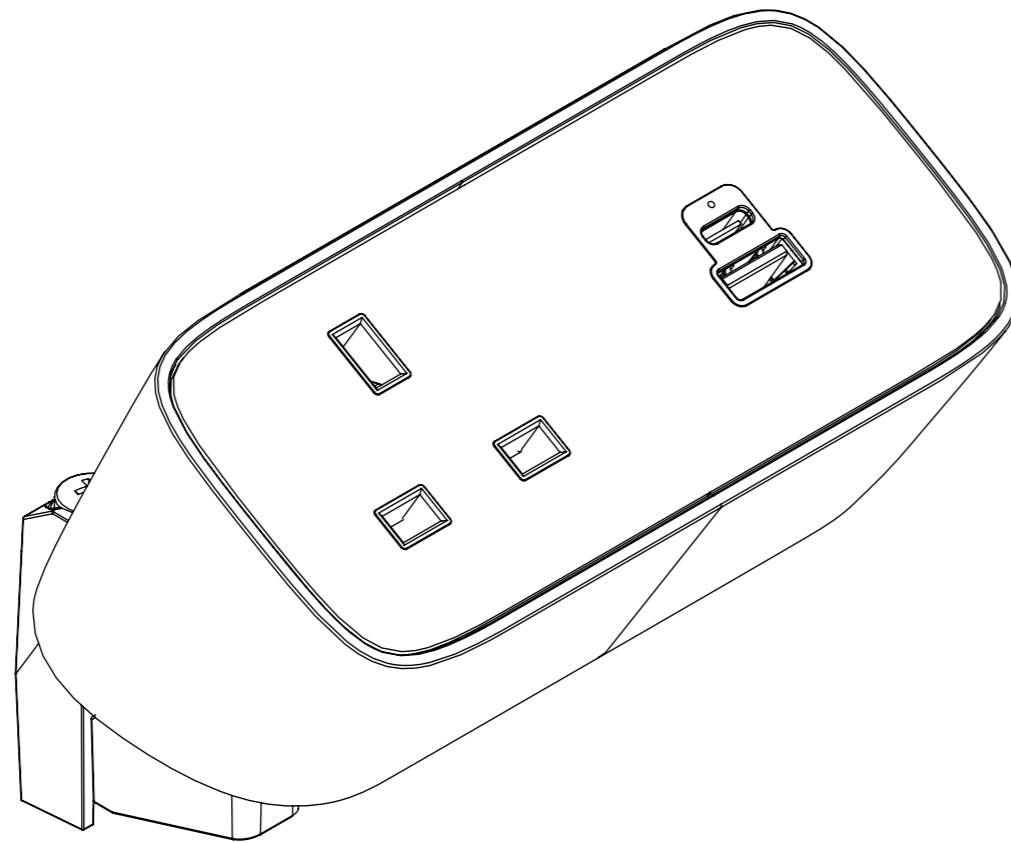

**ABOVE DESK CLAMP**

MIN TABLE THICKNESS: 20MM  
MAX TABLE THICKNESS 32MM

NOTE:  
TABLE SCALLOP OF **40mm MINIMUM REQUIRED** WHEN USING HELISTAND & PRIVACY SCREEN TO ALLOW ADDITIONAL SPACE FOR LARGE PHONES

PRIVACY SCREEN BETWEEN DESKS

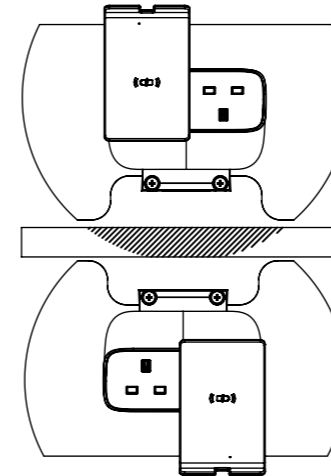

40  
MINIMUM SCALLOP DISTANCE TO PRIVACY SCREEN

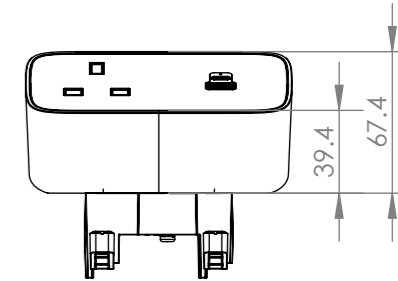
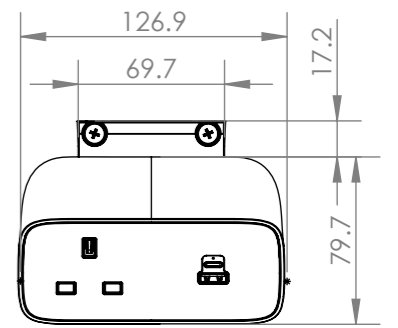
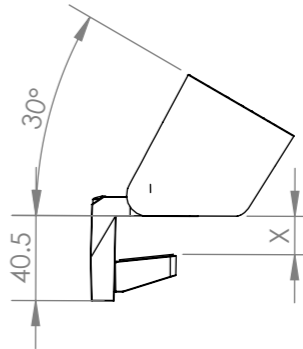
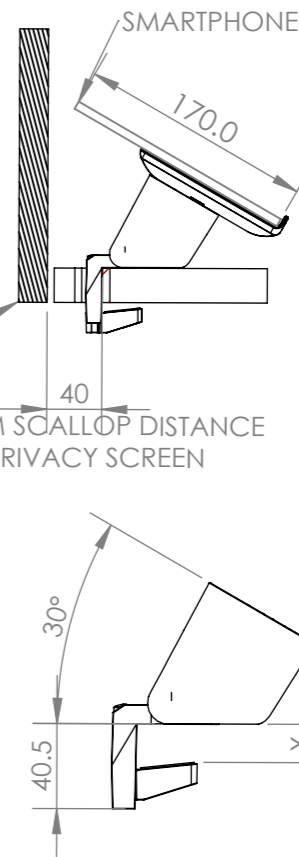

**UNDER DESK CLAMP  
COMPATIBLE MOUNTING  
SCREWS: 4G, 6G**

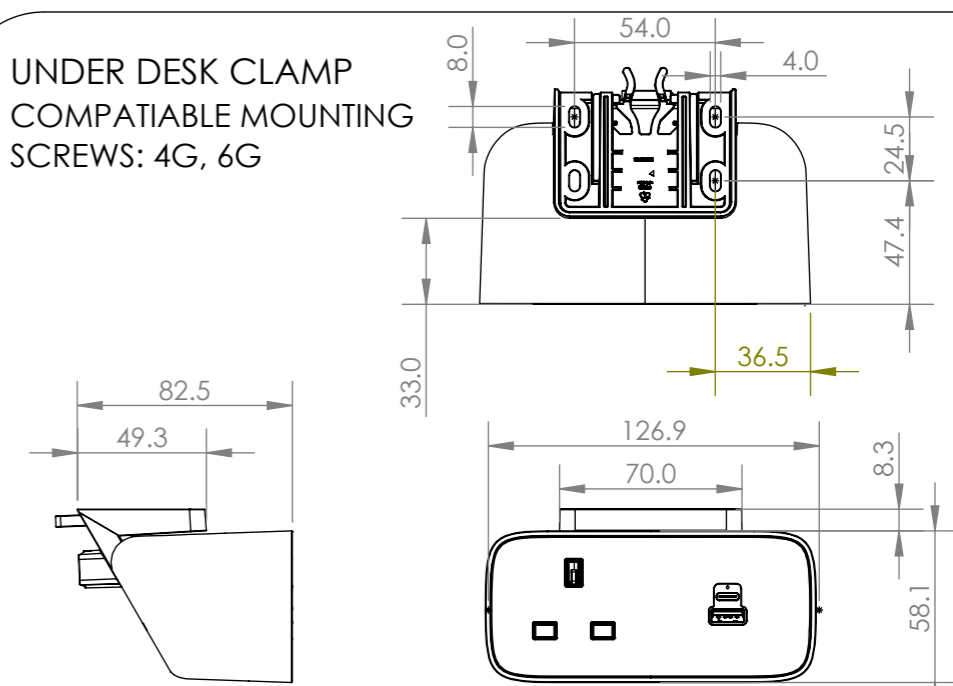

CUSTOMER SIGNATURE:

MATERIAL: PC FR

FINISH: FINE EDM / POLISHED / FABRIC

COLOUR: REFER TABLE

TOLERANCES UNLESS OTHERWISE STATED:

X ±0.5  
X.X ±0.2  
X.XX ±0.1  
X.XXX ±0.05  
ANG ±0.5°



**CMS Electracom**

COPYRIGHT © 2020

TITLE: **VIVA DUO XL NON-QI2 UK NON-FUSED CONFIGURATIONS**

DRAWING: **LU48471**

REV: **1**  
**A3**

1	RELEASED FOR PRODUCTION	23/5/2025	JB	RG
REV	DESCRIPTION	DATE	DRWN	APPV
REVISIONS				

THIS DRAWING & ASSOCIATED CAD FILES ARE ISSUED IN THE STRICTEST CONFIDENCE AND ARE ONLY TO BE USED IN THE COMMERCIAL INTERESTS OF CMS ELECTRACOM PTY LTD

DRAWN IN mm TO AS1100 DO NOT SCALE

SCALE 1:2

SHEET 1 OF 9

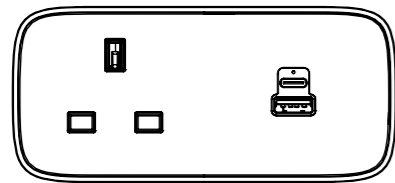

VD\*CUXxxXX

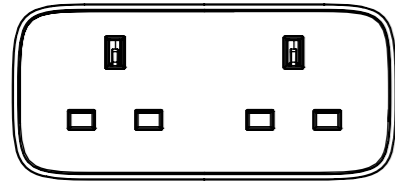

VD\*CCXxxXX

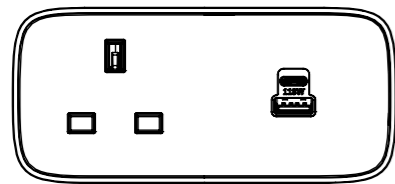

VD\*C1XxxXX  
ONLY AVAILABLE IN ABOVE  
DESK CLAMP

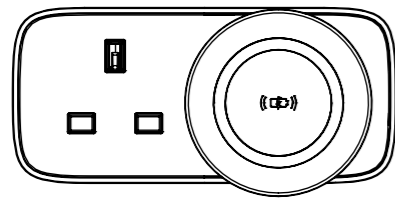

VD\*CJ3XxxXX  
ONLY AVAILABLE IN ABOVE  
DESK CLAMP

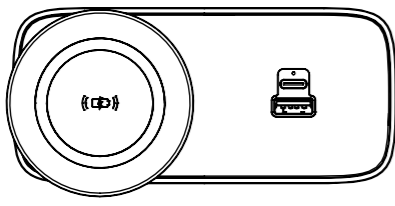

VD\*J3UXxxXX  
ONLY AVAILABLE IN ABOVE  
DESK CLAMP

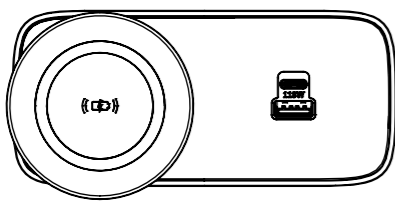

VD\*J31XxxXX  
ONLY AVAILABLE IN ABOVE  
DESK CLAMP

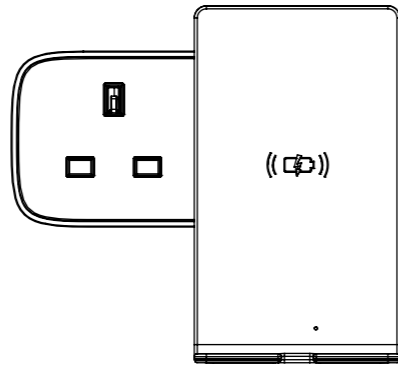

VD\*CPXxxXX  
ONLY AVAILABLE IN ABOVE  
DESK CLAMP

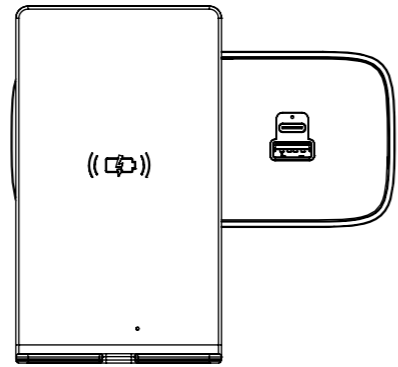

VD\*PUXxxXX  
ONLY AVAILABLE IN ABOVE  
DESK CLAMP

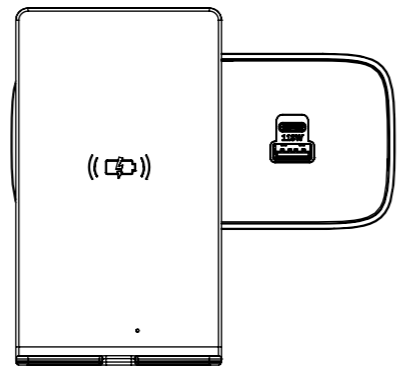

VD\*P1XxxXX  
ONLY AVAILABLE IN ABOVE  
DESK CLAMP

**PART NUMBER:** (REFER CONFIGURATION)xxXX

NOTE - \* - CLAMP TYPE - (S = ABOVE DESK OR Z = UNDER DESK)

1 - USB (V = 100W SUB A+C, K = C+C OR Q = 118 USB A+C, M = C+C OR Y = 140W USB A+C, S = C+C)

X - LEAD TYPE (BS PLUG = B), (GST CONNECTOR = W), (C3.1 CONNECTOR = C)

xx - LENGTH - 05 / 10 / 15 / 20 / 25 / 30 / 35 / 40 / 45 / 50

XX - COLOUR - W / B + 1 / 2 / 3 / 4 + (OPTIONAL) A / B / C / D

NOTE:



CABLE TYPE: 3 CORE x 1.5mm<sup>2</sup>  
DESCRIPTION: GST PLUG LEAD  
COLOUR: WHITE OR BLACK  
(REFER TO PURCHASE ORDER)  
LENGTH (mm):

xx	LENGTH (mm)
05	500
10	1000
15	1500
20	2000
25	2500
30	3000
35	3500
40	4000
45	4500
50	5000

NOTE:

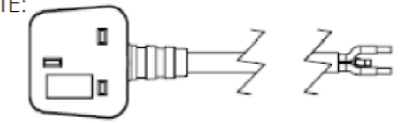

CABLE TYPE: 3 CORE x 1.5mm<sup>2</sup>  
DESCRIPTION: BRITISH 13A PLUG LEAD  
COLOUR: WHITE OR BLACK  
(REFER TO PURCHASE ORDER)  
LENGTH (mm):

xx	LENGTH (mm)
05	500
10	1000
15	1500
20	2000
25	2500
30	3000
35	3500
40	4000
45	4500
50	5000

NOTE:

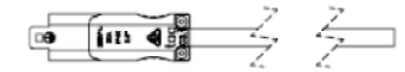

CABLE TYPE: 3 CORE x 1.5mm<sup>2</sup>  
DESCRIPTION: C-CONNECTOR LEAD  
COLOUR: WHITE OR BLACK  
(REFER TO PURCHASE ORDER)  
LENGTH (mm):

xx	LENGTH (mm)
05	500
10	1000
15	1500
20	2000
25	2500
30	3000
35	3500
40	4000
45	4500
50	5000

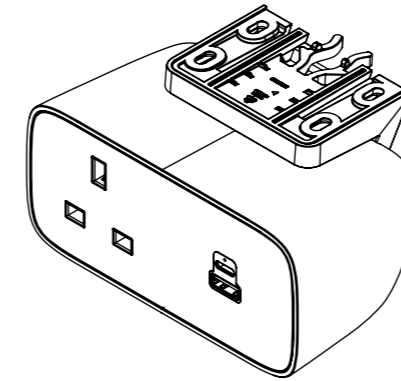

Z = UNDER DESK CLAMP

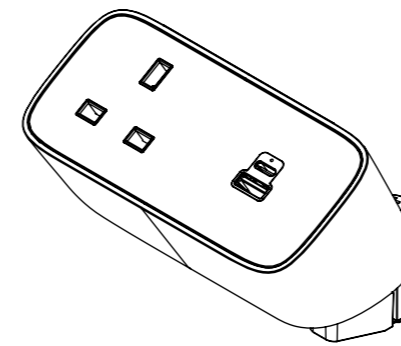

S = ABOVE DESK CLAMP

COLOUR VARIATIONS	
PART NUMBER	DESCRIPTION
W	WHITE BODY & CLAMP
B	BLACK BODY & CLAMP
1	WHITE DECAL GLOSS
2	WHITE DECAL MATT
3	BLACK DECAL GLOSS
4	BLACK DECAL MATT
FABRIC FINISH REFER TO LU41144	
A	FABRIC COLOUR 1 - VANILA
B	FABRIC COLOUR 2 - SMOKE
C	FABRIC COLOUR 3 - IRON FORMERLY KNOWN AS CHARCOAL
D	FABRIC COLOUR 4 - CHARCOAL FORMERLY KNOWN AS BLACK

<b>CUSTOMER SIGNATURE:</b>	<b>TOLERANCES UNLESS OTHERWISE STATED:</b>
<b>MATERIAL:</b> PC FR	X ±0.5 X.X ±0.2 X.XX ±0.1 X.XXX ±0.05 ANG ±0.5°
<b>FINISH:</b> FINE EDM / POLISHED / FABRIC	
<b>COLOUR:</b> REFER TABLE	
THIS DRAWING & ASSOCIATED CAD FILES ARE ISSUED IN THE STRICTEST CONFIDENCE AND ARE ONLY TO BE USED IN THE COMMERCIAL INTERESTS OF CMS ELECTRACOM PTY LTD	DRAWN IN mm TO AS1100 DO NOT SCALE



**TITLE:**  
VIVA DUO XL NON-QI2 UK NON-FUSED CONFIGURATIONS

**DRAWING:**  
LU48471

**REV:**  
1 A3

SCALE 1:2 SHEET 2 OF 9