

## VERO

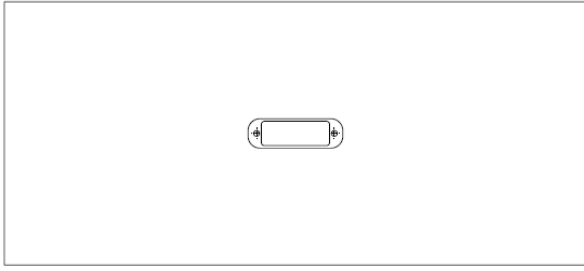

PRECISION MACHINE CUTOUT INTO DESK OR JOINERY AS PER THE SIZE/TOLERANCE LISTED ON THE TECHNICAL DRAWING OF THE MODEL SELECTED

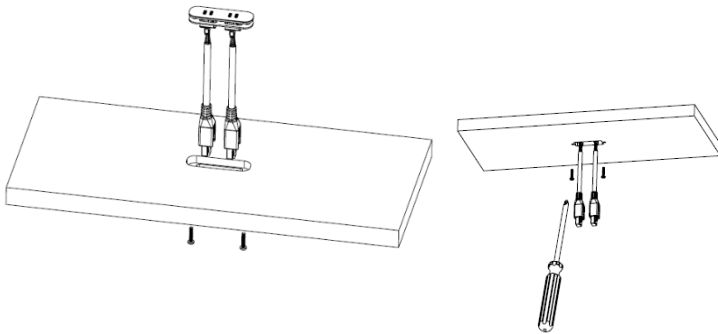

INSTALLING THE USB UNIT INTO THE CUTOUT-INSTALL USB CABLES INTO THE KEYSTONE JACKS  
*(NOTING THE CORRECT ALIGNMENT OF THE CONNECTIONS)*

INSERT UNIT INTO THE CUTOUT AND SECURE THE UNIT FROM BELOW USING THE SCREWS PROVIDED  
*(DO NOT OVER TIGHTEN)*

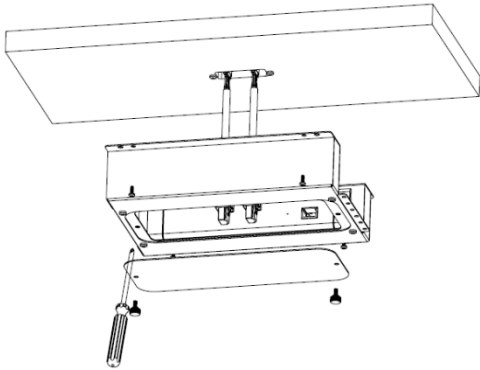

INSTALL THE POWER UNDERCARRIAGE EQUALLY DISTANCE AROUND THE USB UNIT CUTOUT USING THE CORRECT LENGTH SELF TAPPING SCREWS

REMOVING THE ACCESS HATCH ALLOWS ACCESSIBILITY TO PLUG IN THE USB LEADS INTO THE USB CHARGER PORTS

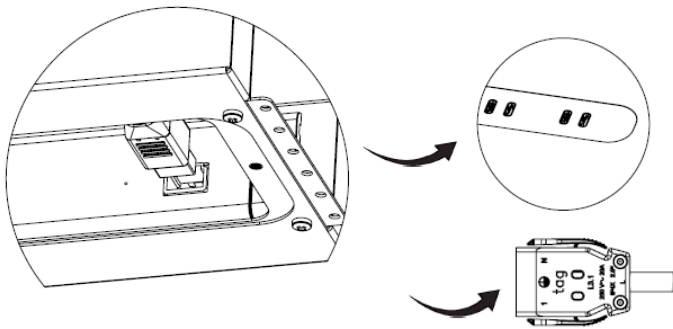

PLUG IN 12-PIN CONNECTOR TO KEYSTONE USB MODULE

REPLACE THE ACCESS HATCH

CONNECT THE TAG CONNECTOR TO SOFTWIRING LEADS OR STARTER LEAD TO POWER THE UNIT