

30W USB AC MODUAL = U

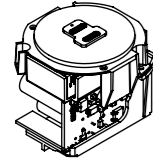

65W USB CC MODUAL = W2

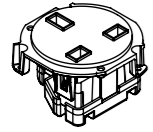

UK NON-FUSED OUTLET = C

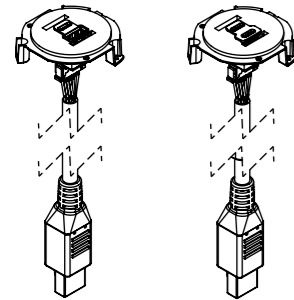

100W USB: A+C = V OR C+C = K  
118W USB: A+C = Q OR C+C = M  
140W USB: A+C = Y OR C+C = S

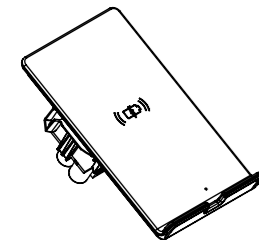

HLISTAND (15W) WIRELESS CHARGER = P

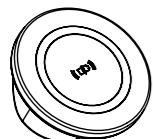

HELIPAD (15W) MAGNETIC WIRELESS CHARGER = J3

**FACTORY ONLY INSERTABLE MODULES  
REFER PAGE 2 FOR MODULE  
CONFIGURATION**

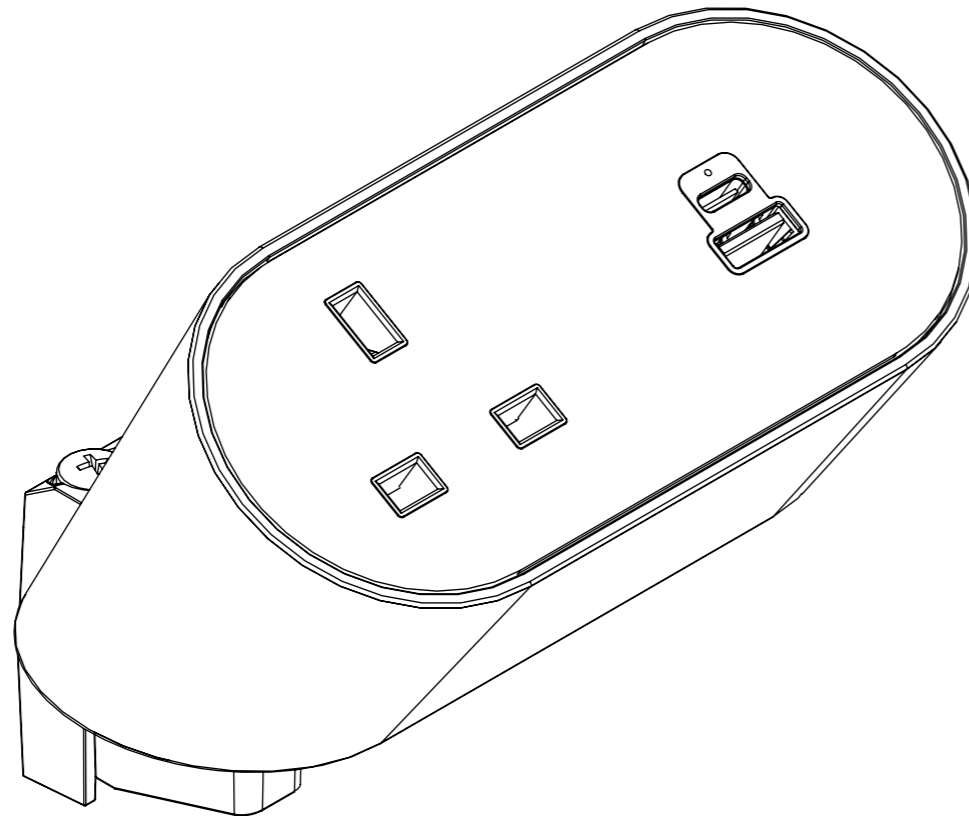

**ABOVE DESK CLAMP**

MIN TABLE THICKNESS: 20MM  
MAX TABLE THICKNESS 32MM

NOTE:  
TABLE SCALLOP OF **40mm MINIMUM REQUIRED** WHEN USING HELISTAND & PRIVACY SCREEN TO ALLOS  
ADDITIONAL SPACE FOR LARG  
PHONES

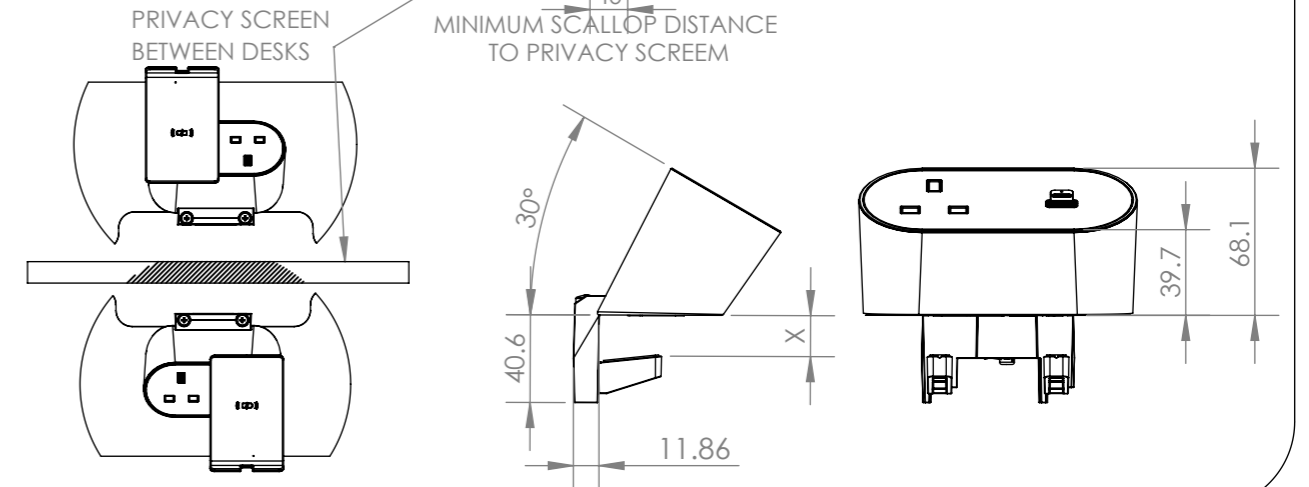

**UNDER DESK CLAMP**

COMPATIBLE MOUNTING  
SCREWS: 4G, 6G

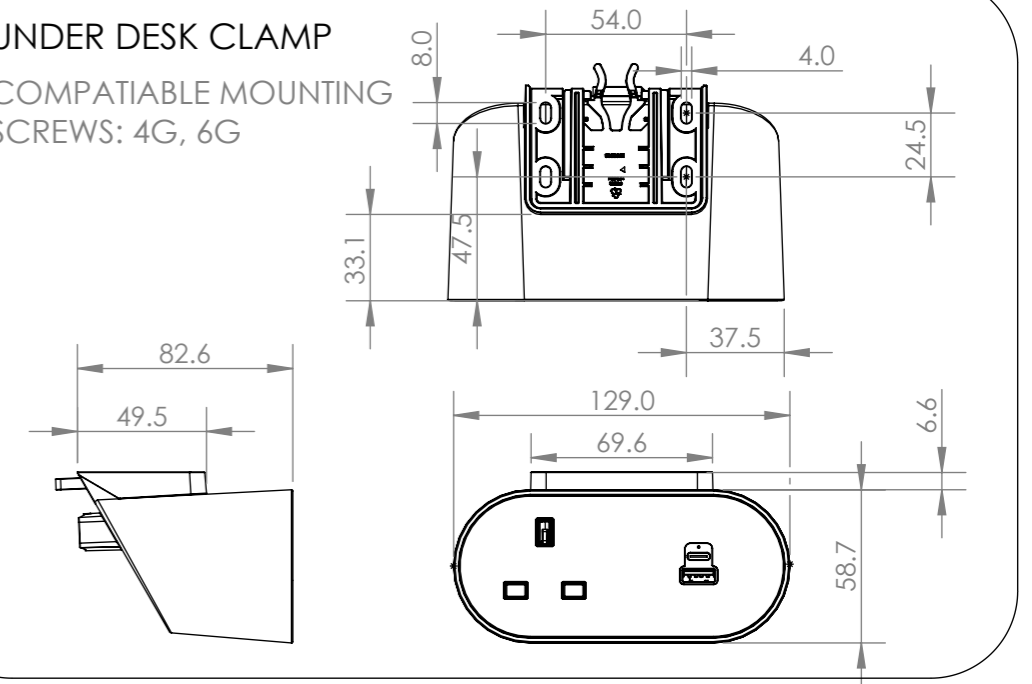

REV	DESCRIPTION	DATE	DRWN	APPV
7	"B" CORRECTED TO "G" FOR PLUG LEAD NOTE	18/3/2026	JB	RG
6	65W USB CC CONFIGURATIONS ADDED. DRAWING FORMAT UPDATED	20/10/2025	JB	RG
5	DRAWING FORMAT UPDATED. MAGNETIC WIRELESS CHARGER CONFIGURATIONS ADDED. NEW BOM'S ADDED	18/8/2025	JB	RG
4	NEW CONFIGURATIONS ADDED	12/1/2024	JB	RG
3	COLOUR TABLE UPDATED	31/10/2023	JB	RG
2	SCREW NOTE ADDED FOR USE OF TYPE 25 OR TYPE B	28/7/2022	JB	RG
1	RELEASED FOR PRODUCTION	21/6/2022	JB	RG
REVISIONS				

<b>CUSTOMER SIGNATURE:</b>	
<b>MATERIAL:</b>	PC FR
<b>FINISH:</b>	FINE EDM / POLISHED / FABRIC
<b>COLOUR:</b>	REFER TABLE
THIS DRAWING & ASSOCIATED CAD FILES ARE ISSUED IN THE STRICTEST CONFIDENCE AND ARE ONLY TO BE USED IN THE COMMERCIAL INTERESTS OF CMS ELECTRACOM PTY LTD	

**TOLERANCES UNLESS OTHERWISE STATED:**

X ±0.5  
X.X ±0.2  
X.XX ±0.1  
X.XXX ±0.05  
ANG ±0.5°

DRAWN IN mm TO AS1100 DO NOT SCALE

**CMS Electracom** COPYRIGHT © 2020

**TITLE:** NOVA DUO XL UK NON-FUSED CONFIGURATIONS

**DRAWING:** LU39644 **REV:** 7 **A3**

SCALE 1:2 SHEET 1 OF 14

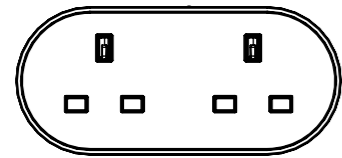

ND\*CCXxxXX

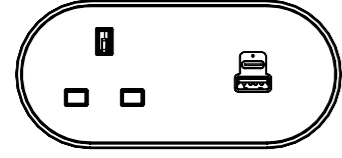

ND\*CUXxxXX

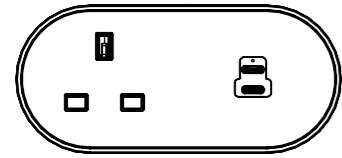

ND\*CW2XxxXX

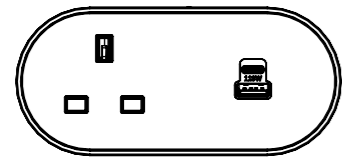

ND\*C1XxxXX  
ONLY AVAILABLE IN ABOVE  
DESK CLAMP

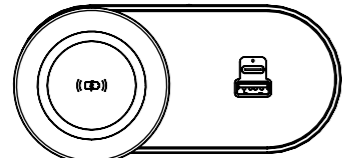

ND\*J3UXxxXX  
ONLY AVAILABLE IN ABOVE  
DESK CLAMP

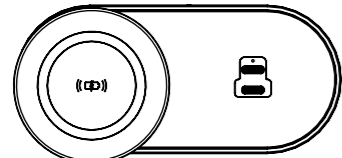

ND\*J3W2XxxXX  
ONLY AVAILABLE IN ABOVE  
DESK CLAMP

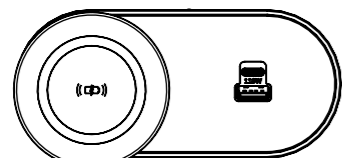

ND\*J31XxxXX  
ONLY AVAILABLE IN ABOVE  
DESK CLAMP

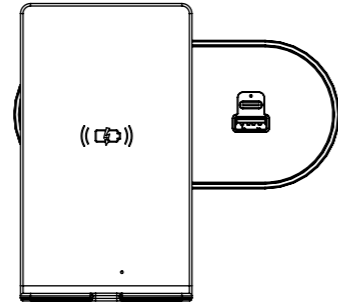

ND\*PUXxxXX  
ONLY AVAILABLE IN ABOVE  
DESK CLAMP

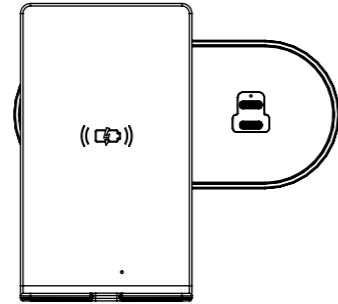

ND\*PW2XxxXX  
ONLY AVAILABLE IN ABOVE  
DESK CLAMP

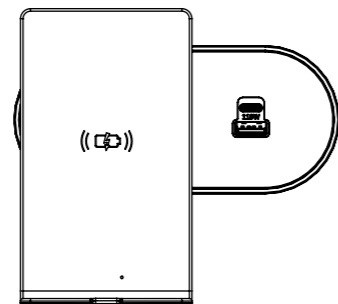

ND\*P1XxxXX  
ONLY AVAILABLE IN ABOVE  
DESK CLAMP

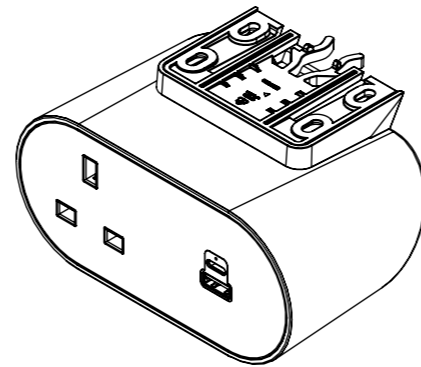

Z = UNDER DESK CLAMP

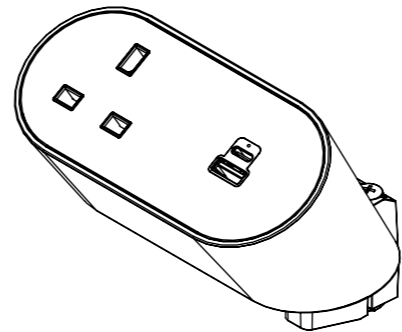

S = ABOVE DESK CLAMP

NOTE:

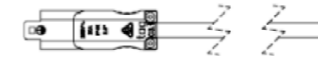

CABLE TYPE: 3 CORE x 1.5mm<sup>2</sup>  
DESCRIPTION: C-CONNECTOR LEAD  
COLOUR: WHITE OR BLACK  
(REFER TO PURCHASE ORDER)  
LENGTH (mm):

xx	LENGTH (mm)
05	500
10	1000
15	1500
20	2000
25	2500
30	3000
35	3500
40	4000
45	4500
50	5000

NOTE:



CABLE TYPE: 3 CORE x 1.5mm<sup>2</sup>  
DESCRIPTION: GST PLUG LEAD  
COLOUR: WHITE OR BLACK  
(REFER TO PURCHASE ORDER)  
LENGTH (mm):

xx	LENGTH (mm)
05	500
10	1000
15	1500
20	2000
25	2500
30	3000
35	3500
40	4000
45	4500
50	5000

NOTE:

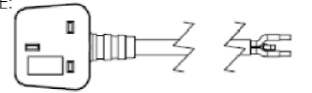

CABLE TYPE: 3 CORE x 1.5mm<sup>2</sup>  
DESCRIPTION: BRITISH 13A PLUG LEAD  
COLOUR: WHITE OR BLACK  
(REFER TO PURCHASE ORDER)  
LENGTH (mm):

xx	LENGTH (mm)
05	500
10	1000
15	1500
20	2000
25	2500
30	3000
35	3500
40	4000
45	4500
50	5000

COLOUR VARIATIONS

PART NUMBER	DESCRIPTION
W	WHITE BODY & CLAMP
B	BLACK BODY & CLAMP
1	WHITE DECAL GLOSS
2	WHITE DECAL MATT
3	BLACK DECAL GLOSS
4	BLACK DECAL MATT
LUX DECAL OPTIONS	
BSB	PRESTIGE GOLD, SATIN (BRUSHED)
BZB	QUARTZ BRONZE SATIN (BRUSHED)
SSB	STAINLESS STEEL NO.4 (BRUSHED)
BSM	PRESTIGE GOLD GRANEX (MATTE)
BZM	QUARTZ BRONZE GRANEX (MATTE)
SSM	NATURAL GRANEX (MATTE)
BKM	BLACK GRANEX (MATTE)
FABRIC FINISH REFER TO LU41144	
A	FABRIC COLOUR 1 - VANILA
B	FABRIC COLOUR 2 - SMOKE
C	FABRIC COLOUR 3 - IRON FORMERLY KNOWN AS CHARCOAL
D	FABRIC COLOUR 4 - CHARCOAL FORMERLY KNOWN AS BLACK

PART NUMBER: (REFER CONFIGURATION)xxXX

NOTE - \* - CLAMP TYPE - (S = ABOVE DESK OR Z = UNDER DESK)

1 - USB (V = 100W USB A+C, K = C+C OR Q = 118W USB A+C, M = C+C OR Y = 140W USB A+C, S = C+C)

X - LEAD TYPE (BS PLUG = G), (GST CONNECTOR = W), (C3.1 CONNECTOR = C)

xx - LENGTH - 05 / 10 / 15 / 20 / 25 / 30 / 35 / 40 / 45 / 50

XX - COLOUR - W / B + 1 / 2 / 3 / 4 + (OPTIONAL) A / B / C / D

CUSTOMER SIGNATURE:	TOLERANCES UNLESS OTHERWISE STATED:	 <b>CMS Electracom</b> COPYRIGHT © 2020	
MATERIAL: PC FR	X ±0.5 X.X ±0.2 X.XX ±0.1 X.XXX ±0.05 ANG ±0.5°	TITLE: NOVA DUO XL UK NON-FUSED CONFIGURATIONS	
FINISH: FINE EDM / POLISHED / FABRIC		DRAWING: LU39644	REV: 7
COLOUR: REFER TABLE		A3	
THIS DRAWING & ASSOCIATED CAD FILES ARE ISSUED IN THE STRICTEST CONFIDENCE AND ARE ONLY TO BE USED IN THE COMMERCIAL INTERESTS OF CMS ELECTRACOM PTY LTD	DRAWN IN mm TO AS1100 DO NOT SCALE	SCALE 1:2	SHEET 2 OF 14