

FRONT VIEW

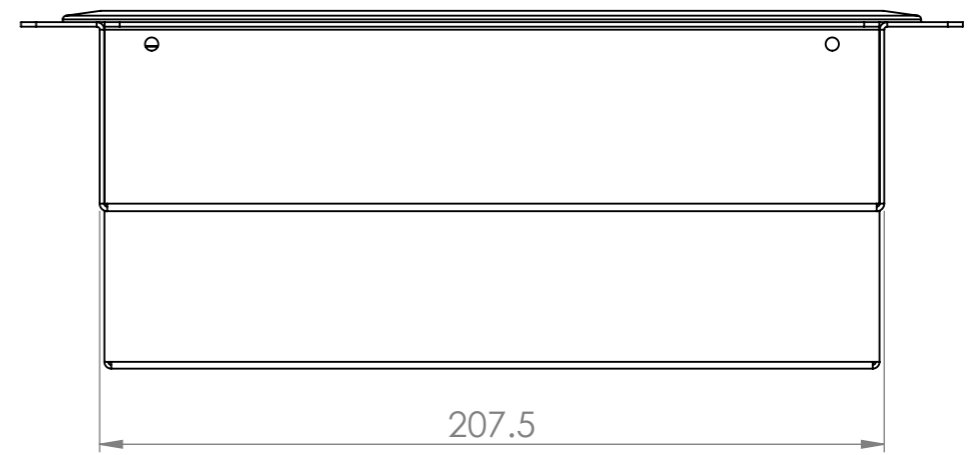

END VIEW

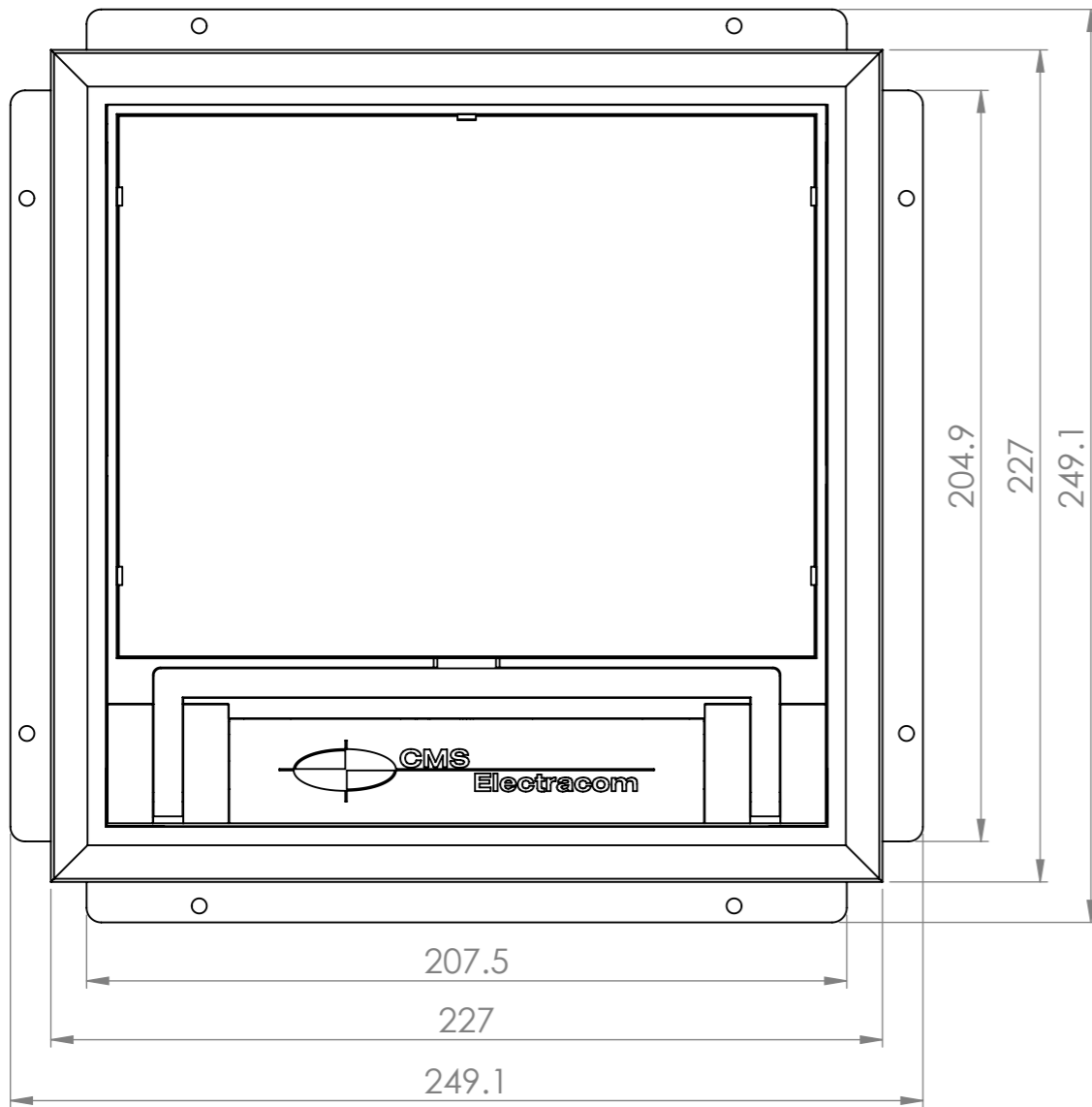

TOP VIEW

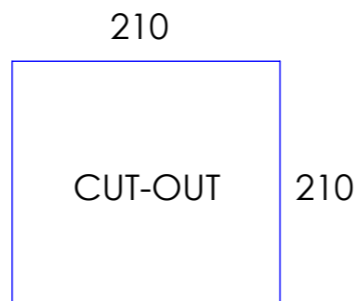
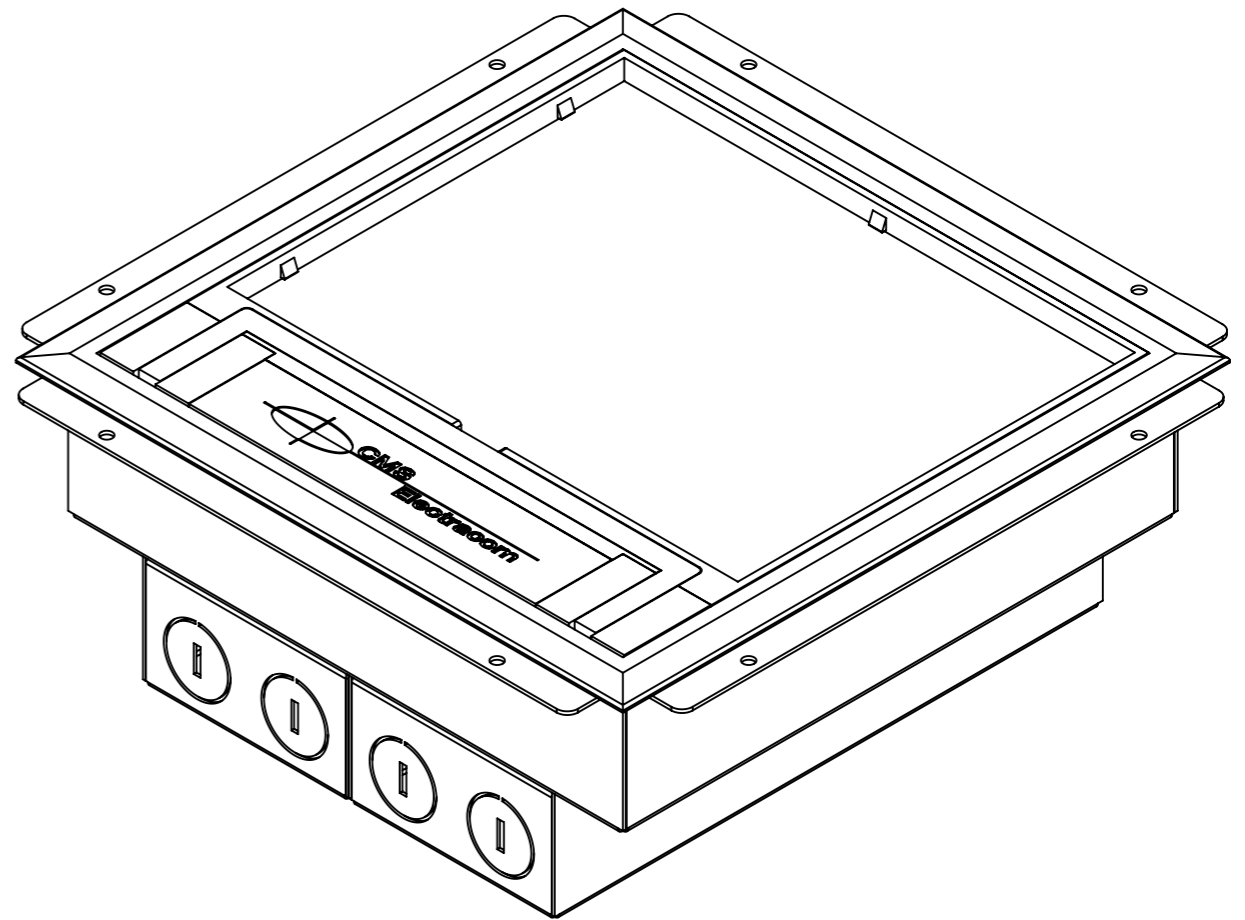

REVISION HISTORY		UNLESS OTHERWISE SPECIFIED: DIMENSIONS ARE IN MILLIMETERS		DO NOT SCALE DRAWING		REVISION 2	
DATE	MODIFICATIONS	TOLERANCES					
23/08/11	ISSUED FOR MANUFACTURING	0.00 ± 0.02	ANGULAR ± 0.5°				
07/05/13	MODIFIED CHASSIS	0.0 ± 0.1		TITLE: FL2090			
		0 ± 0.5					
		DEBUR AND BREAK SHARP EDGES		THE MATERIAL CONTAINED HEREIN IS THE SOLE PROPERTY OF CMS ELECTRACOM. ANY UNAUTHORIZED REPRODUCTIONS, MODIFICATIONS AND / OR DISTRIBUTION IS STRICTLY PROHIBITED.			
		NAME	DATE	DWG NO.		LU-2408	
		LUCKY	07/05/13	PART NO.		TBC	
		MATERIAL: X		SCALE		NTS	
		FINISH: X		SHEET		1 OF 2	
		FILE ON SHARED\CAD:		A3			
		H:\Melbourne\CAD\Current Production Drawings					
		FILE ON NAS:					
		Z:\Work files\Floor boxes\FL1\FL1R2					

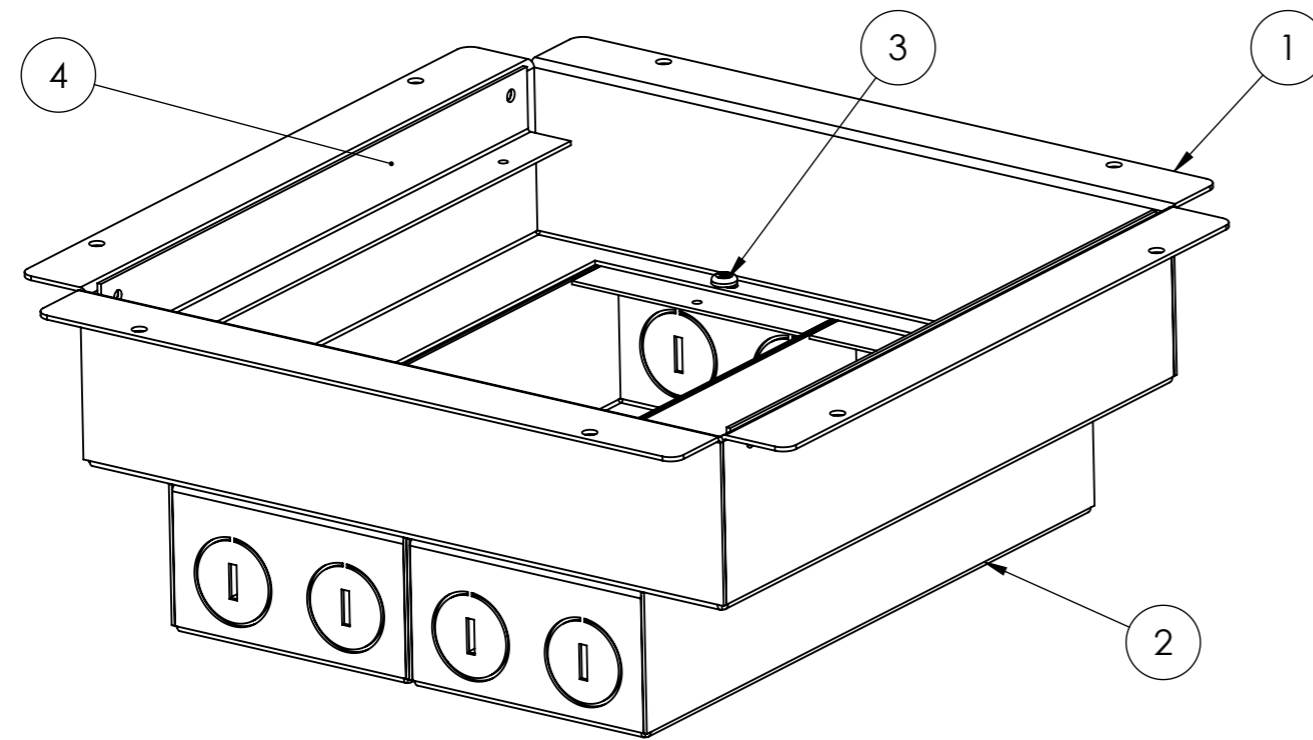
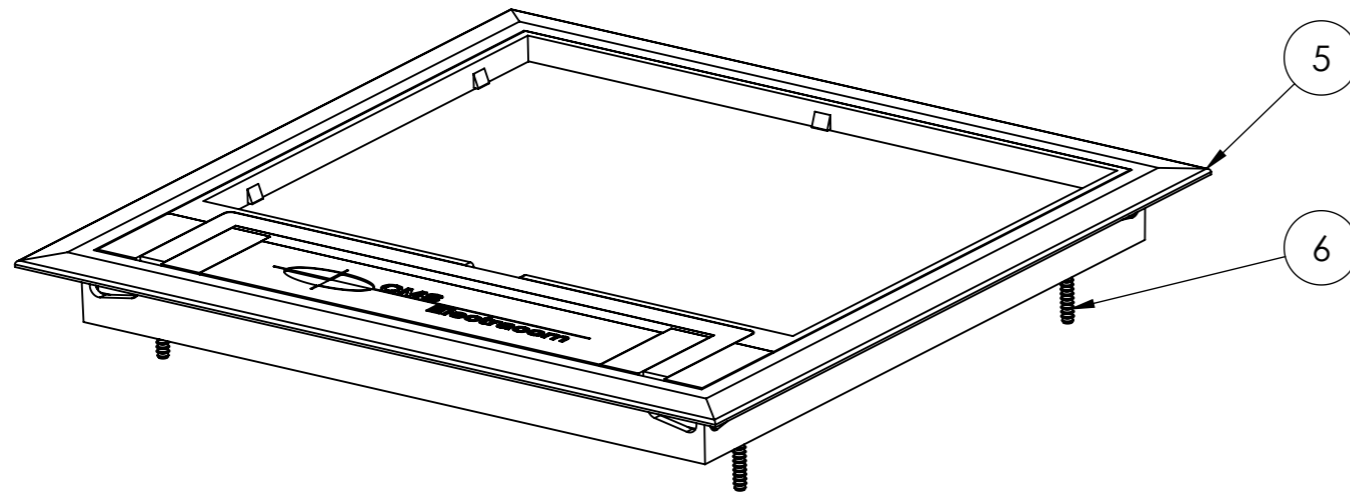

ITEM NO.	PART NUMBER	QTY.
1	LU2409_V2_CMS Floor box CL90 small undercarriage	1
2	LU1408_V5_Accessories box extended	2
3	6G x 3/8" pan head screw	4
4	LU1697_V1_CMS floor box 60mm small undercarriage support bracket.	2
5	Apollo FB2 lid	1
6	6G x 3/4" blind CSK screw (To fix lid)	4

REVISION HISTORY		UNLESS OTHERWISE SPECIFIED: DIMENSIONS ARE IN MILLIMETERS		DO NOT SCALE DRAWING		REVISION 2	
DATE	MODIFICATIONS	TOLERANCES		 TITLE: FL2090			
23/08/11	ISSUED FOR MANUFACTURING	0.00 ± 0.02	ANGULAR ± 0.5°				
07/05/13	MODIFIED CHASSIS	0.0 ± 0.1		THE MATERIAL CONTAINED HEREIN IS THE SOLE PROPERTY OF CMS ELECTRACOM. ANY UNAUTHORIZED REPRODUCTIONS, MODIFICATIONS AND / OR DISTRIBUTION IS STRICTLY PROHIBITED.			
		DEBUR AND BREAK SHARP EDGES		NAME		DATE	
				LUCKY		07/05/13	
		MATERIAL: X		DWG NO.		LU-2408	
		FINISH: X		PART NO.		TBC	
		FILE ON SHARED\CAD:		SCALE		NTS	
		H:\Melbourne\CAD\Current Production Drawings		SHEET		2 OF 2	
		FILE ON NAS:		A3			
		Z:\Work\Bier\Floor boxes\FL\FL_V12					