

# Tag

## Plug & Socket Couplers Installation Instructions

Installation couplers:

- Are to be fully engaged; with no significant gap, and the retaining arms latched as shown -

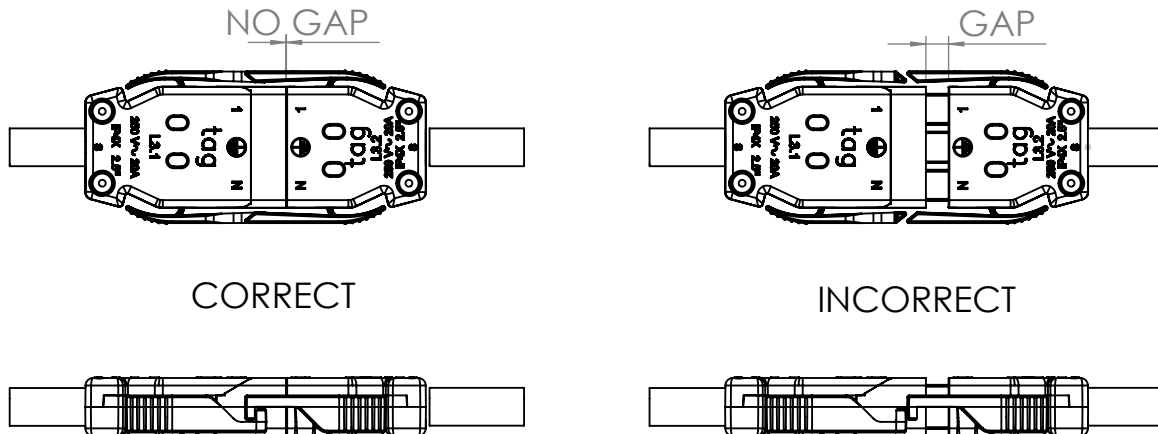

- Are to be engaged and dis-engaged without load only.
- Are not suitable for readily accessible areas.
- Are not to be considered as a replacement for the national domestic plug and socket outlet-systems.
- Are not to be placed under excessive strain; in case of doubt, fix cable and couplers.
- Are to be placed to distribute the load between outlets as evenly as possible ensuring that the sum of all loads does not overload the input coupler and cable.
- Dangerous compatibility between different coupler systems is not automatically prevented by the couplers compliance with AS/NZS 61535.
- Are to be installed, connected and tested in accordance with AS/NZS 3000 (Australian/New Zealand Wiring Rules & Regulations).
- Do not penetrate connector housings or lead as these contain live parts

**DO NOT INSERT TEST PROBES LARGER THAN 0.8MM WIDE AS YOU WILL DAMAGE THE CONTACTS**

Test plugs are supplied with the starter sockets. Additional test plugs are available, free of charge, by contacting our sales team.

Australia : 1300 159 159    New Zealand: 09 582 0776

[www.cmselectra.com](http://www.cmselectra.com)