

Retractable Cable Reel Instruction Manual

NOTE: ELECTRICAL WIRING TO BE CARRIED OUT BY A SUITABLY QUALIFIED PERSON

IF THE SUPPLY CORD IS DAMAGED, IT SHALL BE REPLACED BY THE MANUFACTURER OR ITS SERVICE AGENT OR SIMILARLY QUALIFIED PERSON IN ORDER TO AVOID HAZARD

DISCONNECT THE EQUIPMENT FROM MAIN SUPPLY BEFORE OPENING COVER

MOUNTING HOLE POSITIONS

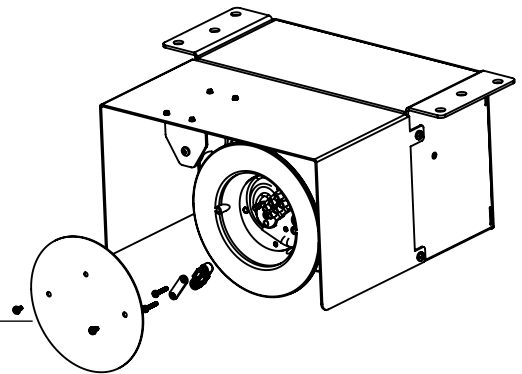
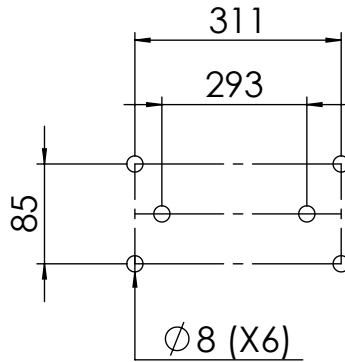
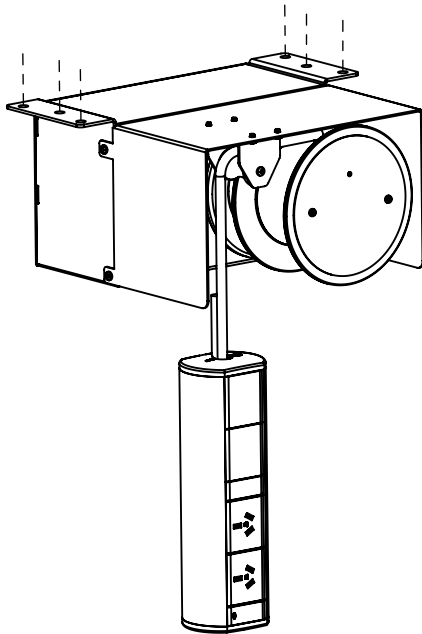

Remove cover plate and cable strain components

Cut cable to length travel needed

Feed cable through the roller and around the cable reel do at least **ONE** loop then feed through to the centre

Strip cable after the cable strain plate

Connect wires to the terminal block in respective screw terminals

Black - Negative
Red - Positive
Green/Yellow - Earth

Secure cable strain plate using the 2 x M3 screws

Screw the cover plate back to the cable Reel

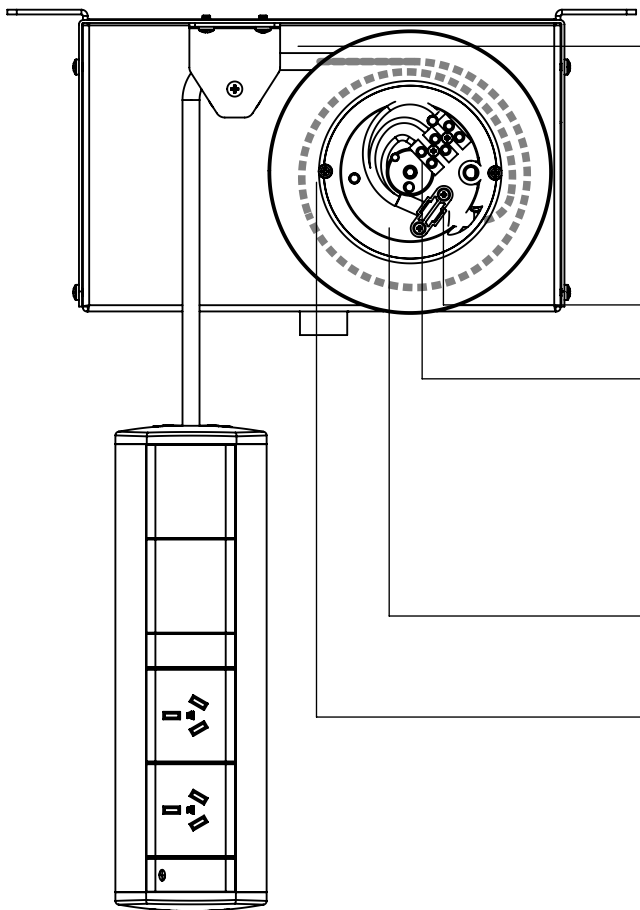

Retractable Cable Reel Instruction Manual

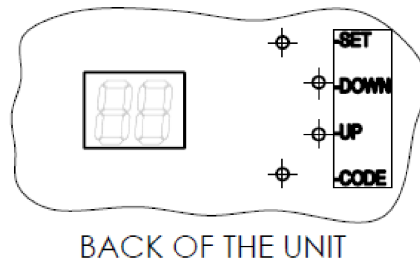

Setting Up and Down Positions

Press and hold **SET** until screen displays **P1**, press **SET** again, Display will show **OP**. Press and hold **DOWN** until the pendant is in correct position for use, then press **SET** Display will show **CL**. Press and hold **UP** until pendant is in correct home position, then press **SET**

The pendant will now move to the home positions automatically to map the up and down sensitivity force requirements.

Setting force overload

Press and hold **SET** until screen displays **P1**, press **DOWN** once, display will show **P2**, Press **SET** once again. Display will show **F5**. Press **UP** until the display shows **F1**. Press **SET** to confirm setting. Display will show -- to show setting is complete.

RF SWITCH INCLUDED WITH UNIT
CONTROL UP TO FOUR ON ONE SWITCH PLATE
OR UNIT CAN BE HARDWIRED TO A STANDARD
WALL PLATE USING A BELL PRESS SWITCH
USING 1MM FIGURE 8 FLEXABLE CABLE

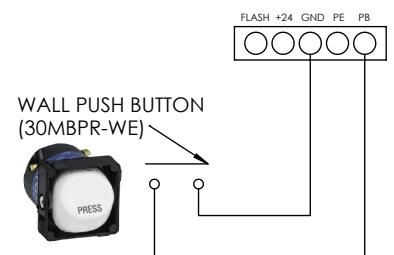

WIRING DIAGRAM FOR MOMENTARY SWITCH TO THE TERMINAL BLOCK AT THE BOTTOM OF THE UNIT

Adding transmitters and RF switches

Press and hold **CODE** until screen displays **SU**,
Press a button you would like to set on the transmitter, then release and press the same button again.
Display will flash **SU** then
Display will show -- to show setting is complete.

To Cancel stored codes:

Press and hold **CODE** for more than 8 seconds until it flashes **dL**

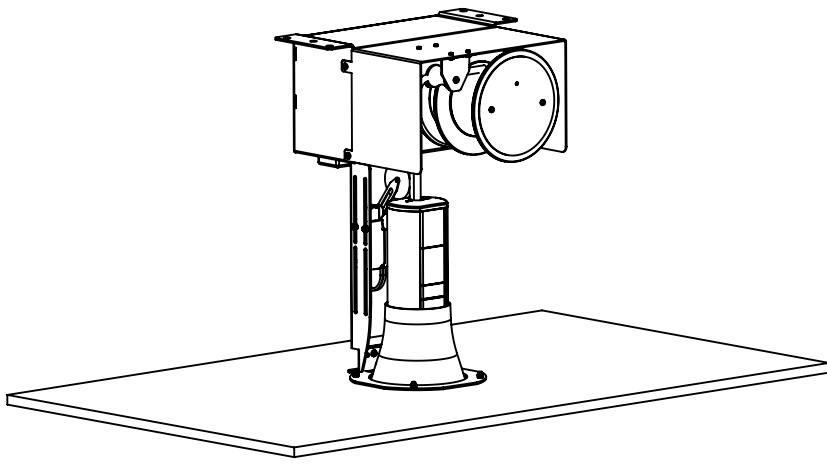

Retractable Cable Reel Instruction Manual

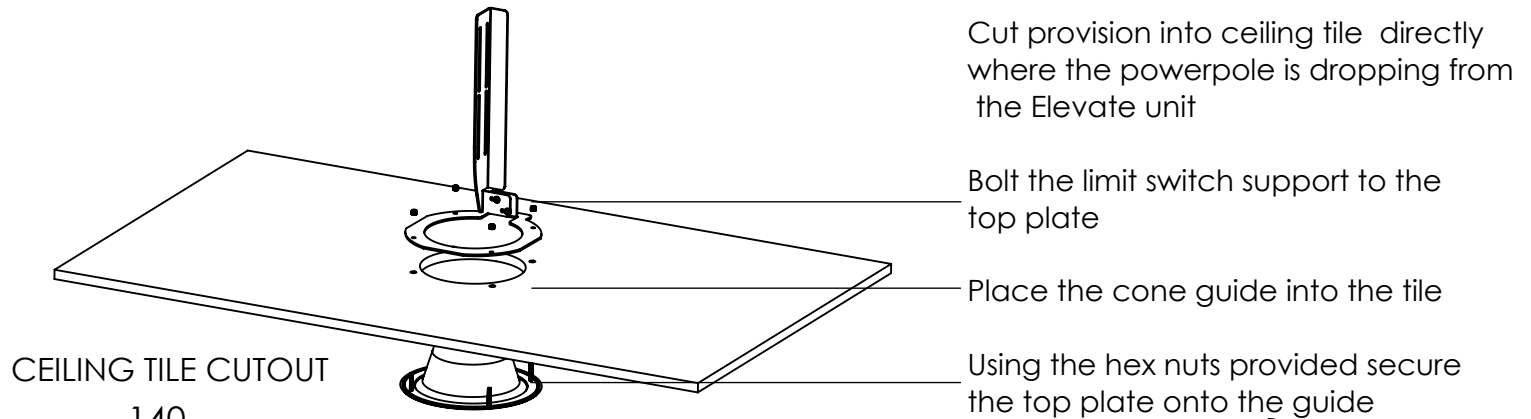

CEILING TILE CUTOUT

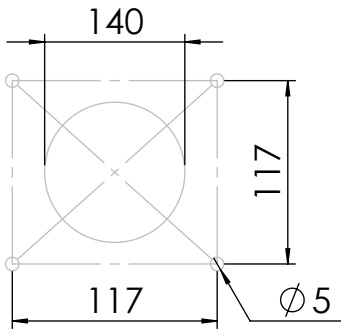

Secure the limit switch control box onto the bottom of the elevate

Plug the connector into the box

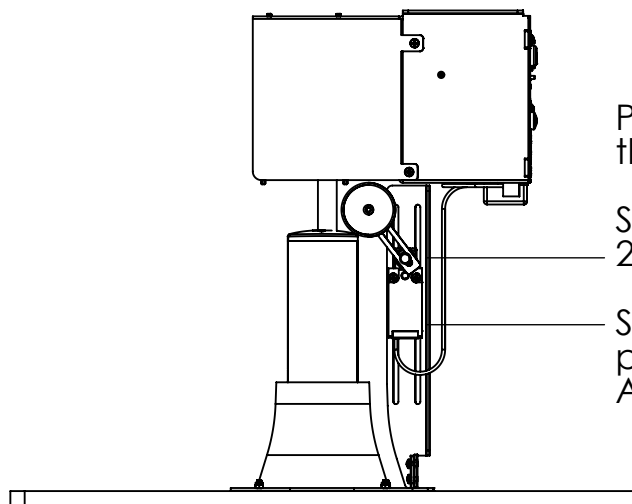
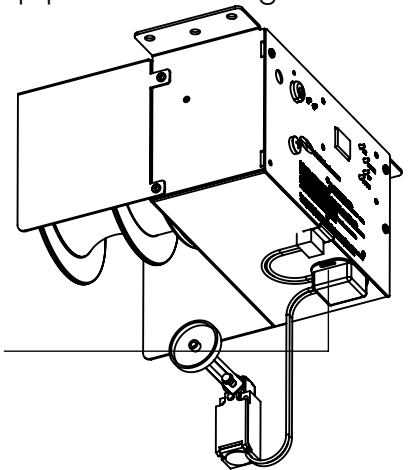

Position the power pole so the bottom of it is flush to the ceiling tile

Secure limit switch to bract using 2 x M4 screws and hex nuts

Swing arm should be placed so the powerpole activates it 10mm below ceiling tile
Arm can be adjusted to suit

