

AU/NZ SOCKET OUTLET = AU

USE LU21933 WHEN INSTALLING GPO

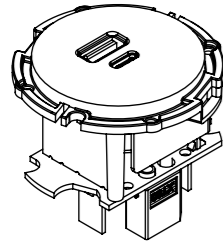

140W DC USB AC MODULE = U

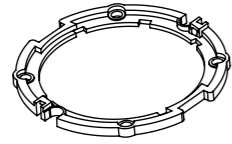
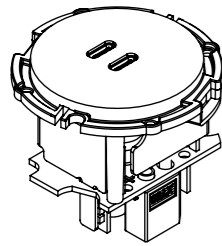

140W DC USB CC MODULE = UC

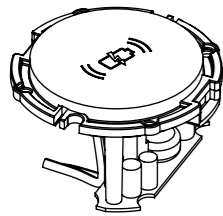

DC WIRELESS CHARGING MODULE = W

FACTORY ONLY INSERTABLE MODULES
REFER PAGE 2 FOR
MODULE CONFIGURATION

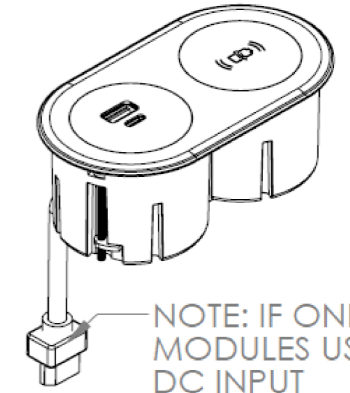
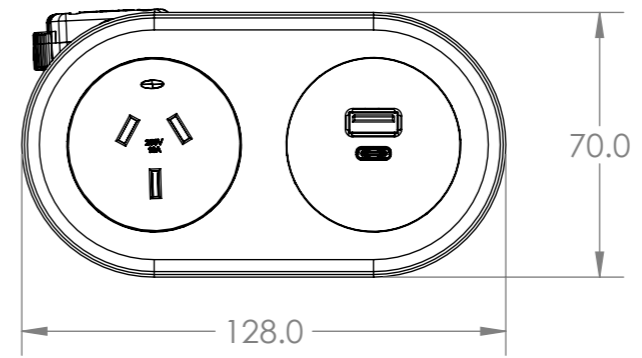
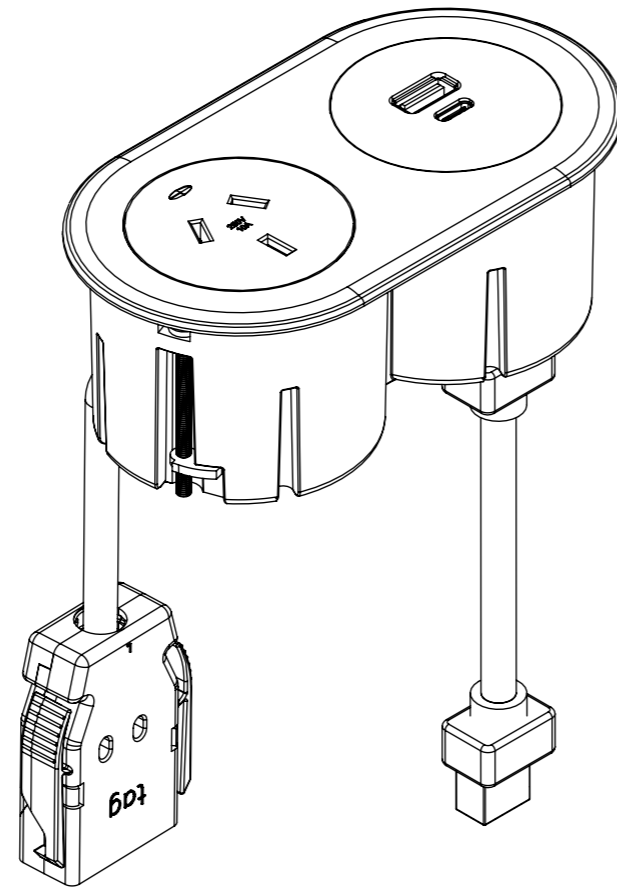

NOTE: IF ONLY DC MODULES USED, DC INPUT THROUGH HERE

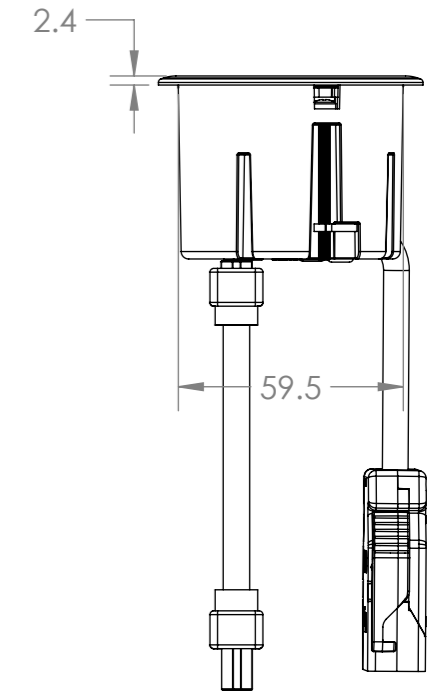
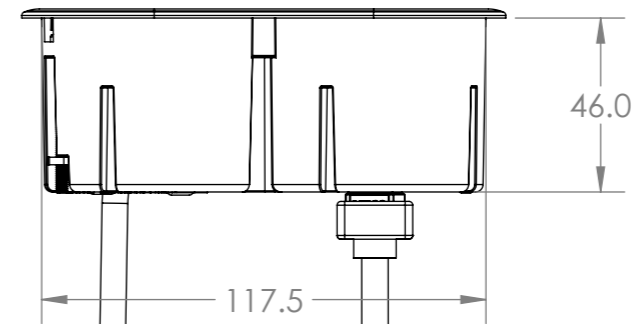

A.C INPUT FOR CONFIGURATIONS WITH AU/NZ SOCKET

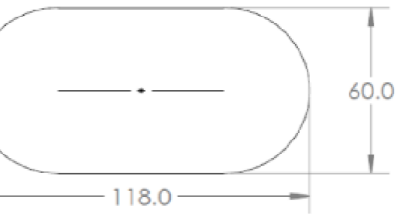

ROUTING CUTOUT
118mm x 60mm
-0/+1mm

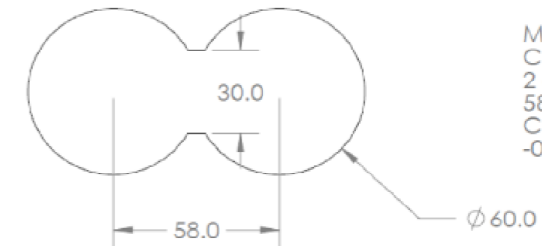

MANUAL HOLESAW CUTOUT
2 off 60mm HOLES
58mm PITCH
CUT FLATS 30mm
-0/+1mm

REV	DESCRIPTION	DATE	DRWN	APPV
7	140W USB C+C CONFIGURATIONS ADDED	7/4/2025	JB	RG
6	DC INPUT UPDATED	22/5/2024	JB	RG
5	WIRING DIAGRAM UPDATED	29/1/2024	JB	RG
4	CONFIGURATIONS UPDATED	9/1/2024	JB	RG
3	CHANGED TOLERANCE FROM 2mm TO 1mm	3/05/2023	GC	AP
2	WIRING DIAGRAM UPDATED	7/2/2023	JB	RG
1	RELEASED FOR PRODUCTION	16/1/2023	JB	RG
REVISIONS				

CUSTOMER SIGNATURE:
MATERIAL: PC-FR
FINISH: TEXTURED
COLOUR: WHITE OR BLACK
THIS DRAWING & ASSOCIATED CAD FILES ARE ISSUED IN THE STRICTEST CONFIDENCE AND ARE ONLY TO BE USED IN THE COMMERCIAL INTERESTS OF CMS ELECTRACOM PTY LTD

TOLERANCES UNLESS OTHERWISE STATED: X ±0.5 X.X ±0.2 X.XX ±0.1 X.XXX ±0.05 ANG ±0.5°
DRAWN IN mm TO AS1100 DO NOT SCALE

 **CMS Electracom** COPYRIGHT © 2015

TITLE:
AU MULTI 2 ECHO DC CONFIGURATIONS

DRAWING: LU41660 **REV:** 7 **A3**

SCALE 1:2 SHEET 1 OF 5

NOTE: ONLY APPLICABLE WITH AU SOCKET

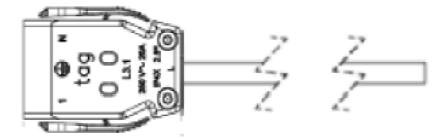

CABLE TYPE: 2.5MM
 DESCRIPTION: TAG CONNECTOR LEAD
 COLOUR: WHITE OR BLACK
 (REFER TO PURCHASE ORDER)
 LENGTH (mm):

xx	LENGTH (mm)
05	500
10	1000
15	1500
20	2000
25	2500
30	3000
35	3500
40	4000
45	4500
50	5000

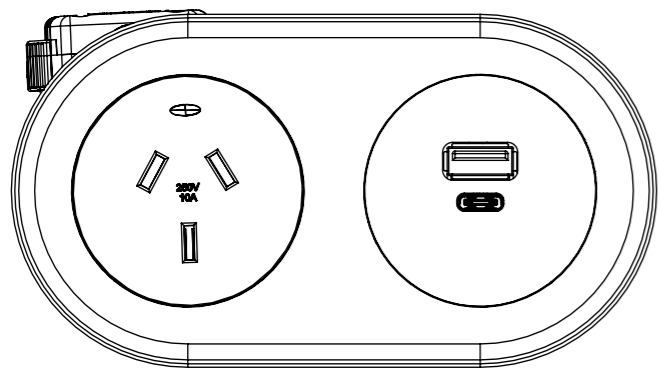

FREDA1UXxxDXX

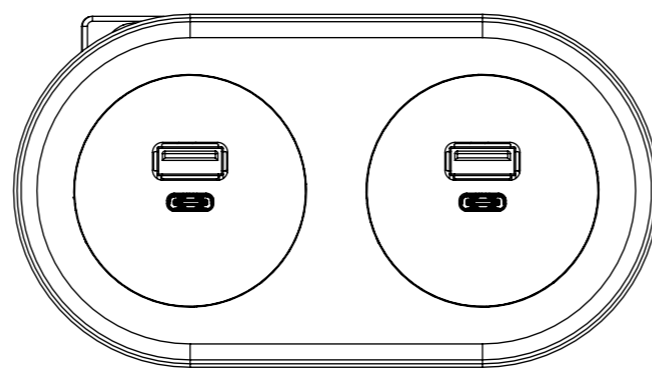

FREDUUXxxXX

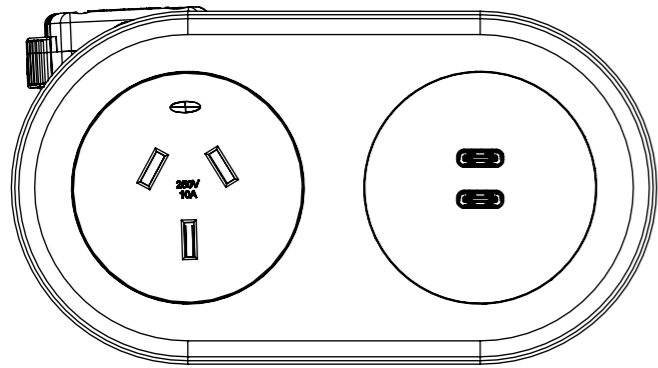

FREDA1UCXxxDXX

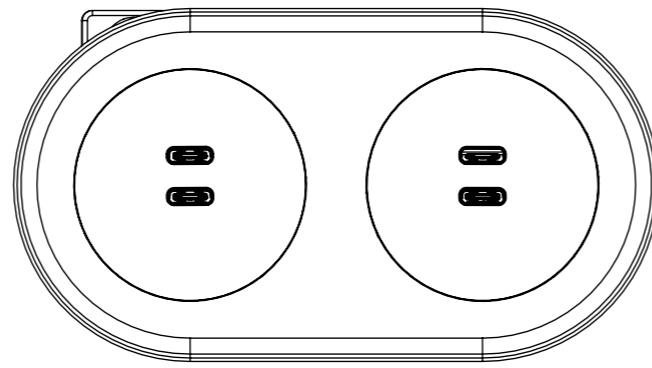

FREDUCUCXxxXX

NOTE: ONLY APPLICABLE WITH AU SOCKET

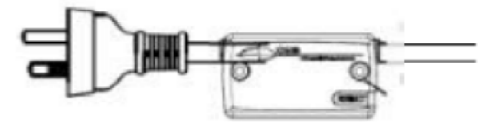

CABLE TYPE: 1MM
 DESCRIPTION: AUSTRALIAN PLUG LEAD
 WITH THERMAL OVERLOAD
 COLOUR: WHITE OR BLACK
 (REFER TO PURCHASE ORDER)
 LENGTH (mm):

xx	LENGTH (mm)
05	500
10	1000
15	1500
20	2000
25	2500
30	3000
35	3500
40	4000
45	4500
50	5000

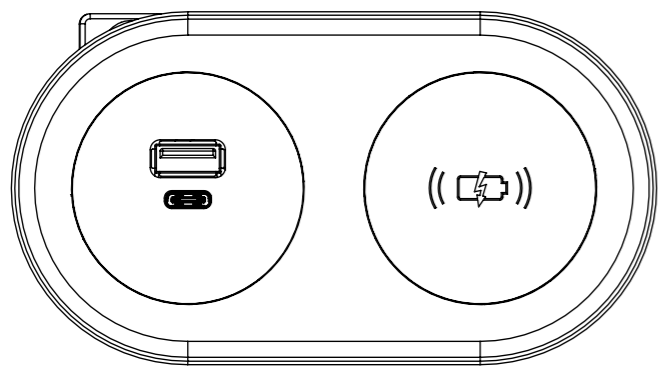

FREDUWXxxXX

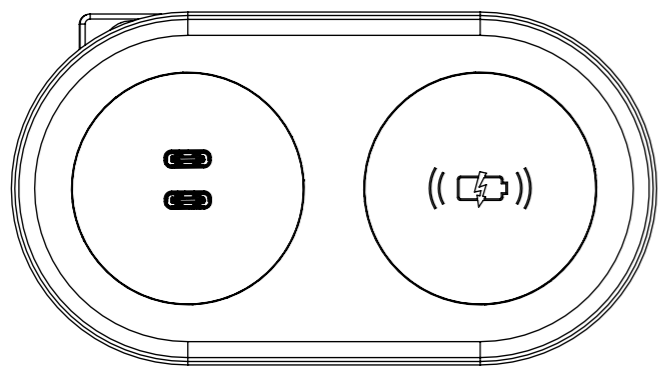

FREDUCWXxxXX

PART NUMBER: FREDA1UXxxDXX

NOTE - X - LEAD TYPE (TAG = T OR 3PIN PLUG = A)

xx - LENGTH - 05 / 10 / 15 / 20 / 25 / 30 / 35 / 40 / 45 / 50

XX - COLOUR - WT / BK

CUSTOMER SIGNATURE:	TOLERANCES UNLESS OTHERWISE STATED: X ±0.5 X.X ±0.2 X.XX ±0.1 X.XXX ±0.05 ANG ±0.5°	 CMS Electracom COPYRIGHT © 2015		
MATERIAL:				TITLE: AU MULTI 2 ECHO DC CONFIGURATIONS
FINISH:		PC-FR TEXTURED WHITE OR BLACK	DRAWING:	REV:
COLOUR:			LU41660	7
THIS DRAWING & ASSOCIATED CAD FILES ARE ISSUED IN THE STRICTEST CONFIDENCE AND ARE ONLY TO BE USED IN THE COMMERCIAL INTERESTS OF CMS ELECTRACOM PTY LTD		DRAWN IN mm TO AS1100 DO NOT SCALE	SCALE 1:2	SHEET 2 OF 5

A3