

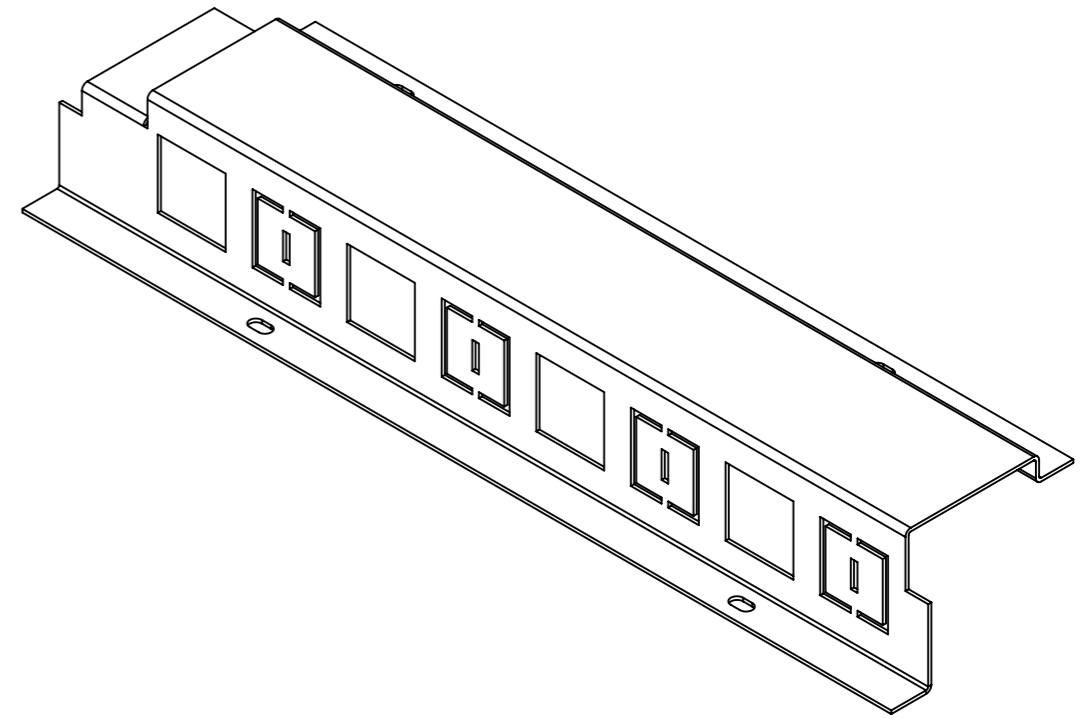

REVISION HISTORY		UNLESS OTHERWISE SPECIFIED: DIMENSIONS ARE IN MILLIMETERS		DO NOT SCALE DRAWING		REVISION 1	
N.	DATE	MODIFICATIONS		TOLERANCES		TITLE:	
1	22/03/12	ISSUED FOR MANUFACTURING		0.00 ± 0.02 ANGULAR ± 0.5°		 FB4060 RH data plate	
2				0.0 ± 0.1			
3				0 ± 0.5		DWG NO. LU-3325 PART NO. TBC	
4				DEBUR AND BREAK SHARP EDGES			
5				THE MATERIAL CONTAINED HEREIN IS THE SOLE PROPERTY OF CMS ELECTRACOM. ANY UNAUTHORIZED REPRODUCTIONS, MODIFICATIONS AND / OR DISTRIBUTION IS STRICTLY PROHIBITED.		SCALE 1:1 SHEET 1 OF 2	
6				NAME DATE			
7				LUCKY 22/03/12		A3	
8				MATERIAL: 1.2mm Steel			
9				FINISH: Powder coat black satin			
10				FILE ON SHARED\CAD: Current Production Drawings			
11				FILE ON NAS: Z:\Work files\Floor boxes\CMS floor box\Production\60mm\Large\Plates			
12							
13							

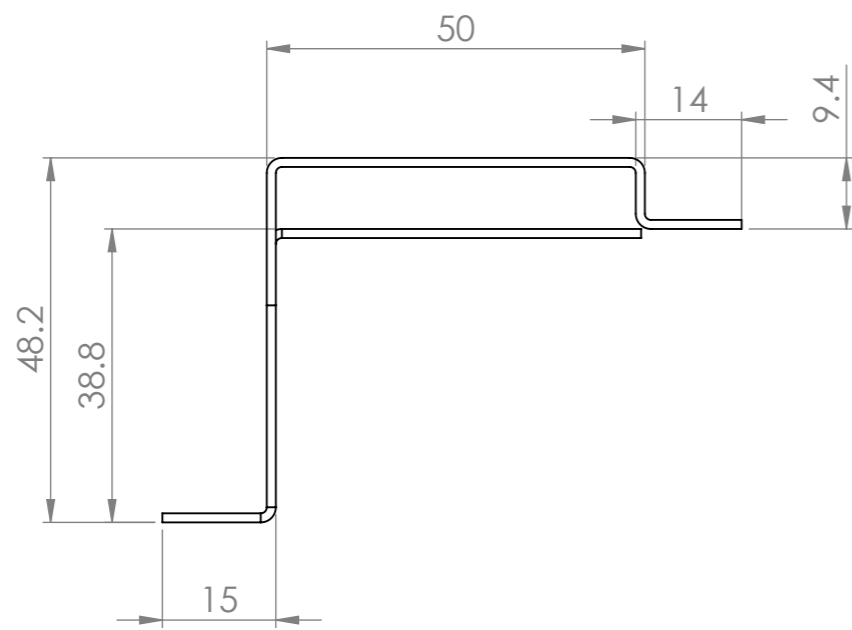
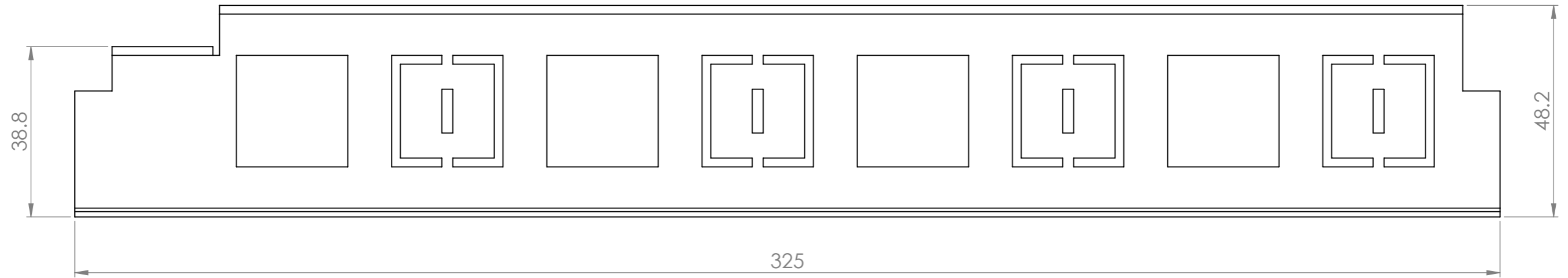

REVISION HISTORY		UNLESS OTHERWISE SPECIFIED: DIMENSIONS ARE IN MILLIMETERS		DO NOT SCALE DRAWING		REVISION	
N.	DATE	MODIFICATIONS		TOLERANCES		1	
1	22/03/12	ISSUED FOR MANUFACTURING		0.00 ± 0.02 ANGULAR ± 0.5°		 TITLE: FB4060 RH data plate	
2				0.0 ± 0.1			
3				0 ± 0.5			
4				DEBUR AND BREAK SHARP EDGES		DWG NO. LU-3325 PART NO. TBC SCALE N/A SHEET 2 OF 2	
5				THE MATERIAL CONTAINED HEREIN IS THE SOLE PROPERTY OF CMS ELECTRACOM. ANY UNAUTHORIZED REPRODUCTIONS, MODIFICATIONS AND / OR DISTRIBUTION IS STRICTLY PROHIBITED.			
6				NAME DATE			
7				LUCKY 22/03/12		A3	
8				MATERIAL: 1.2mm Steel			
9				FINISH: Powder coat black satin			
10				FILE ON SHARED\CAD: H:\Melbourne\CAD\Current Production Drawings			
11				FILE ON NAS: Z:\Work files\Floor boxes\CMS floor box\Production\60mm\Large\Plates			
12							
13							