

# NEO Deskbox installation instruction

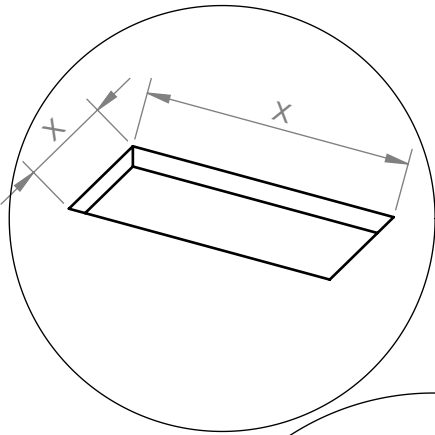

DETERMINE CUTOUT OF  
MODEL NUMBER FROM RELATED DRAWING

CUTOUT SIZE INCLUDES ANY EDGE FINISHING

POSITION DESKBOX UNDER DESK INTO CUTOUT  
AND SCREW FIX INTO PLACE  
(LEAVE SCREWS SLIGHTLY LOOSE TO  
ADJUST FINAL POSITION THEN TIGHTEN)  
USE WASHERS PROVIDED TO FIT BETWEEN UNDERCARRIAGE  
AND DESK IF LID TO DESK HEIGHT NEEDS ADJUSTING

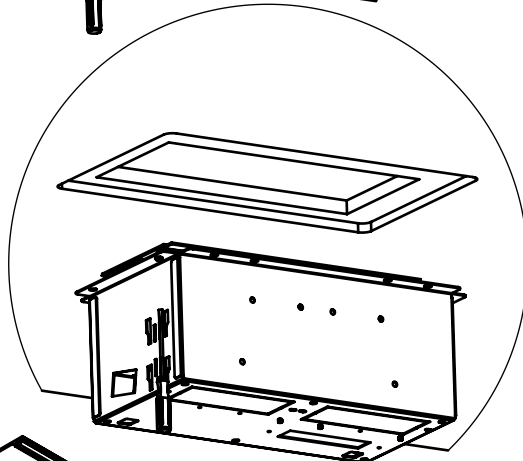
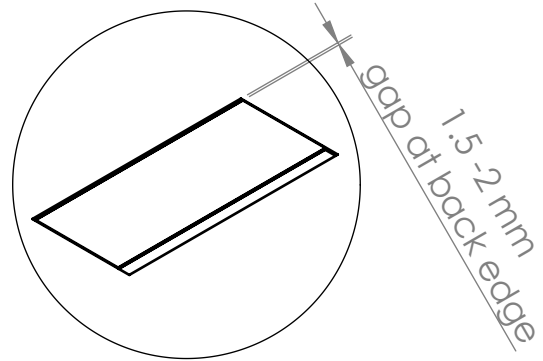
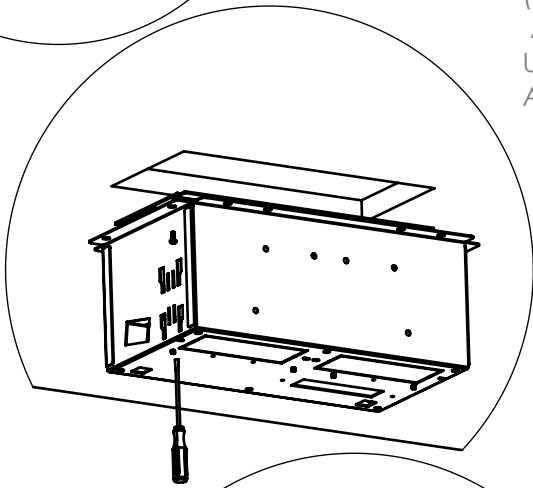

25mm IS THE DEFAULT SETTING FOR THE LID HEIGHT,  
TO SET FOR THICKER DESKS REBATE THE UNDERSIDE  
OF THICK DESKS TO REDUCE TO 25mm THICKNESS  
REBATE DETAIL IS ON MODEL RELATED DRAWING

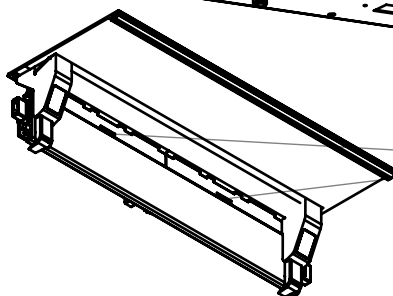

TO REMOVE LID TO LAMINATE TOP SURFACE  
PUSH IN BOTH TABS AND REMOVE LID  
NOTE: HINGE ASSEMBLY WILL STAY ATTACHED  
TO THE LID, DO NOT REMOVE WHEN LAMINATING  
WHEN INSTALLING PUSH LID ASSEMBLY INTO  
FIXING BAR UNTIL CLIPS ENGAGE

NOTE: CUTOUT WIDTH AND REBATE DEPTH SIZE MAY  
NEED TO BE ADJUSTED BY THICKNESS OF LAMINATE APPLIED