

TOP

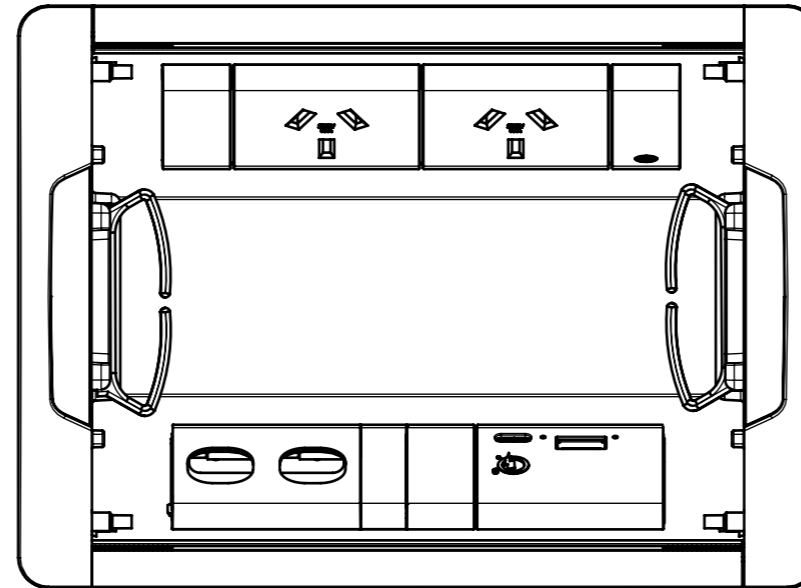

TOP NO LID

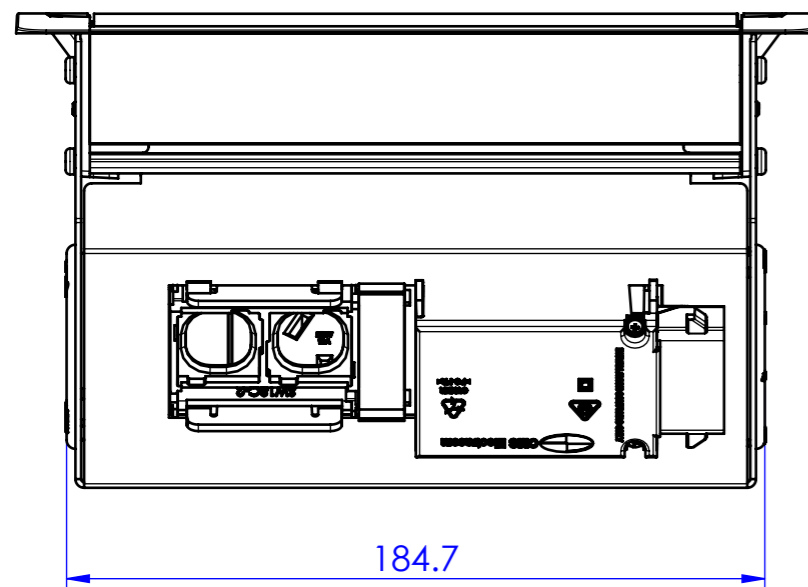
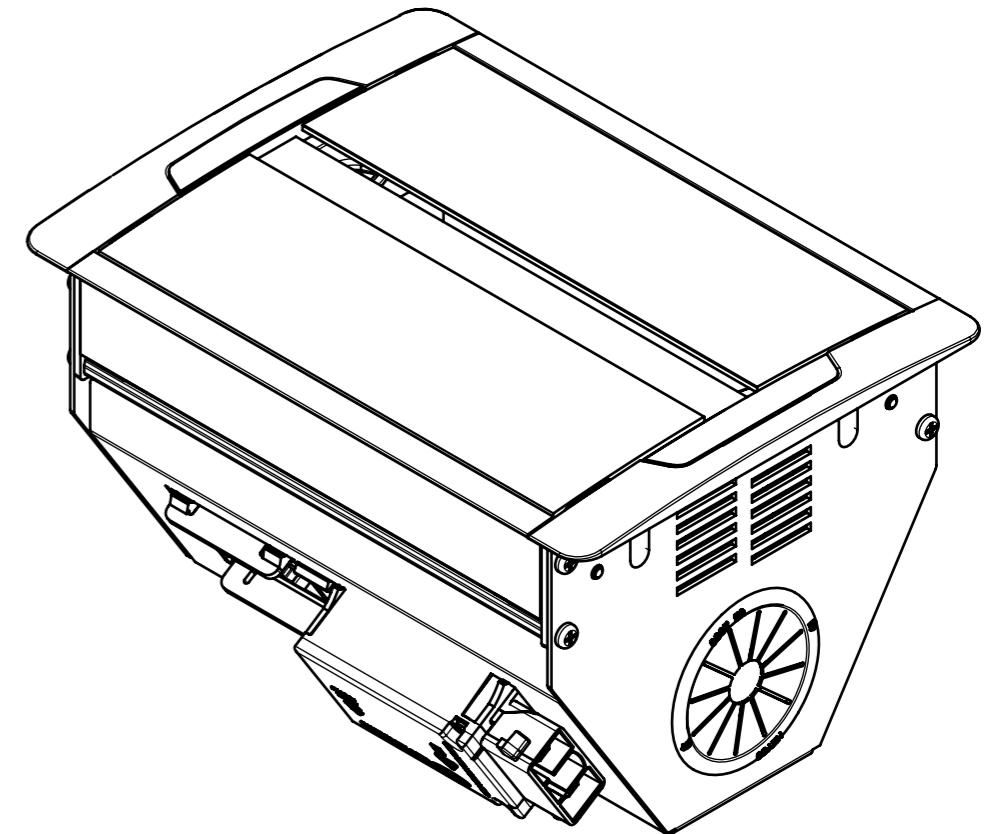

184.7
FRONT

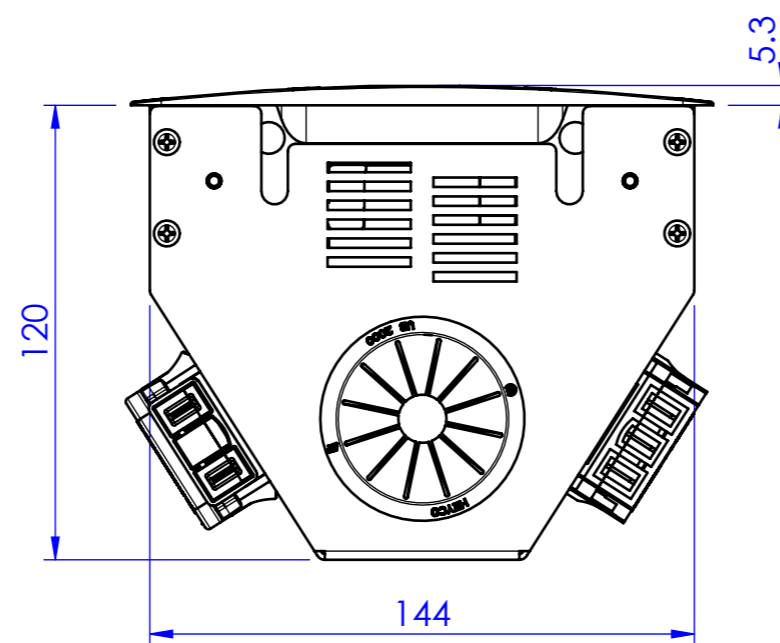

120
144
5.3
SIDE

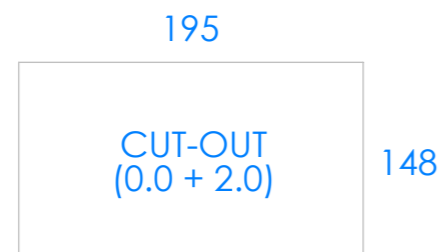

CUSTOMER SIGNATURE:	
MATERIAL:	ALUMINIUM
FINISH:	VARIOUS
COLOUR:	VARIOUS

TOLERANCES UNLESS OTHERWISE STATED:

X ±0.5
X.X ±0.2
X.XX ±0.1
X.XXX ±0.05
ANG ±0.5°



TITLE:
ACD0204 2GPO USB DATA

DRAWING: LU31954	REV: 1	A3
----------------------------	------------------	-----------

THIS DRAWING & ASSOCIATED CAD FILES ARE ISSUED IN THE STRICTEST CONFIDENCE AND ARE ONLY TO BE USED IN THE COMMERCIAL INTERESTS OF CMS ELECTRACOM PTY LTD

DRAWN IN mm TO AS1100 DO NOT SCALE



SCALE 1:2	SHEET 1 OF 1
-----------	--------------

1	RELEASED FOR PRODUCTION	05/09/2017	AP	AP
REV	DESCRIPTION	DATE	DRWN	APPV
REVISIONS				