

|  |  |   |  |  |  |
|--|--|---|--|--|--|
| <b>MATERIAL:</b><br>ALUMINIUM / POLYCARBONATE  |  | <b>TOLERANCES UNLESS OTHERWISE STATED:</b><br>X ±0.5<br>X.X ±0.2<br>X.XX ±0.1<br>X.XXX ±0.05<br>ANG ±0.5° |  |  <b>CMS Electracom</b> COPYRIGHT © 2015 |  |
| <b>FINISH:</b><br>ANODISED / FINE EDM  |  |   |  | <b>TITLE:</b><br>ACCEDE WITH SW1804 + SW18UAC3 + 4 DATA  |  |
| <b>COLOUR:</b><br>VARIOUS / SILVER   |  |   |  | <b>DRAWING:</b><br>LU39377   |  |
| THIS DRAWING & ASSOCIATED CAD FILES ARE ISSUED IN THE STRICTEST CONFIDENCE AND ARE ONLY TO BE USED IN THE COMMERCIAL INTERESTS OF CMS ELECTRACOM PTY LTD |  | DRAWN IN mm TO AS1100 DO NOT SCALE  |  | <b>REV:</b><br>2   |  |
|  |  |   |  | <b>A3</b>  |  |
|  |  |   |  | SCALE 1:5  |  |
|  |  |   |  | SHEET 1 OF 2   |  |

| REV       | DESCRIPTION                                 | DATE       | DRWN | APPV |
|-----------|---|------------|------|------|
| 2         | RELEASED FOR PRODUCTION                     | 1/12/2021  | JB   | RG   |
| 1         | RELEASED FOR QUOTATION - NOT FOR PRODUCTION | 12/11/2021 | JB   | RG   |
| REVISIONS |   |            |      |      |

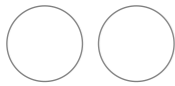

JOB NUMBER  
PART NUMBER



Max rated output: 20A, 250V~, 50Hz

USB input (if fitted): 0.8 - 1.0A  
max output 1: 5V/3A  
max output 2: 5V/2.4A  
power supply is only suitable for IT equipment

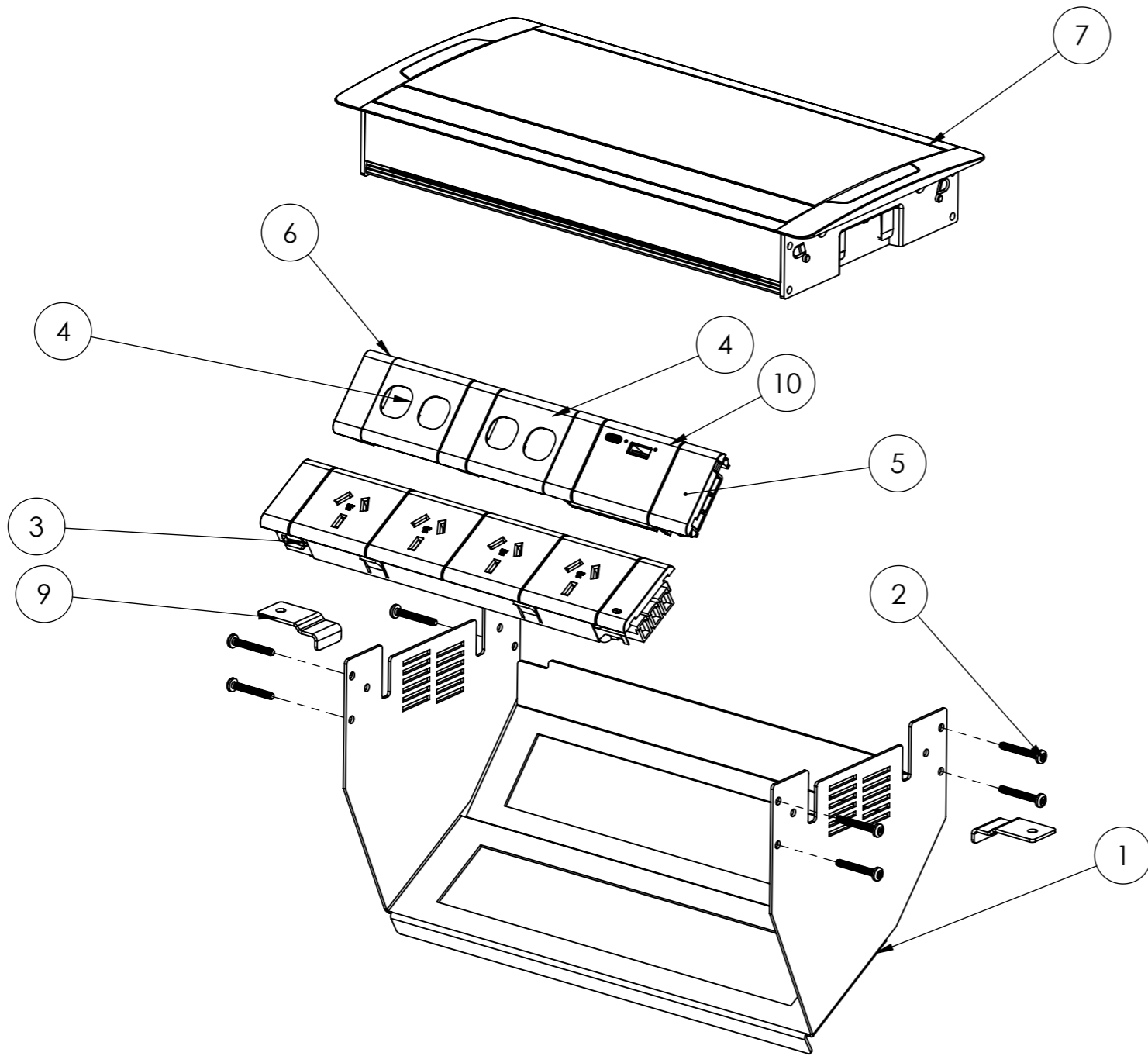

SUGGESTED WIRING:

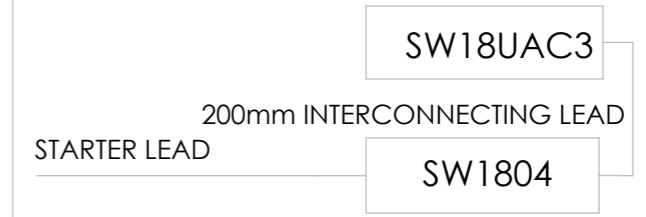

| ITEM NO. | PART NUMBER                | DESCRIPTION                         | QTY. |
|----------|----------------------------|-------------------------------------|------|
| 1        | LU1735                     | AFS0405 MKII undercarriage          | 1    |
| 2        | -                          | 6G x 1" Pan Head Self Tapping Screw | 8    |
| 3        | SW1804                     | QUAD AUTO SWITCHED POWER MODULE     | 1    |
| 4        | SW18C-2                    | 50mm DUAL DATA TILE                 | 2    |
| 5        | SW18B                      | 25mm blank tile                     | 1    |
| 6        | SW18A                      | 18mm blank tile                     | 2    |
| 7        | ACH295                     | ACCEDE BASIC MODEL LID ASSEMBLY     | 1    |
| 8        | 200mm INTERCONNECTING LEAD | 200mm L3 INTERCONNECTING LEAD       | 1    |
| 9        | 95607                      | AF FIXING BRACKET                   | 2    |
| 10       | LU19709                    | 30W USB AC CHARGER                  | 1    |

|  |  |   |  |   |  |                            |  |
|--|--|---|--|---|--|----------------------------|--|
| <b>MATERIAL:</b><br>ALUMINIUM / POLYCARBONATE  |  | <b>TOLERANCES UNLESS OTHERWISE STATED:</b><br>X ±0.5<br>X.X ±0.2<br>X.XX ±0.1<br>X.XXX ±0.05<br>ANG ±0.5° |  |  <b>CMS Electracom</b> |  | COPYRIGHT © 2015           |  |
| <b>FINISH:</b><br>ANODISED / FINE EDM  |  | <b>COLOUR:</b><br>VARIOUS / SILVER  |  | <b>TITLE:</b><br>ACCEDE WITH SW1804 + SW18UAC3 + 4 DATA   |  |                            |  |
| THIS DRAWING & ASSOCIATED CAD FILES ARE ISSUED IN THE STRICTEST CONFIDENCE AND ARE ONLY TO BE USED IN THE COMMERCIAL INTERESTS OF CMS ELECTRACOM PTY LTD |  |   |  | DRAWN IN mm TO AS1100 DO NOT SCALE  |  | <b>DRAWING:</b><br>LU39377 |  |
|  |  |   |  | <b>REV:</b><br>2  |  | <b>A3</b>                  |  |
|  |  |   |  | SCALE 1:3   |  | SHEET 2 OF 2               |  |