





CUSTOMER SIGNATURE:		TOLERANCES UNLESS OTHERWISE STATED: X ±0.5 X.X ±0.2 X.XX ±0.1 X.XXX ±0.05 ANG ±0.5°	 CMS Electracom <small>COPYRIGHT © 2020</small>	
MATERIAL:			TITLE: CENTURY CT02UC + FT2LIDSC	
FINISH:			DRAWING: LU48982	
COLOUR:			REV: 1	
SS / MS		DRAWN IN mm TO AS1100 DO NOT SCALE 	A3	
BRUSHED / POWDERCOATED			SCALE 1:3 SHEET 1 OF 2	
BLACK SATIN		THIS DRAWING & ASSOCIATED CAD FILES ARE ISSUED IN THE STRICTEST CONFIDENCE AND ARE ONLY TO BE USED IN THE COMMERCIAL INTERESTS OF CMS ELECTRACOM PTY LTD		

1	RELEASED FOR PRODUCTION	13/08/2025	SP	AP
REV	DESCRIPTION	DATE	DRWN	APPV
REVISIONS				

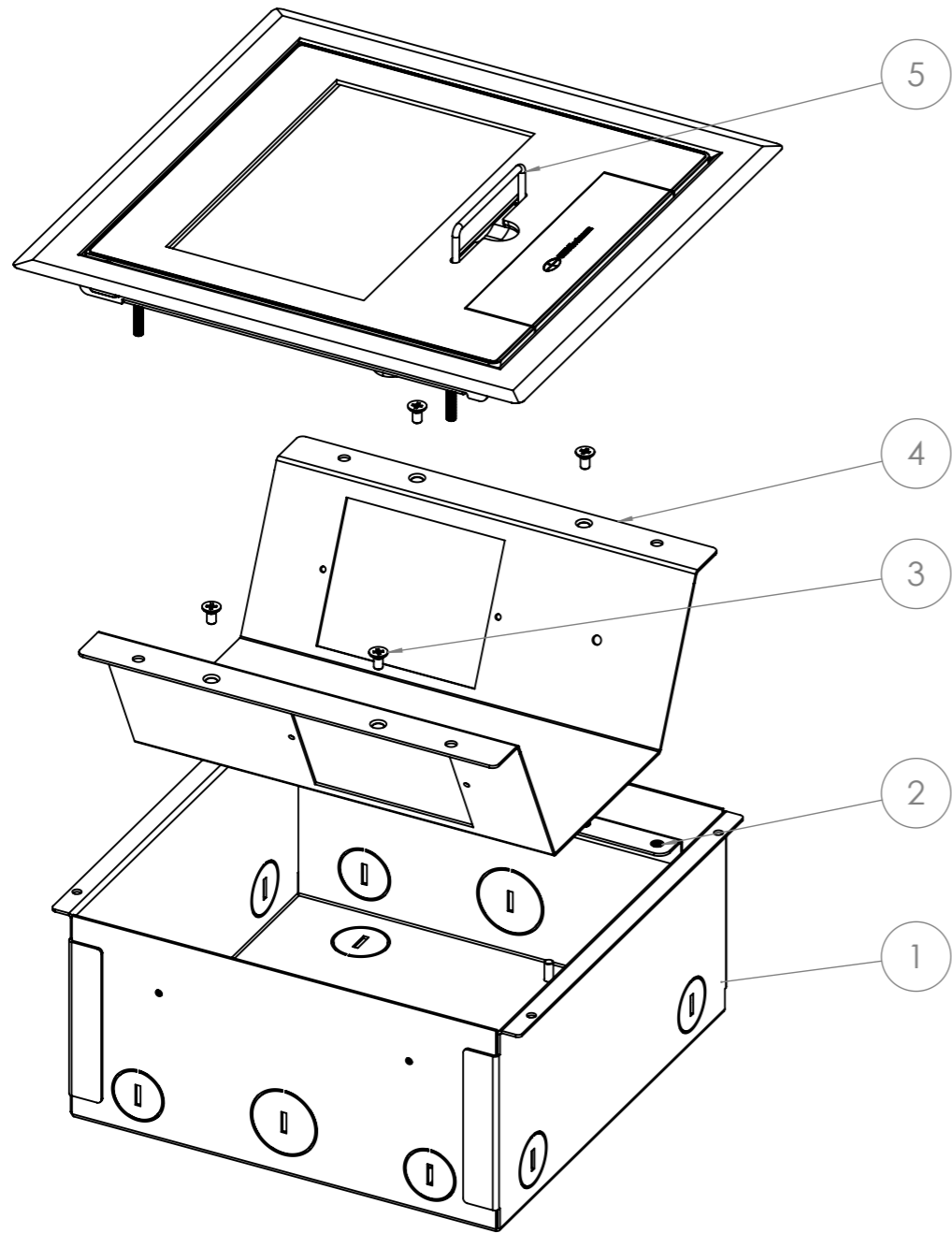

ITEM NO.	Part No	DESCRIPTION	QTY.
1	LU20287	FB UNDERCARRIAGE TO SUIT CLIPSAL PLATES	1
2	LU20290	FB SMALL SUPPORT PLATE	2
3	7012410	M4 x 10 CSK Machine Screw	4
4	LU20288	FB plate to suit 2 x clipsal 2000 series	1
5	LU11689-CA	LID+FRAME ASSEMBLY STAINLESS SOFT-CLOSE FB2	1

CUSTOMER SIGNATURE:	TOLERANCES UNLESS OTHERWISE STATED: X ±0.5 X.X ±0.2 X.XX ±0.1 X.XXX ±0.05 ANG ±0.5°	 CMS Electracom <small>COPYRIGHT © 2020</small>		
MATERIAL: SS / MS				TITLE: CENTURY CT02UC + FT2LIDSC
FINISH: BRUSHED / POWDERCOATED		DRAWING: LU48982		REV: 1
COLOUR: BLACK SATIN		SCALE 1:4		A3
<small>THIS DRAWING & ASSOCIATED CAD FILES ARE ISSUED IN THE STRICTEST CONFIDENCE AND ARE ONLY TO BE USED IN THE COMMERCIAL INTERESTS OF CMS ELECTRACOM PTY LTD</small>		<small>DRAWN IN mm TO AS1100 DO NOT SCALE</small> 		
		SHEET 2 OF 2		