

140W DC USB AC
MODUAL = U

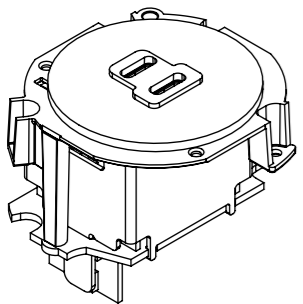

140W DC USB CC
MODUAL = UC

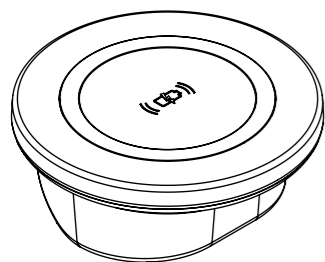

HELIPAD (15W) MAGNETIC
WIRELESS CHARGER= I

**FACTORY ONLY INSERTABLE MODULES
REFER PAGE 2 FOR MODULE
CONFIGURATION**

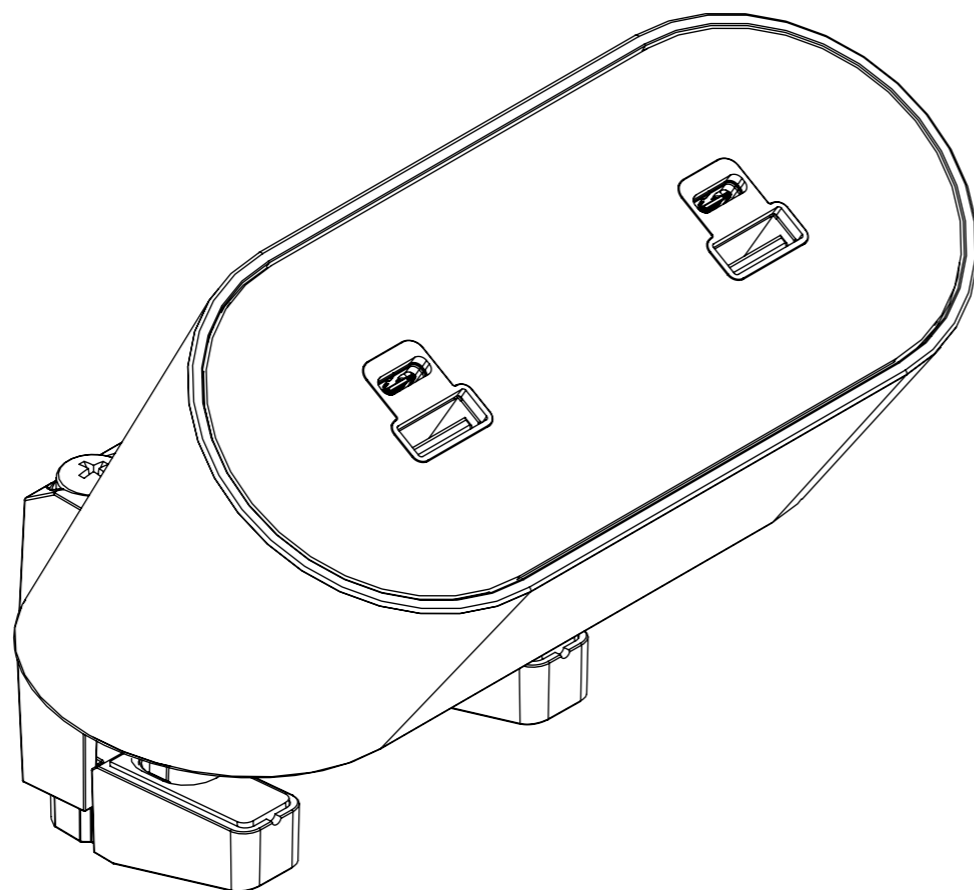

ABOVE DESK CLAMP

MIN TABLE THICKNESS: 20MM
MAX TABLE THICKNESS 32MM

NOTE:
TABLE SCALLOP OF **40mm MINIMUM
REQUIRED** WHEN USING HELISTAND &
PRIVACY SCREEN TO ALLOS
ADDITIONAL SPACE FOR LARG
PHONES

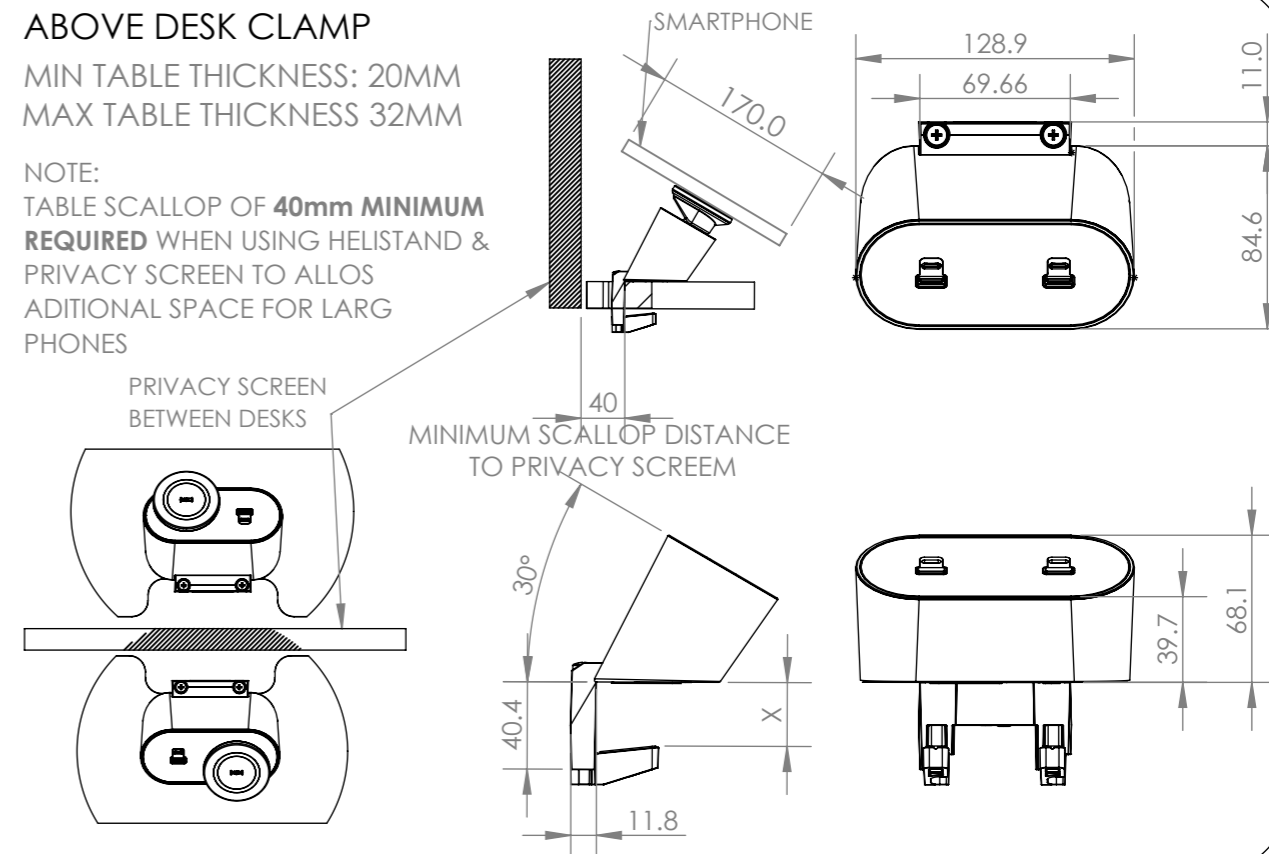

UNDER DESK CLAMP

COMPATIBLE MOUNTING
SCREWS: 4G, 6G

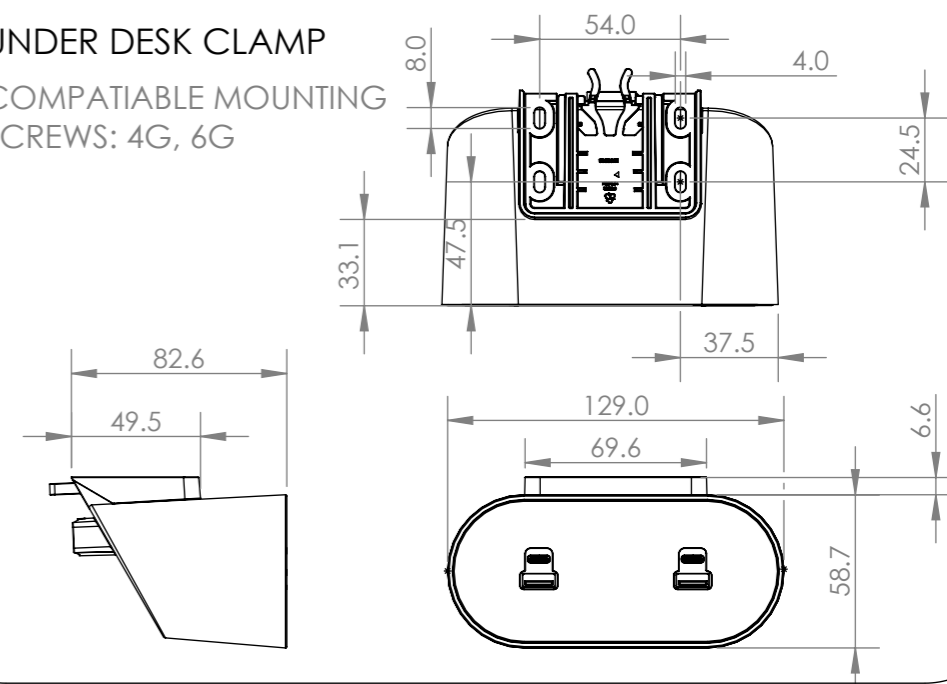

REV	DESCRIPTION	DATE	DRWN	APPV
4	140W C+C CONFIGURATIONS ADDED	6/8/2025	JB	RG
3	PCB TRIM DETAILS ADDED	2/7/2024	JB	RG
2	RELEASED FOR PRODUCTION	13/6/2025	JB	RG
1	RELEASED FOR EVALUATION - NOT FOR PRODUCTION	7/11/2024	JB	RG
REVISIONS				

CUSTOMER SIGNATURE:	
MATERIAL:	PC FR
FINISH:	FINE EDM / POLISHED / FABRIC
COLOUR:	REFER TABLE
THIS DRAWING & ASSOCIATED CAD FILES ARE ISSUED IN THE STRICTEST CONFIDENCE AND ARE ONLY TO BE USED IN THE COMMERCIAL INTERESTS OF CMS ELECTRACOM PTY LTD	

TOLERANCES UNLESS OTHERWISE STATED:

- X ±0.5
- X.X ±0.2
- X.XX ±0.1
- X.XXX ±0.05
- ANG ±0.5°

DRAWN IN mm TO AS1100 DO NOT SCALE



TITLE:
NOVA DUO XL DC CONFIGURATIONS

DRAWING: LU45421 **REV:** 4 **A3**

SCALE 1:2

SHEET 1 OF 7

NOTE:

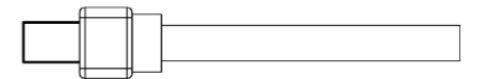

CABLE TYPE: 2 CORE x 2.5mm²
 DESCRIPTION: XT60 MALE CONNECTOR LEAD
 COLOUR: BLACK
 (REFER TO PURCHASE ORDER)
 LENGTH (mm):

xx	LENGTH (mm)
05	500
09	900

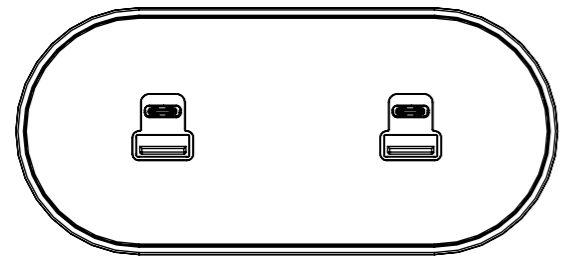

FRND*UUXxxXX

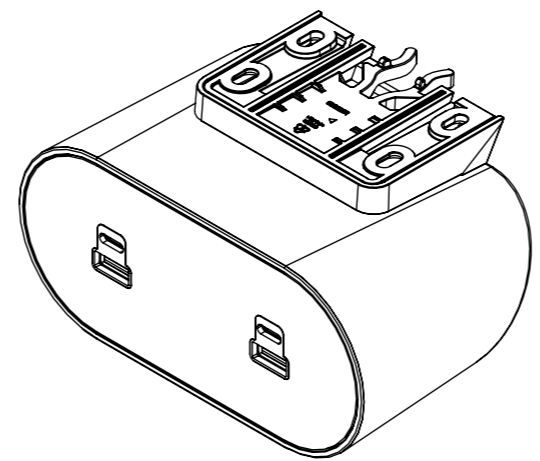

Z = UNDER DESK CLAMP

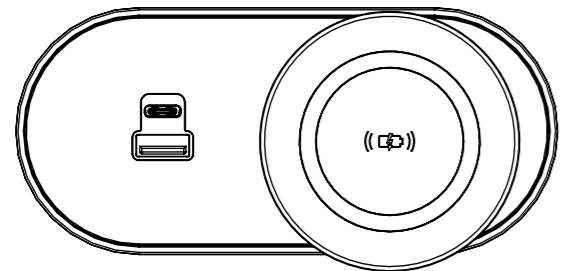

FRND*UIXxxXX

ONLY AVAILABLE IN ABOVE DESK CLAMP

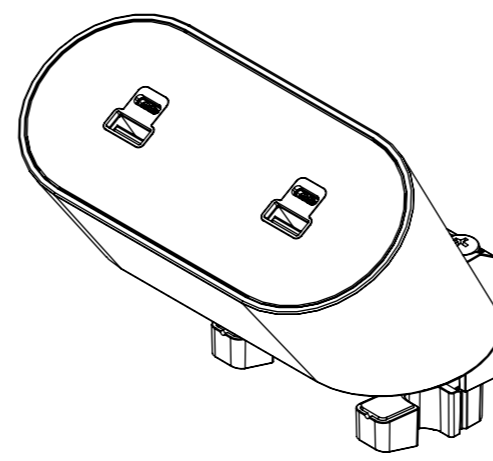

S= ABOVE DESK CLAMP

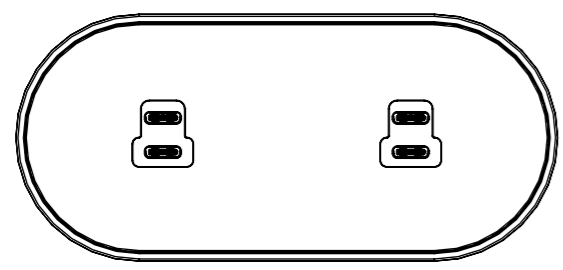

FRND*UCUCXxxXX

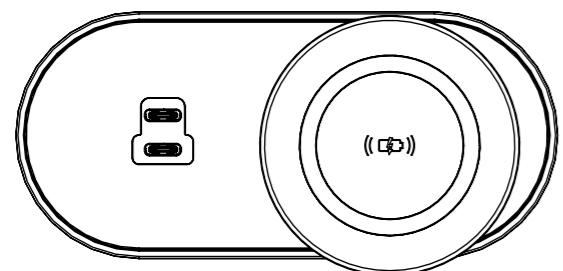

FRND*UCIXxxXX

ONLY AVAILABLE IN ABOVE DESK CLAMP

COLOUR VARIATIONS	
PART NUMBER	DESCRIPTION
W	WHITE BODY & CLAMP
B	BLACK BODY & CLAMP
1	WHITE DECAL GLOSS
2	WHITE DECAL MATT
3	BLACK DECAL GLOSS
4	BLACK DECAL MATT
FABRIC FINISH REFER TO LU41144	
A	FABRIC COLOUR 1 - VANILA
B	FABRIC COLOUR 2 - SMOKE
C	FABRIC COLOUR 3 - IRON FORMERLY KNOWN AS CHARCOAL
D	FABRIC COLOUR 4 - CHARCOAL FORMERLY KNOWN AS BLACK

PART NUMBER: (REFER CONFIGURATION)XxxXX
 NOTE - * - CLAMP TYPE - (S = ABOVE DESK OR Z = UNDER DESK)
 X - LEAD TYPE (XT60 PLUG = M)
 xx - LENGTH - 05 / 09
 XX - COLOUR - W / B + 1 / 2 / 3 / 4 + (OPTIONAL) A / B / C / D

CUSTOMER SIGNATURE:	TOLERANCES UNLESS OTHERWISE STATED: X ±0.5 X.X ±0.2 X.XX ±0.1 X.XXX ±0.05 ANG ±0.5°
MATERIAL: PC FR	
FINISH: FINE EDM / POLISHED / FABRIC	
COLOUR: REFER TABLE	
THIS DRAWING & ASSOCIATED CAD FILES ARE ISSUED IN THE STRICTEST CONFIDENCE AND ARE ONLY TO BE USED IN THE COMMERCIAL INTERESTS OF CMS ELECTRACOM PTY LTD	
DRAWN IN mm TO AS1100 DO NOT SCALE	



TITLE: NOVA DUO XL DC CONFIGURATIONS		
DRAWING: LU45421	REV: 4	A3
SCALE 1:2	SHEET 2 OF 7	