

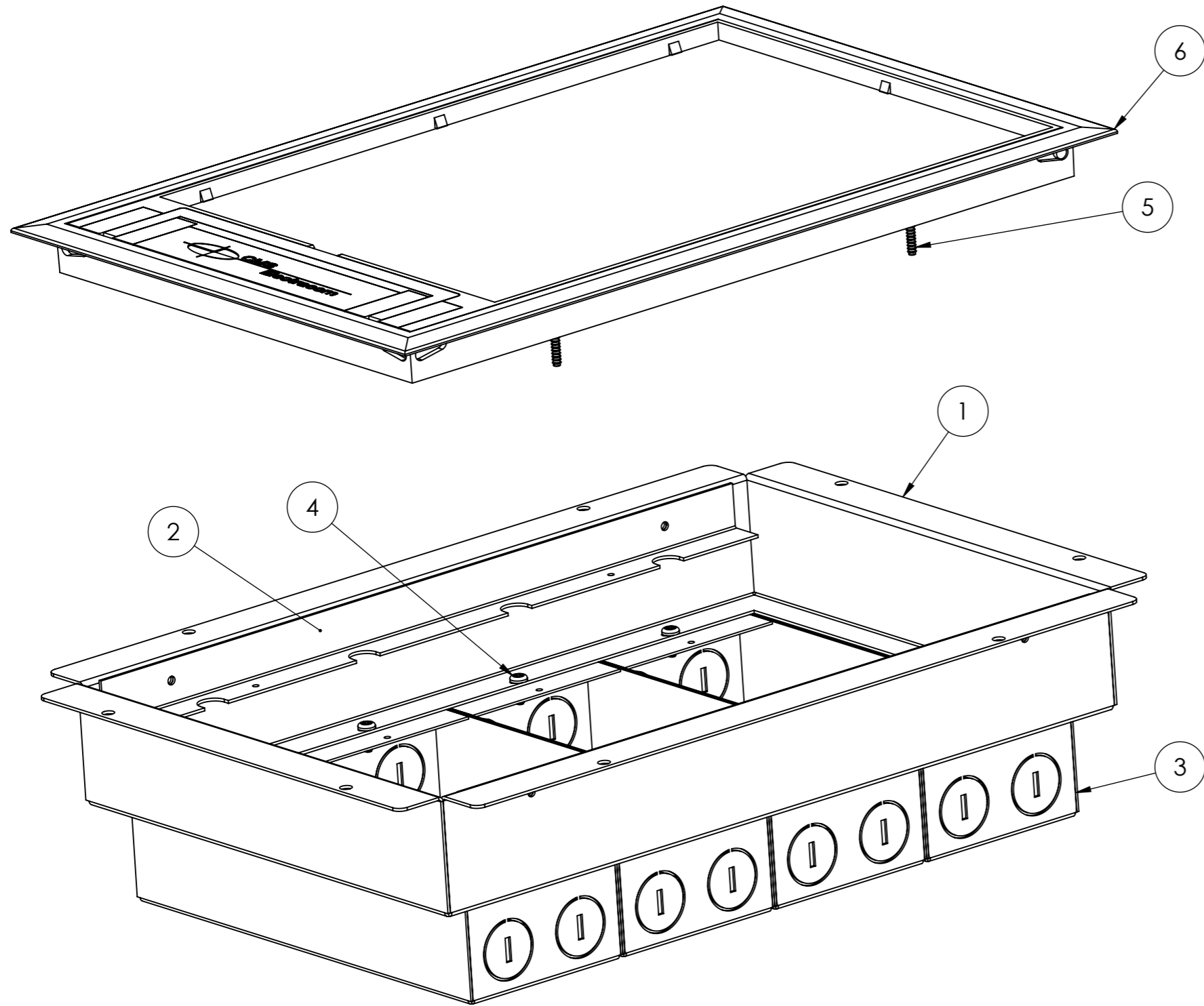

REVISION HISTORY		UNLESS OTHERWISE SPECIFIED: DIMENSIONS ARE IN MILLIMETERS		DO NOT SCALE DRAWING		REVISION 3	
DATE	MODIFICATIONS	TOLERANCES					
23/08/11	ISSUED FOR MANUFACTURING	0.00 ± 0.02	ANGULAR ± 0.5°				
19/12/11	CHANGED SUPPORT BRACKETS	0.0 ± 0.1		TITLE: FL4090			
07/05/13	MODIFIED CHASSIS	0 ± 0.5					
		DEBUR AND BREAK SHARP EDGES		DWG NO. LU-2414			
		THE MATERIAL CONTAINED HEREIN IS THE SOLE PROPERTY OF CMS ELECTRACOM. ANY UNAUTHORIZED REPRODUCTIONS, MODIFICATIONS AND / OR DISTRIBUTION IS STRICTLY PROHIBITED.					
		NAME	DATE	PART NO. TBC			
		LUCKY	07/05/13				
		MATERIAL:	X	SCALE NTS SHEET 1 OF 2			
		FINISH:	X				
		FILE ON SHARED\CAD:		A3			
		H:\Melbourne\CAD\Current Production Drawings					
		FILE ON NAS:					
		Z:\Work files\Floor boxes\VL\FL4					



ITEM NO.	PART NUMBER	QTY.
1	LU2415_V2_CMS Floor box CL90 large undercarriage	1
2	LU2878_V1_FB4 support bracket	2
3	LU1408_V5_Accessories box extended	4
4	6G x 3/8" pan head screw	8
5	6G x 3/4" blind pan head screw	4
6	Apollo FB4 lid	1

REVISION HISTORY		UNLESS OTHERWISE SPECIFIED: DIMENSIONS ARE IN MILLIMETERS		DO NOT SCALE DRAWING		REVISION 3	
DATE	MODIFICATIONS	TOLERANCES					
23/08/11	ISSUED FOR MANUFACTURING	0.00 ± 0.02	ANGULAR ± 0.5°				
19/12/11	CHANGED SUPPORT BRACKETS	0.0 ± 0.1		TITLE: FL4090			
07/05/13	MODIFIED CHASSIS	0 ± 0.5					
		DEBUR AND BREAK SHARP EDGES		DWG NO.		LU-2414	
		THE MATERIAL CONTAINED HEREIN IS THE SOLE PROPERTY OF CMS ELECTRACOM. ANY UNAUTHORIZED REPRODUCTIONS, MODIFICATIONS AND / OR DISTRIBUTION IS STRICTLY PROHIBITED.		PART NO.		TBC	
		NAME	DATE	SCALE		NTS SHEET 2 OF 2	
		LUCKY	07/05/13				
		MATERIAL:	X				
		FINISH:	X				
		FILE ON SHARED\CAD:					A3
		FILE ON NAS:					
		Z:\Work files\Floor boxes\VL\VL4					