

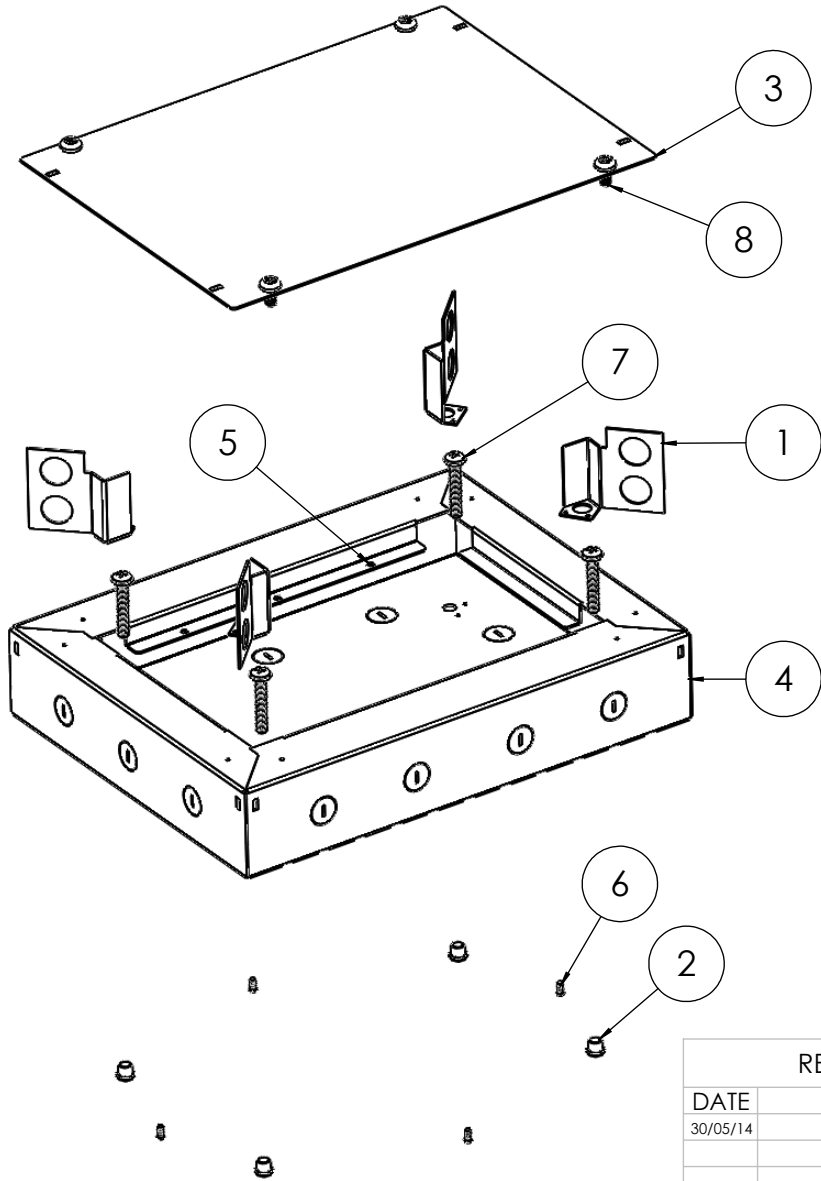

REVISION HISTORY		UNLESS OTHERWISE SPECIFIED: DIMENSIONS ARE IN MILLIMETERS		DO NOT SCALE DRAWING	REVISION 1
DATE	MODIFICATIONS	TOLERANCES			
30/05/14	ISSUED FOR EVALUATION	0.00 ± 0.02	ANGULAR ± 0.5°		
		0.0 ± 0.1		TITLE: FT4CH80	
		0 ± 0.5			
		DEBUR AND BREAK SHARP EDGES		DWG NO. LU6604	
		THE MATERIAL CONTAINED HEREIN IS THE SOLE PROPERTY OF CMS ELECTRACOM. ANY UNAUTHORIZED REPRODUCTIONS, MODIFICATIONS AND / OR DISTRIBUTION IS STRICTLY PROHIBITED.			
		NAME	DATE	PART NO. TBC	
		LUCKY	30/05/14		
		MATERIAL:	1.6mm Steel	SCALE NTS SHEET 1 OF 2	
		FINISH:	Galvanized		
		FILE ON SHARED\CAD:	H:\Melbourne\CAD\Current Production Drawings	A4	
		FILE ON NAS:	Z:\Work files\Floor boxes\Titan		



ITEM NO.	PART NUMBER	QTY.
1	LU3341_V1_Titan floor box low profile segregation plate	4
2	M8 nut-sert	4
3	LU2479_V3_SC box chassis cover plate	1
4	LU3329_V8_Titan FB4 floor box low profile screed box	1
5	PEM M4 clinch nut	6
6	M4 x 10 flush head threaded stud	4
7	M8 x 50 pan head machine screw	4
8	8G x 3-4 pan head tapping screw	4

REVISION HISTORY		UNLESS OTHERWISE SPECIFIED: DIMENSIONS ARE IN MILLIMETERS		DO NOT SCALE DRAWING		REVISION 1	
DATE	MODIFICATIONS	TOLERANCES					
30/05/14	ISSUED FOR EVALUATION	0.00 ± 0.02	ANGULAR ± 0.5°				
		0.0 ± 0.1		TITLE: FT4CH80			
		0 ± 0.5					
		DEBUR AND BREAK SHARP EDGES		DWG NO. LU6604			
		THE MATERIAL CONTAINED HEREIN IS THE SOLE PROPERTY OF CMS ELECTRACOM. ANY UNAUTHORIZED REPRODUCTIONS, MODIFICATIONS AND / OR DISTRIBUTION IS STRICTLY PROHIBITED.					
		NAME	DATE	PART NO. TBC			
		LUCKY	30/05/14				
		MATERIAL: 1.6mm Steel		SCALE NTS SHEET 2 OF 2			
		FINISH: Galvanized					
		FILE ON SHARED\CAD:		A4			
		H:\Melbourne\CAD\Current Production Drawings					
		FILE ON NAS:					
		Z:\Work files\Floor boxes\Titan					