

FRONT VIEW

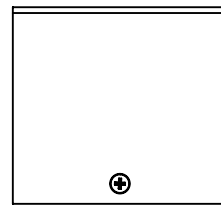

END VIEW

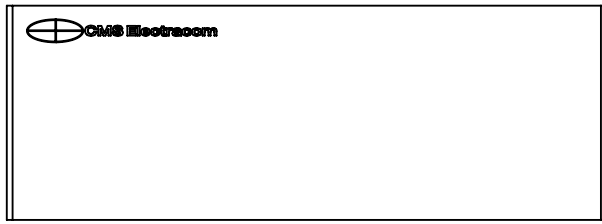

TOP VIEW

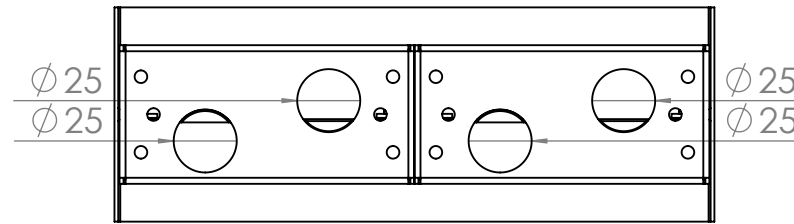

BOTTOM VIEW

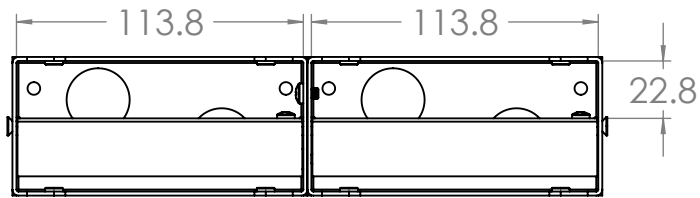

INTERNAL VIEW

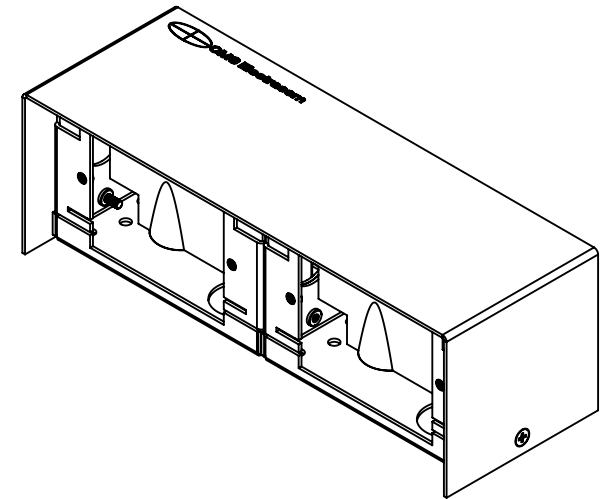

REVISION HISTORY		UNLESS OTHERWISE SPECIFIED: DIMENSIONS ARE IN MILLIMETERS		DO NOT SCALE DRAWING		REVISION 1	
DATE	MODIFICATIONS	TOLERANCES					
14/03/13	ISSUED FOR MANUFACTURING	0.00 ± 0.02	ANGULAR ± 0.5°				
		0.0 ± 0.1		TITLE: <h1 style="text-align: center;">G2</h1>			
		0 ± 0.5					
		DIMENSIONS IN AN OBOUND ARE CRITICAL & MUST BE CHECKED		DWG NO. LU-4832			
		THE MATERIAL CONTAINED HEREIN IS THE SOLE PROPERTY OF CMS ELECTRACOM. ANY UNAUTHORIZED REPRODUCTIONS, MODIFICATIONS AND / OR DISTRIBUTION IS STRICTLY PROHIBITED.					
		NAME	DATE	DRAWN BY		A4	
		LUCKY	14/03/13	X			
		MATERIAL:	X	PART NO.		X	
		FINISH:	X	X			
		FILE ON SHARED\CAD:	H:\Melbourne\CAD\Current Production Drawings	SCALE		SHEET 1 OF 2	
		FILE ON NAS:	Z:\Work files\Floor boxes\G2	1:2			

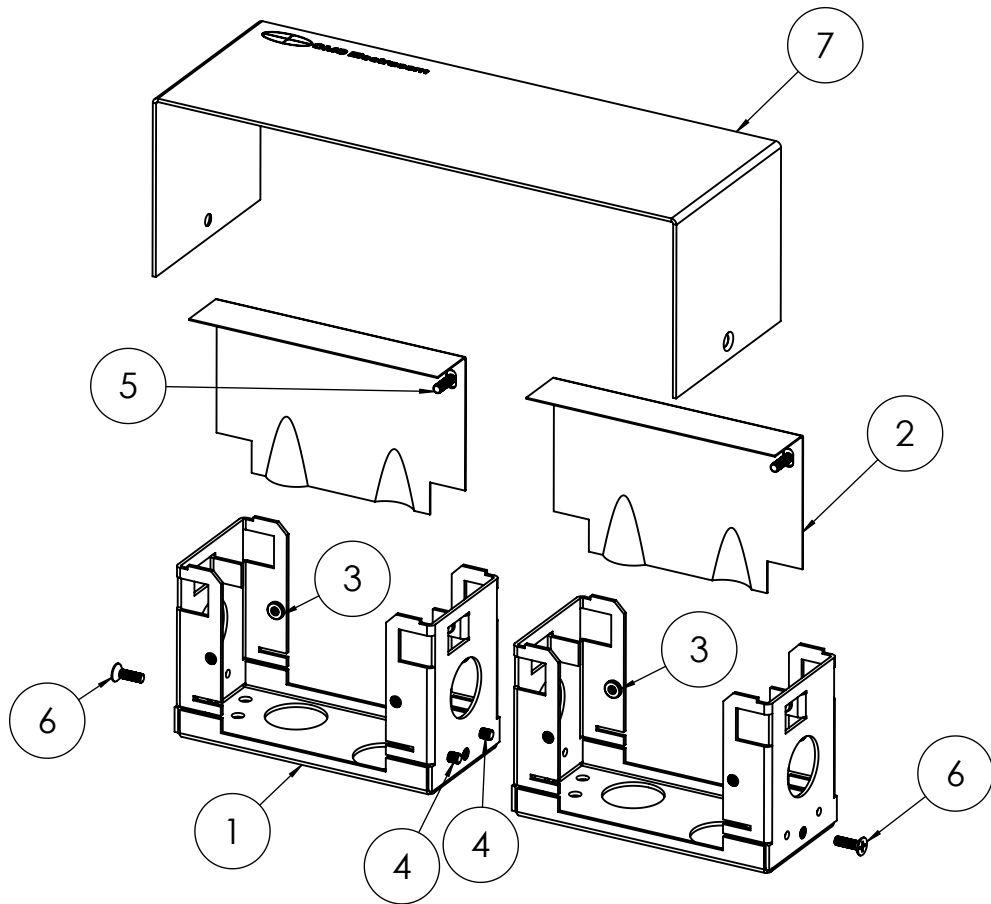

ITEM NO.	PART NUMBER	QTY.
1	LU4707_V2_G1 frame MKII	2
2	LU4708_V2_G1 divider MKII	2
3	PEM M3.5 clinch nut	14
4	M4 x 6 pan head machine screw	2
5	M3.5 x 12 pan head machine screw	2
6	M3.5 x 12 CSK machine screw STAINLESS STEEL	2
7	LU4833_V1_G2 external housing	1

REVISION HISTORY		UNLESS OTHERWISE SPECIFIED: DIMENSIONS ARE IN MILLIMETERS		DO NOT SCALE DRAWING		REVISION 1			
DATE	MODIFICATIONS	TOLERANCES							
14/03/13	ISSUED FOR MANUFACTURING	0.00 ± 0.02	ANGULAR ± 0.5°						
		0.0 ± 0.1		TITLE: <div style="text-align: center; font-size: 24px;">G2</div>					
		0 ± 0.5							
		DIMENSIONS IN AN OBOUND ARE CRITICAL & MUST BE CHECKED		DWG NO.		DRAWN BY			
		THE MATERIAL CONTAINED HEREIN IS THE SOLE PROPERTY OF CMS ELECTRACOM. ANY UNAUTHORIZED REPRODUCTIONS, MODIFICATIONS AND / OR DISTRIBUTION IS STRICTLY PROHIBITED.		LU-4832		X			
				PART NO.		X		A4	
				FILE ON SHARED\CAD:		X			
				FILE ON NAS:		NTS		X	
		Z:\Work files\Floor boxes\G2		SCALE		SHEET 2 OF 2			