

TITAN FTA2

LID: ABS Plastic with recess provision for carpet tile

UNDERCARRIAGE: Access Floor Assembly - 95mm Depth

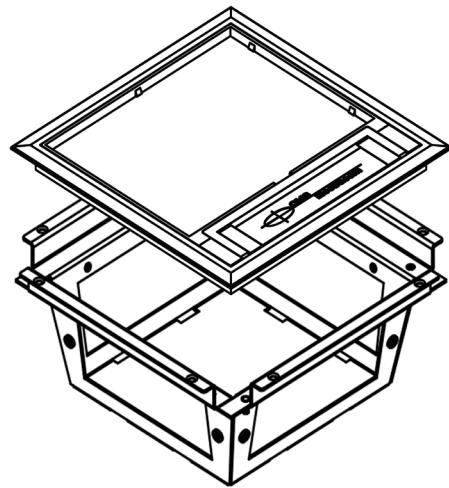

Lid Features

- Carpet frame with recessed lid manufactured from ABS plastic.
- 7mm lid recess for carpet or vinyl tile.
- Easy-grab handle and functional cable exit when lid closed.
- Lock option available for security applications.

Undercarriage Features

- Designed for AV Integration with Interchangeable mounting plates for Crestron, Extron, Kramer and AMX adapters.
- Wide range of modular soft/hardwired power, data and AV mounting plates.
- CAT6, 6A and 7 Compliant.
- Custom brackets & plates available.
- Designed and manufactured in Australia.

Technical Specification

Floor application	Access raised floor
Cut-out dimension	L210mm x W210mm x D95mm
Lid recess dimension	L148mm x W191mm x D7mm
Lid specification	ABS plastic with recess provision for carpet tile.
Undercarriage and screed box specification	Undercarriage manufactured from black powder-coated mild steel.
Weight rating	120kg

TITAN FTA2

Component List

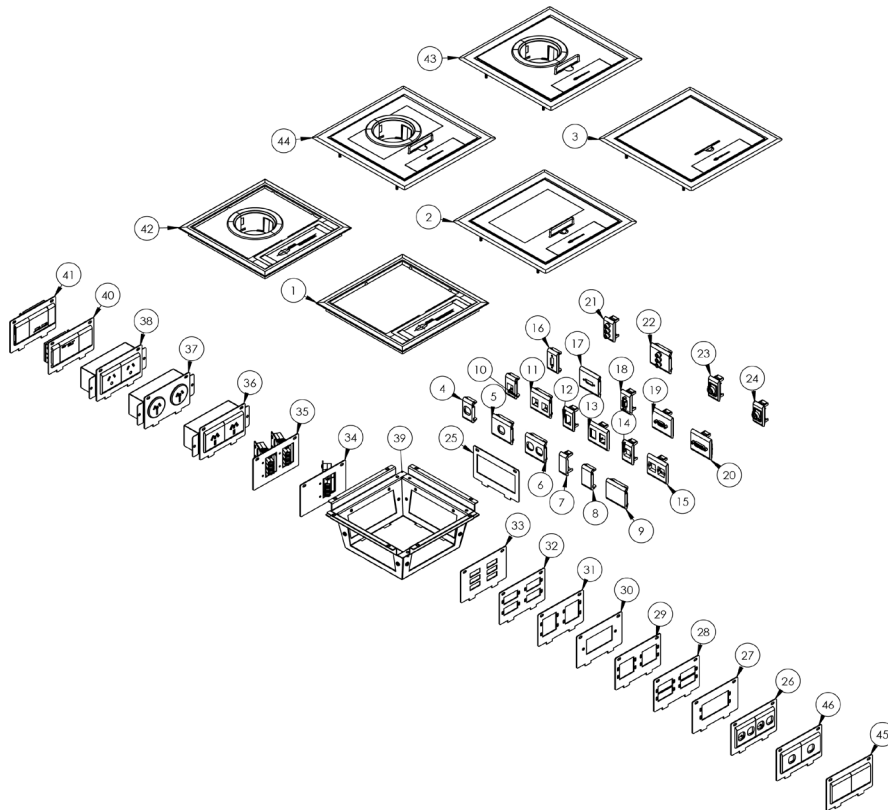

No.	Part No & Description	No.	Part No & Description
1	F2LID - APOLLO FLOORBOX PLASTIC LID	17	SW18CDP1 - 50mm TILE WITH PROVISION FOR DISPLAY PORT
2	FT2LIDSC - STAINLESS SOFT-CLOSE FB2 RECESSED LID	18	SW18BVV - 25mm TILE F/W VGA MINI GENDER BENDER
3	FTF2LIDSC - STAINLESS SOFT-CLOSE FB2 FLUSH LID	19	SW18CVV - 50mm TILE F/W VGA MINI GENDER BENDER
4	SW18B1 - 25mm SINGLE DATA TILE	20	SW18CDVI - 50mm DATA TILE - F/W DVI FEMALE CONNECTOR
5	SW18C1 - 50mm SINGLE DATA TILE	21	
6	SW18C2 - 50mm DUAL DATA TILE	22	
7	SW18A - 18mm blank tile	23	SW18BX3 - 25mm TILE F/W MINI XLR 3 PIN PLUG WITH SOLDER CUPS
8	SW18B - 25mm blank tile	24	SW18BX4 - 25mm TILE F/W MINI XLR 4 PIN PLUG WITH SOLDER CUPS
9	SW18C - 50mm BLANK TILE	25	FTBPP - TITAN 100mm BLANK PLATE
10	SW18B1K - 25mm SINGLE TILE TO SUIT KEYSTONE DATA	26	FTD4 - ADAPTER PLATE TO SUIT 2 x 50mm DUAL TILE (PROVISION 4 x DATA)
11	SW18C2K - 50mm DUAL DATA TILE TO SUIT KEYSTONE JACKS	27	FTEXAAP - AAP EXTRON ADAPTER PLATE TO SUIT 1 x DOUBLE OR 2 x SINGLE MODULES
12	SW18B1SE - 25mm SINGLE TILE TO SUIT SIEMON DATA	28	FTEXMAAP4 - TITAN FLOOR BOX MAAP EXTRON ADAPTER PLATE QUAD
13	SW18C2SE - 50mm DUAL DATA TILE TO SUIT SIEMON JACKS	29	FTKRWD2 - TITAN FLOOR BOX KRAMER ADAPTER TO SUIT "W" xx DOUBLE MODULES
14	SW18B1SM - 25mm SINGLE TILE TO SUIT SYSTIMAX DATA	30	FTKRVS - KRAMER ADAPTER PLATE TO SUIT "SV" xx MODULES
15	SW18C2SM - 50mm DUAL DATA TILE TO SUIT SYSTIMAX DATA	31	FTEXMAAPD2 - TITAN FLOOR BOX MAAP EXTRON ADAPTER PLATE DOUBLE
16	SW18BDP1 - 25mm TILE WITH PROVISION FOR DISPLAY PORT	32	FTKRW4 - TITAN FLOOR BOX KRAMER ADAPTER PLATE TO SUIT "W" xx QUAD MODULES

TITAN FTA2

Component List

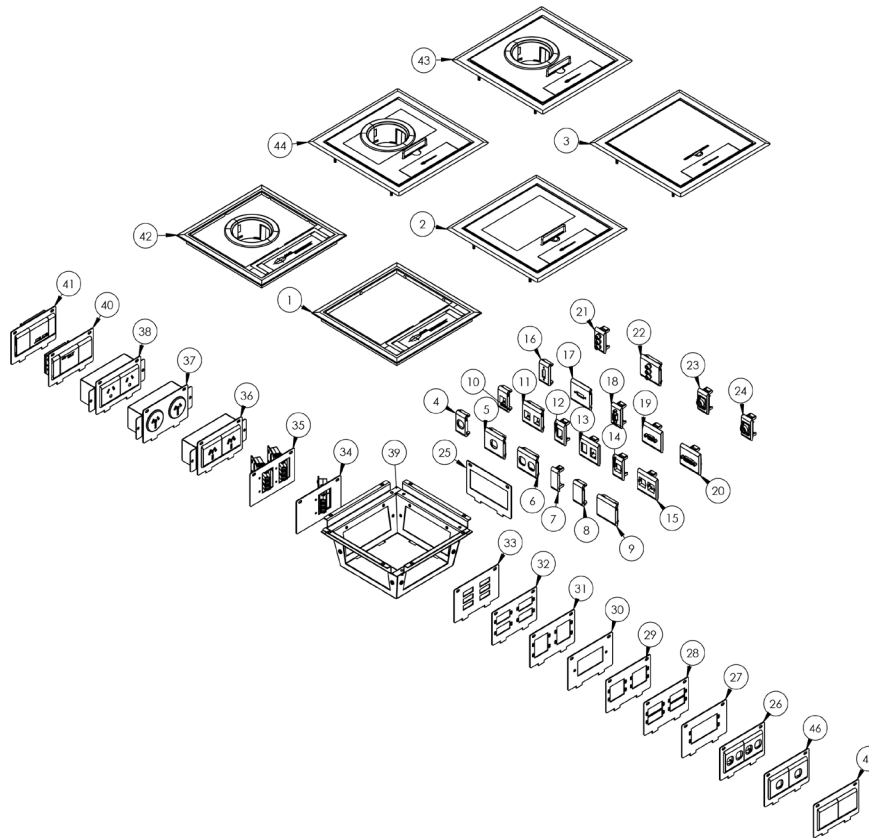

No.	Part No & Description	No.	Part No & Description
33	FTSCD - SC DUPLEX PLATE	40	FTP2UACBK - TITAN FB PLATE F/W DUAL USB TYPE A&C QUALCOMM Q/CHARGER & BLANK
34	FTTAG - STARTER PLATE C/W REWIREABLE SOCKET	41	FTP2UBK - TITAN FB PLATE F/W DUAL USB A CHARGER & BLANK
35	FTTAG2 - DOUBLE STARTER FULL PLATE - REWIREABLE SOCKETS	42	FT2LIDGY-UMB - FLOORBOX LID WITH GALVANISED STEEL LID INSERT AND UMBILICAL GROMMET
36	FTAP2 - POWER PLATE F/W 2 x AUTO SWITCHED GPO WITH BACK BOX	43	FTF2LIDSC-UMB - 2 COMPARTMENT SS SOFT CLOSE FLUSH LID WITH UMBILICAL GROMMET
37	FTAP215A - TITAN PLATE TO SUIT 2 x ROUND 15A GPO WITH BACK BOX	44	FT2LIDSC-UMB - 2 COMPARTMENT SOFT CLOSE RECESSED LID - WITH UMBILICAL GROMMET
38	FTAP2RE - POWER PLATE F/W 2 x AUTO SWITCHED ROUND EARTH GPO WITH BACK BOX	45	FTBP - BLANK PLATE F/W 2 50mm BLANK TILES
39	FTA2UC - FTA2 ACCESS UNDERCARRIAGE	46	FTD2 - ADAPTER PLATE TO SUIT 2 x 50mm SINGLE TILE (PROVISION 2 x DATA)

TITAN FTA2

Technical Specification

CMS Titan FTA2 access floorbox lid and undercarriage assembly. Lid manufactured from ABS Plastic with recess provision for carpet tile. Undercarriage manufactured from black powder-coated mild steel. Load capacity: 120kg

ID No.	Part No. & Description
1	F2LID - APOLLO FLOORBOX PLASTIC LID
39	FTA2 UC - FTA2 ACCESS UNDERCARRIAGE

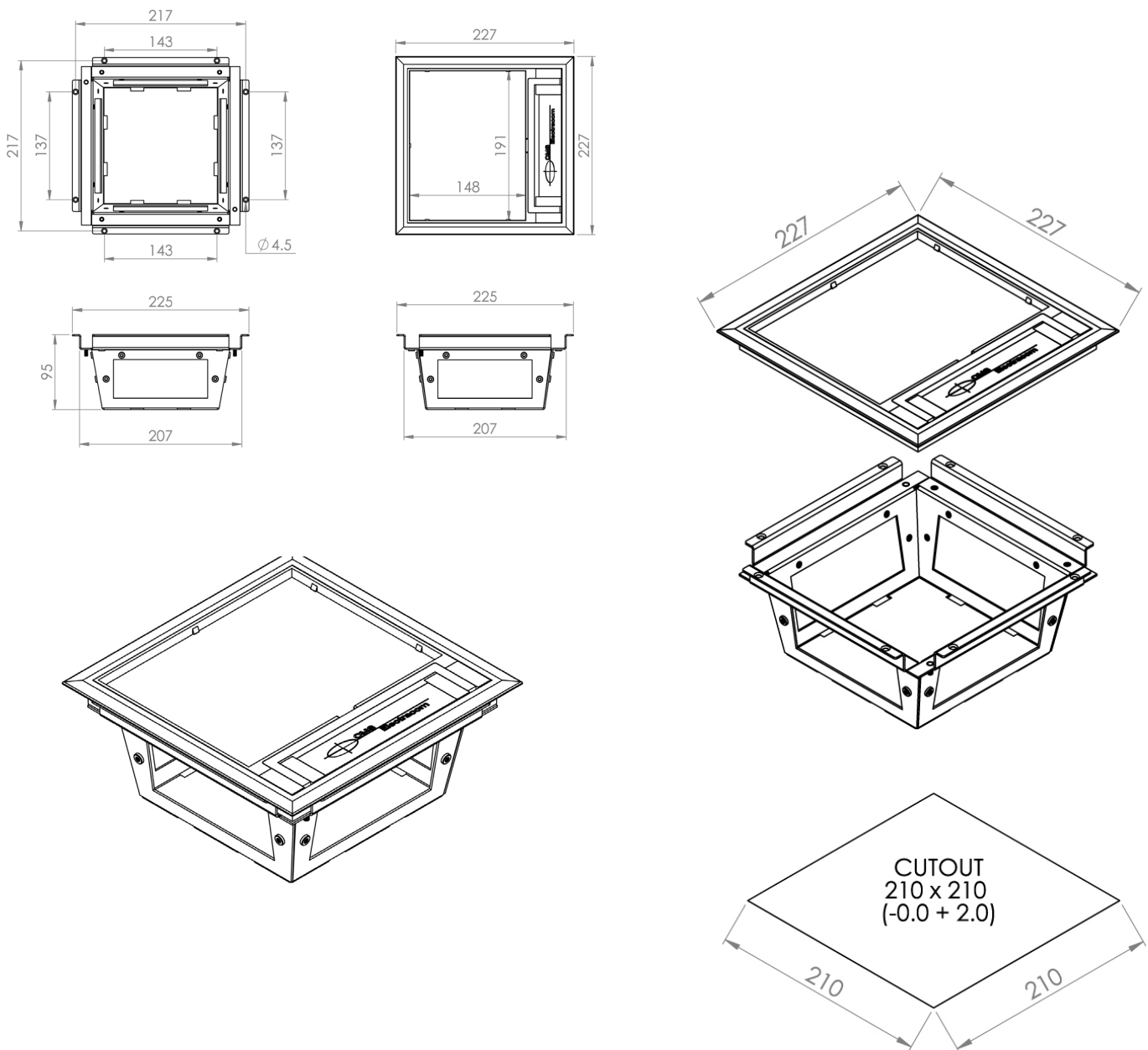

Disclaimer: CMS has made every attempt to ensure the accuracy and reliability of the information provided in this document are correct. All information contained in this document is to be used for general guidance only. CMS reserves the right to change, delete or modify the information without notice.

TITAN FTA2SC

LID: Stainless steel with recess provision for carpet tile

UNDERCARRIAGE: Access Floor Assembly - 95mm Depth

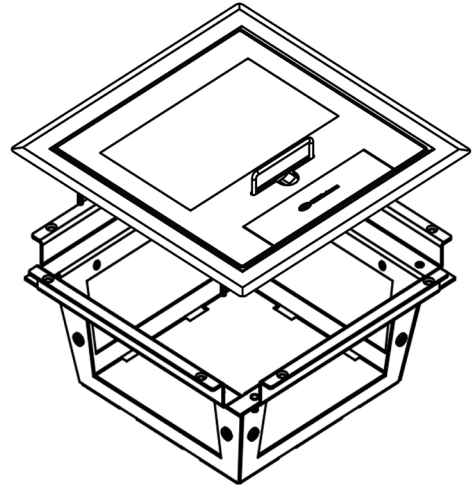

Lid Features

- Soft-closing lid with radius edges minimises risk of accidental impact and potential cable damage.
- 7mm lid recess for carpet tile insert.
- Easy-grab handle and functional cable exit when lid closed.
- Lock option available for security applications.

Undercarriage Features

- Designed for AV Integration with Interchangeable mounting plates for Crestron, Extron, Kramer and AMX adapters.
- Wide range of modular soft/hardwired power, data and AV mounting plates.
- Durable galvanised screed box supplied with cover.
- CAT6, 6A and 7 Compliant.
- Custom brackets & plates available.
- Designed and manufactured in Australia.

Technical Specification

Floor application	Access raised floor
Cut-out dimension	L210mm x W210mm x D95mm
Lid recess dimension	L95mm x W155mm x D7mm
Lid specification	Stainless steel with recess provision for carpet tile insert.
Undercarriage and screed box specification	Undercarriage manufactured from black powder-coated mild steel.
Weight rating	150kg

TITAN FTA2SC

Component List

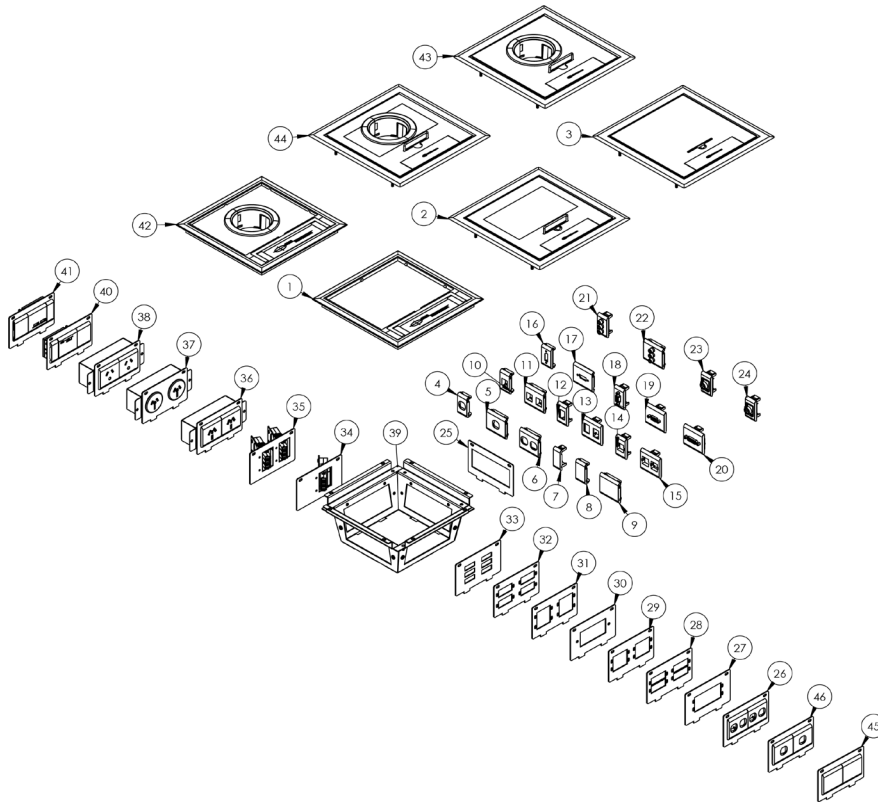

No.	Part No & Description	No.	Part No & Description
1	F2LID - APOLLO FLOORBOX PLASTIC LID	17	SW18CDP1 - 50mm TILE WITH PROVISION FOR DISPLAY PORT
2	FT2LIDSC - STAINLESS SOFT-CLOSE FB2 RECESSED LID	18	SW18BVV - 25mm TILE F/W VGA MINI GENDER BENDER
3	FTF2LIDSC - STAINLESS SOFT-CLOSE FB2 FLUSH LID	19	SW18CVV - 50mm TILE F/W VGA MINI GENDER BENDER
4	SW18B1 - 25mm SINGLE DATA TILE	20	SW18CDVI - 50mm DATA TILE - F/W DVI FEMALE CONNECTOR
5	SW18C1 - 50mm SINGLE DATA TILE	21	
6	SW18C2 - 50mm DUAL DATA TILE	22	
7	SW18A - 18mm blank tile	23	SW18BX3 - 25mm TILE F/W MINI XLR 3 PIN PLUG WITH SOLDER CUPS
8	SW18B - 25mm blank tile	24	SW18BX4 - 25mm TILE F/W MINI XLR 4 PIN PLUG WITH SOLDER CUPS
9	SW18C - 50mm BLANK TILE	25	FTBPP - TITAN 100mm BLANK PLATE
10	SW18B1K - 25mm SINGLE TILE TO SUIT KEYSTONE DATA	26	FTD4 - ADAPTER PLATE TO SUIT 2 x 50mm DUAL TILE (PROVISION 4 x DATA)
11	SW18C2K - 50mm DUAL DATA TILE TO SUIT KEYSTONE JACKS	27	FTEXAAP - AAP EXTRON ADAPTER PLATE TO SUIT 1 x DOUBLE OR 2 x SINGLE MODULES
12	SW18B1SE - 25mm SINGLE TILE TO SUIT SIEMON DATA	28	FTEXMAAP4 - TITAN FLOOR BOX MAAP EXTRON ADAPTER PLATE QUAD
13	SW18C2SE - 50mm DUAL DATA TILE TO SUIT SIEMON JACKS	29	FTKRWD2 - TITAN FLOOR BOX KRAMER ADAPTER TO SUIT "W" xx DOUBLE MODULES
14	SW18B1SM - 25mm SINGLE TILE TO SUIT SYSTIMAX DATA	30	FTKRVS - KRAMER ADAPTER PLATE TO SUIT "SV" xx MODULES
15	SW18C2SM - 50mm DUAL DATA TILE TO SUIT SYSTIMAX DATA	31	FTEXMAAPD2 - TITAN FLOOR BOX MAAP EXTRON ADAPTER PLATE DOUBLE
16	SW18BDP1 - 25mm TILE WITH PROVISION FOR DISPLAY PORT	32	FTKRW4 - TITAN FLOOR BOX KRAMER ADAPTER PLATE TO SUIT "W" xx QUAD MODULES

TITAN FTA2SC

Component List

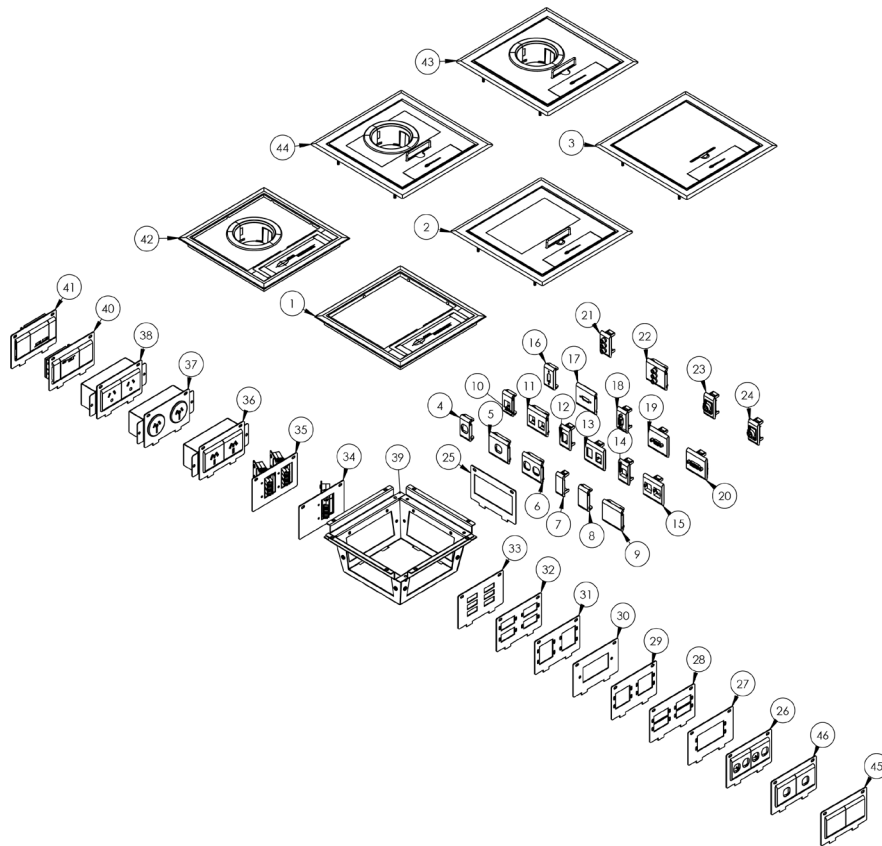

No.	Part No & Description	No.	Part No & Description
33	FTSCD - SC DUPLEX PLATE	40	FTP2UACBK - TITAN FB PLATE F/W DUAL USB TYPE A&C QUALCOMM Q/CHARGER & BLANK
34	FTTAG - STARTER PLATE C/W REWIREABLE SOCKET	41	FTP2UBK - TITAN FB PLATE F/W DUAL USB A CHARGER & BLANK
35	FTTAG2 - DOUBLE STARTER FULL PLATE - REWIREABLE SOCKETS	42	FT2LIDGY-UMB - FLOORBOX LID WITH GALVANISED STEEL LID INSERT AND UMBILICAL GROMMET
36	FTAP2 - POWER PLATE F/W 2 x AUTO SWITCHED GPO WITH BACK BOX	43	FTF2LIDSC-UMB - 2 COMPARTMENT SS SOFT CLOSE FLUSH LID WITH UMBILICAL GROMMET
37	FTAP215A - TITAN PLATE TO SUIT 2 x ROUND 15A GPO WITH BACK BOX	44	FT2LIDSC-UMB - 2 COMPARTMENT SOFT CLOSE RECESSED LID - WITH UMBILICAL GROMMET
38	FTAP2RE - POWER PLATE F/W 2 x AUTO SWITCHED ROUND EARTH GPO WITH BACK BOX	45	FTBP - BLANK PLATE F/W 2 50mm BLANK TILES
39	FTA2UC - FTA2 ACCESS UNDERCARRIAGE	46	FTD2 - ADAPTER PLATE TO SUIT 2 x 50mm SINGLE TILE (PROVISION 2 x DATA)

TITAN FTA2SC

Technical Specification

CMS Titan FTA2SC access floorbox lid and undercarriage. Lid manufactured from stainless steel with 7mm recess provision for carpet tile Insert. Undercarriage manufactured from black powder-coated mild steel. Load capacity: 150kg

ID No.	Part No. & Description
2	FT2LIDSC - STAINLESS SOFT-CLOSE FB2 RECESSED LID
39	FTA2UC - ACCESS UNDERCARRIAGE

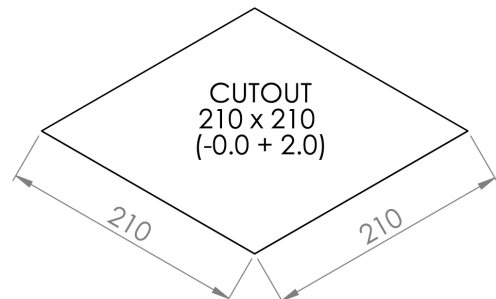
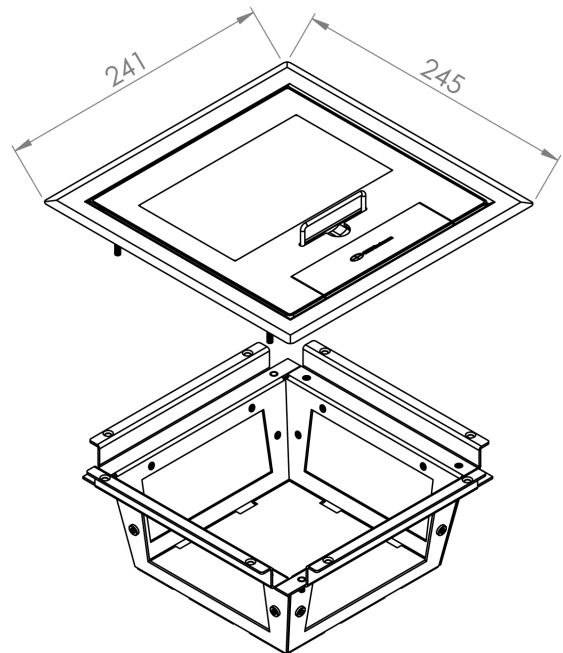
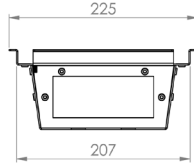
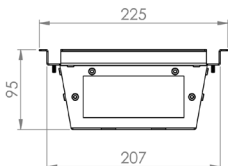
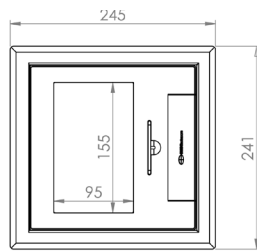
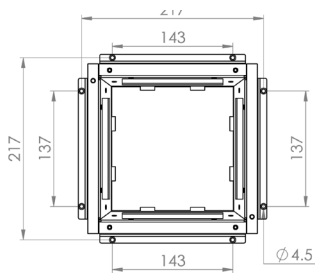

Disclaimer: CMS has made every attempt to ensure the accuracy and reliability of the information provided in this document are correct. All information contained in this document is to be used for general guidance only. CMS reserves the right to change, delete or modify the information without notice.

TITAN FTFA2SC

LID: Stainless steel with flush lid

UNDERCARRIAGE: Access Floor Assembly - 95mm Depth

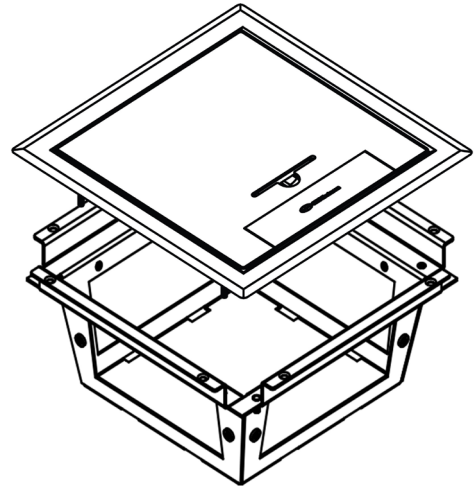

Lid Features

- Soft-closing lid with radius edges minimises risk of accidental impact and potential cable damage.
- Easy-grab handle and functional cable exit when lid closed.
- Lock option available for security applications.

Undercarriage Features

- Designed for AV Integration with Interchangeable mounting plates for Crestron, Extron, Kramer and AMX adapters.
- Wide range of modular soft/hardwired power, data and AV mounting plates.
- CAT6, 6A and 7 Compliant.
- Custom brackets & plates available.
- Designed and manufactured in Australia.

Technical Specification

Floor application	Access raised floor
Cut-out dimension	L210mm x W210mm x D95mm
Lid dimension plus beveled edge	L245mm x W241 mm x D7mm
Lid specification	Stainless steel with flush lid.
Undercarriage and screed box specification	Undercarriage manufactured from black powder-coated mild steel.
Weight rating	150kg

TITAN FTFA2SC

Component List

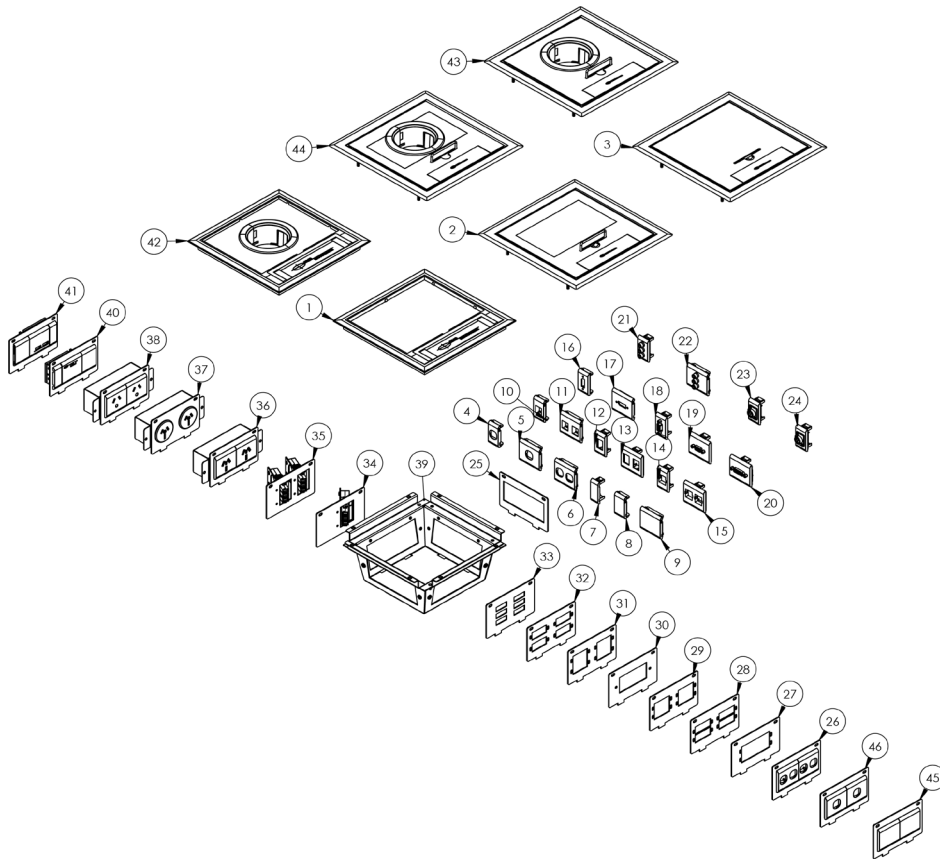

No.	Part No & Description	No.	Part No & Description
1	F2LID - APOLLO FLOORBOX PLASTIC LID	17	SW18CDP1 - 50mm TILE WITH PROVISION FOR DISPLAY PORT
2	FT2LIDSC - STAINLESS SOFT-CLOSE FB2 RECESSED LID	18	SW18BVV - 25mm TILE F/W VGA MINI GENDER BENDER
3	FTF2LIDSC - STAINLESS SOFT-CLOSE FB2 FLUSH LID	19	SW18CVV - 50mm TILE F/W VGA MINI GENDER BENDER
4	SW18B1 - 25mm SINGLE DATA TILE	20	SW18CDVI - 50mm DATA TILE - F/W DVI FEMALE CONNECTOR
5	SW18C1 - 50mm SINGLE DATA TILE	21	
6	SW18C2 - 50mm DUAL DATA TILE	22	
7	SW18A - 18mm blank tile	23	SW18BX3 - 25mm TILE F/W MINI XLR 3 PIN PLUG WITH SOLDER CUPS
8	SW18B - 25mm blank tile	24	SW18BX4 - 25mm TILE F/W MINI XLR 4 PIN PLUG WITH SOLDER CUPS
9	SW18C - 50mm BLANK TILE	25	FTBPP - TITAN 100mm BLANK PLATE
10	SW18B1K - 25mm SINGLE TILE TO SUIT KEYSTONE DATA	26	FTD4 - ADAPTER PLATE TO SUIT 2 x 50mm DUAL TILE (PROVISION 4 x DATA)
11	SW18C2K - 50mm DUAL DATA TILE TO SUIT KEYSTONE JACKS	27	FTEXAAP - AAP EXTRON ADAPTER PLATE TO SUIT 1 x DOUBLE OR 2 x SINGLE MODULES
12	SW18B1SE - 25mm SINGLE TILE TO SUIT SIEMON DATA	28	FTEXMAAP4 - TITAN FLOOR BOX MAAP EXTRON ADAPTER PLATE QUAD
13	SW18C2SE - 50mm DUAL DATA TILE TO SUIT SIEMON JACKS	29	FTKRWD2 - TITAN FLOOR BOX KRAMER ADAPTER TO SUIT "W" xx DOUBLE MODULES
14	SW18B1SM - 25mm SINGLE TILE TO SUIT SYSTIMAX DATA	30	FTKRVS - KRAMER ADAPTER PLATE TO SUIT "SV" xx MODULES
15	SW18C2SM - 50mm DUAL DATA TILE TO SUIT SYSTIMAX DATA	31	FTEXMAAPD2 - TITAN FLOOR BOX MAAP EXTRON ADAPTER PLATE DOUBLE
16	SW18BDP1 - 25mm TILE WITH PROVISION FOR DISPLAY PORT	32	FTKRW4 - TITAN FLOOR BOX KRAMER ADAPTER PLATE TO SUIT "W" xx QUAD MODULES

TITAN FTFA2SC

Component List

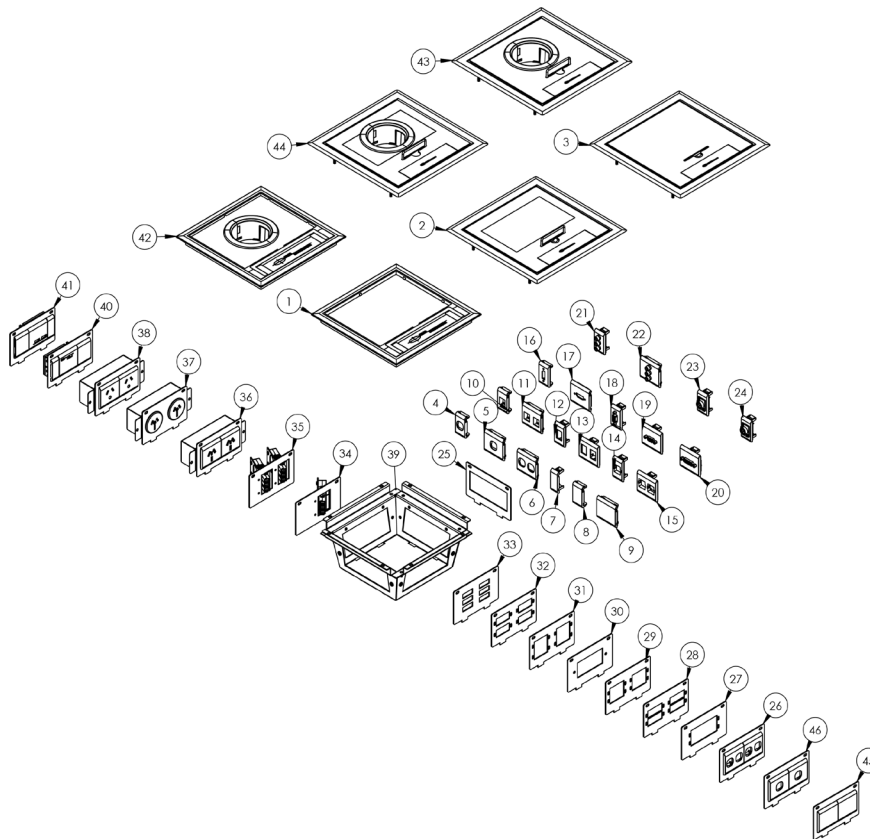

No.	Part No & Description	No.	Part No & Description
33	FTSCD - SC DUPLEX PLATE	40	FTP2UACBK - TITAN FB PLATE F/W DUAL USB TYPE A&C QUALCOMM Q/CHARGER & BLANK
34	FTTAG - STARTER PLATE C/W REWIREABLE SOCKET	41	FTP2UBK - TITAN FB PLATE F/W DUAL USB A CHARGER & BLANK
35	FTTAG2 - DOUBLE STARTER FULL PLATE - REWIREABLE SOCKETS	42	FT2LIDGY-UMB - FLOORBOX LID WITH GALVANISED STEEL LID INSERT AND UMBILICAL GROMMET
36	FTAP2 - POWER PLATE F/W 2 x AUTO SWITCHED GPO WITH BACK BOX	43	FTF2LIDSC-UMB - 2 COMPARTMENT SS SOFT CLOSE FLUSH LID WITH UMBILICAL GROMMET
37	FTAP215A - TITAN PLATE TO SUIT 2 x ROUND 15A GPO WITH BACK BOX	44	FT2LIDSC-UMB - 2 COMPARTMENT SOFT CLOSE RECESSED LID - WITH UMBILICAL GROMMET
38	FTAP2RE - POWER PLATE F/W 2 x AUTO SWITCHED ROUND EARTH GPO WITH BACK BOX	45	FTBP - BLANK PLATE F/W 2 50mm BLANK TILES
39	FTA2UC - FTA2 ACCESS UNDERCARRIAGE	46	FTD2 - ADAPTER PLATE TO SUIT 2 x 50mm SINGLE TILE (PROVISION 2 x DATA)

TITAN FTFA2SC

Technical Specification

CMS Titan FTFA2SC access floorbox lid and undercarriage assembly. Lid manufactured with soft-closing lid with radius edges minimises risk of accidental impact and potential cable damage. Undercarriage manufactured from black powder-coated mild steel. Load capacity: 150kg

ID No.	Part No. & Description
3	FTF2UDSC- STAINLESS SOFT-CLOSE FB2 FLUSH LID
39	FTA2UC - FTA2 ACCESS UNDERCARRIAGE

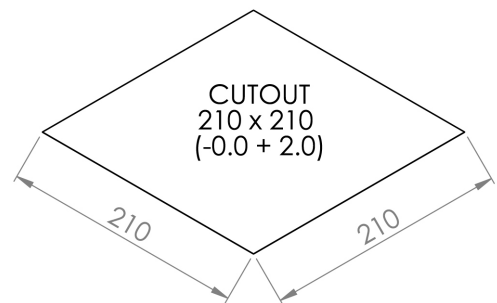
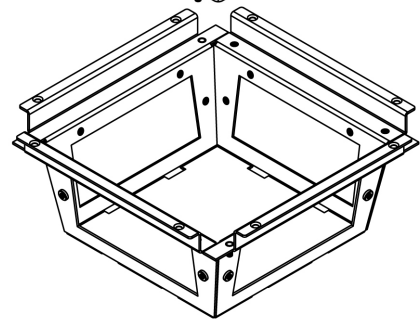
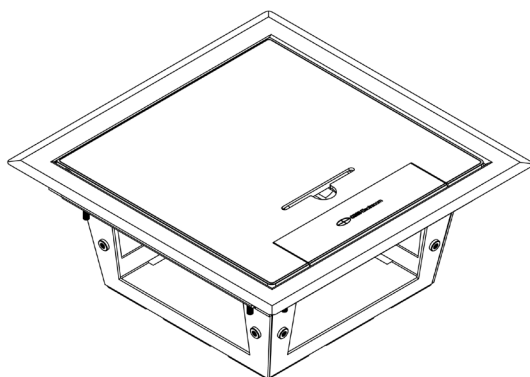
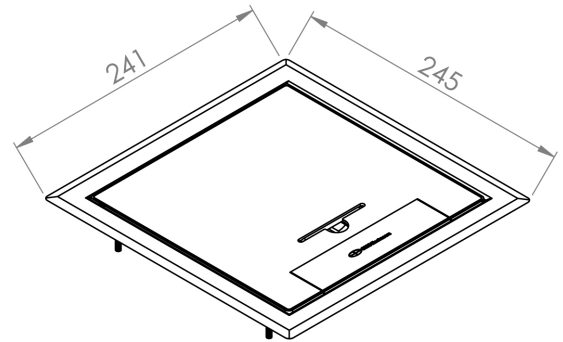
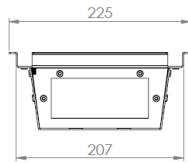
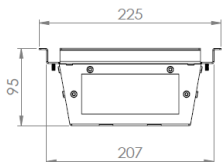
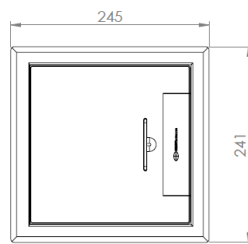
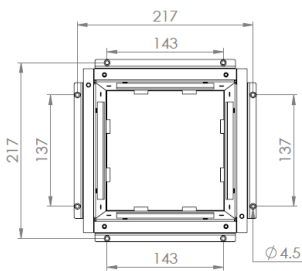

Disclaimer: CMS has made every attempt to ensure the accuracy and reliability of the information provided in this document are correct. All information contained in this document is to be used for general guidance only. CMS reserves the right to change, delete or modify the information without notice.