

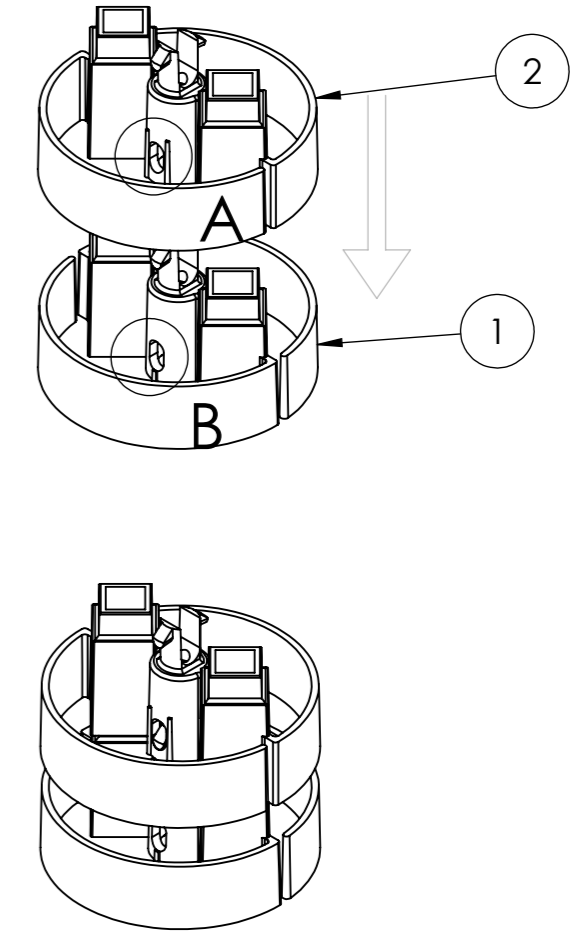

Clip parts together
Alternating between
the two different parts



ITEM NO.	PART NUMBER	QTY.
1	LU21788	45
2	LU21942	46
3	LSG	1
4	LU24166 Circulon top cap	1
5	AXCD	1
6	LU22157_SQUARE BAR EXTRUSIÓN 2996mm LONG	2
7	LU23852	1
8	CQA	1

CUSTOMER SIGNATURE:	TOLERANCES UNLESS OTHERWISE STATED: X ±0.5 X.X ±0.2 X.XX ±0.1 X.XXX ±0.05 ANG ±0.5°	
MATERIAL:		PC
FINISH:		
COLOUR:		
<small>THIS DRAWING & ASSOCIATED CAD FILES ARE ISSUED IN THE STRICTEST CONFIDENCE AND ARE ONLY TO BE USED IN THE COMMERCIAL INTERESTS OF CMS ELECTRACOM PTY LTD</small>		<small>DRAWN IN mm TO AS1100 DO NOT SCALE</small>

 **CMS Electracom** COPYRIGHT © 2015

TITLE: CIRCULON UMBILICAL 3000mm LONG

DRAWING: LU24402 **REV:** 1 **A3**

SCALE 1:2 SHEET 1 OF 1

1	RELEASED FOR PRODUCTION	02/03/2018	KV	AP
REV	DESCRIPTION	DATE	DRWN	APPV
REVISIONS				