

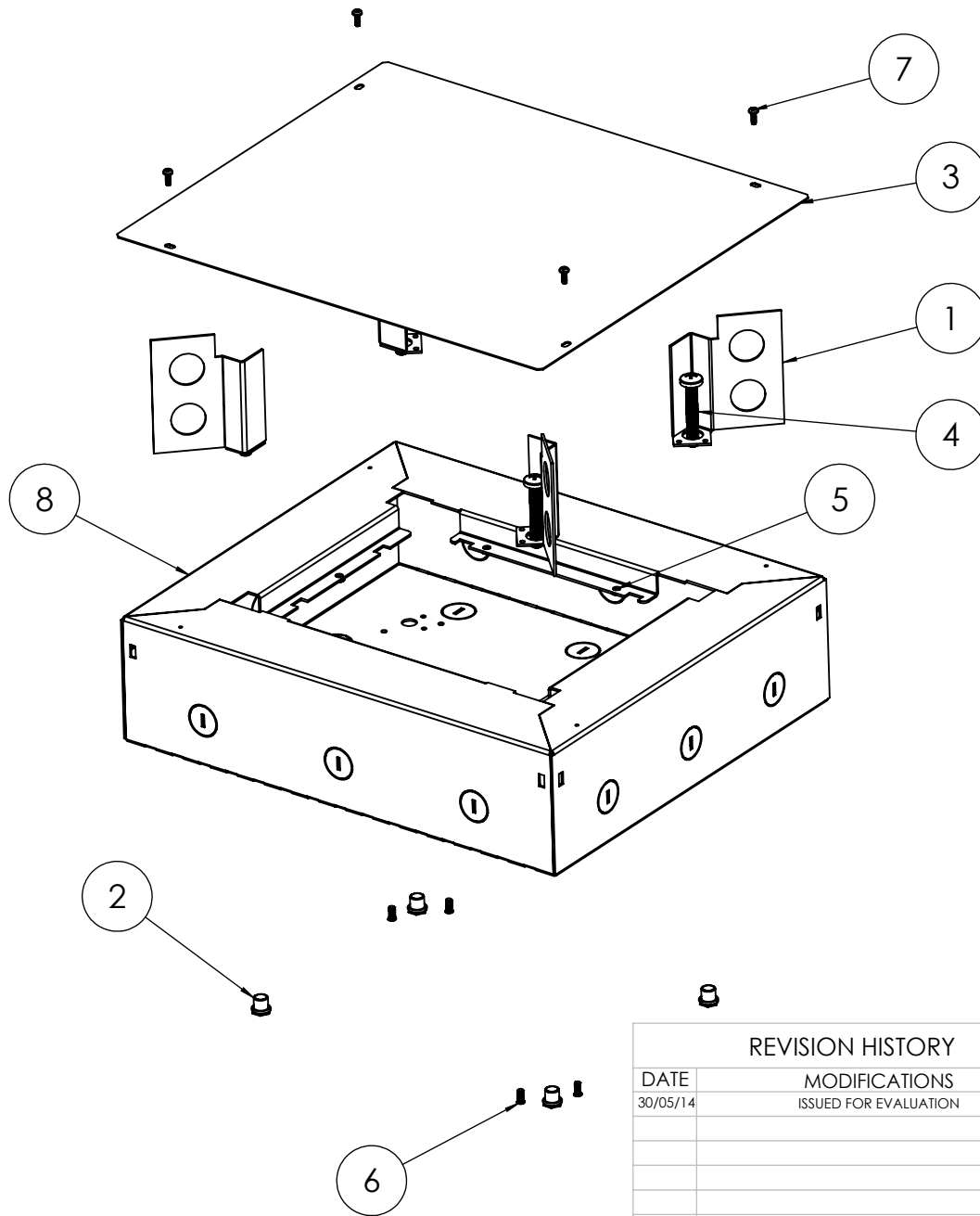

REVISION HISTORY		UNLESS OTHERWISE SPECIFIED: DIMENSIONS ARE IN MILLIMETERS		DO NOT SCALE DRAWING	REVISION 1
DATE	MODIFICATIONS	TOLERANCES			
30/05/14	ISSUED FOR EVALUATION	0.00 ± 0.02 ANGULAR ± 0.5° 0.0 ± 0.1 0 ± 0.5			
		DEBUR AND BREAK SHARP EDGES		TITLE: FT3CH	
		THE MATERIAL CONTAINED HEREIN IS THE SOLE PROPERTY OF CMS ELECTRACOM. ANY UNAUTHORIZED REPRODUCTIONS, MODIFICATIONS AND / OR DISTRIBUTION IS STRICTLY PROHIBITED.			
		NAME	DATE	DWG NO. LU6601	
		LUCKY	30/05/14		
		MATERIAL: 1.6mm Steel		PART NO. TBC	
		FINISH: Galvanized			
		FILE ON SHARED\CAD:		SCALE NTS SHEET 1 OF 2	
		H:\Melbourne\CAD\Current Production Drawings			
		FILE ON NAS:		A4	
		Z:\Work files\Floor boxes\CMS floor box\Production\Titan\FB3\100mm			



ITEM NO.	PART NUMBER	QTY.
1	LU3094_V2_FB4 SP segregation plate	4
2	M8 nut-sert	4
3	LU3793_V1_Titan F3 screed cover plate	1
4	M8 x 50 pan head machine screw	4
5	PEM M4 clinch nut	6
6	M4 x 10 flush head threaded stud	4
7	6G x 3/8" pan head screw	4
8	LU3525_V4_Titan FT3 screed	1

REVISION HISTORY	
DATE	MODIFICATIONS
30/05/14	ISSUED FOR EVALUATION

UNLESS OTHERWISE SPECIFIED: DIMENSIONS ARE IN MILLIMETERS	
TOLERANCES	
0.00 ± 0.02	ANGULAR ± 0.5°
0.0 ± 0.1	
0 ± 0.5	
DEBUR AND BREAK SHARP EDGES	
THE MATERIAL CONTAINED HEREIN IS THE SOLE PROPERTY OF CMS ELECTRACOM. ANY UNAUTHORIZED REPRODUCTIONS, MODIFICATIONS AND / OR DISTRIBUTION IS STRICTLY PROHIBITED.	
NAME	DATE
LUCKY	30/05/14
MATERIAL:	1.6mm Steel
FINISH:	Galvanized
FILE ON SHARED\CAD:	
H:\Melbourne\CAD\Current Production Drawings	
FILE ON NAS:	
Z:\Work files\Floor boxes\CMS floor box\Production\Titan\FB3\100mm	

DO NOT SCALE DRAWING		REVISION	1
			
FT3CH			
DWG. NO.		LU6601	
PART NO.		TBC	
SCALE		NTS	SHEET 2 OF 2
			A4