

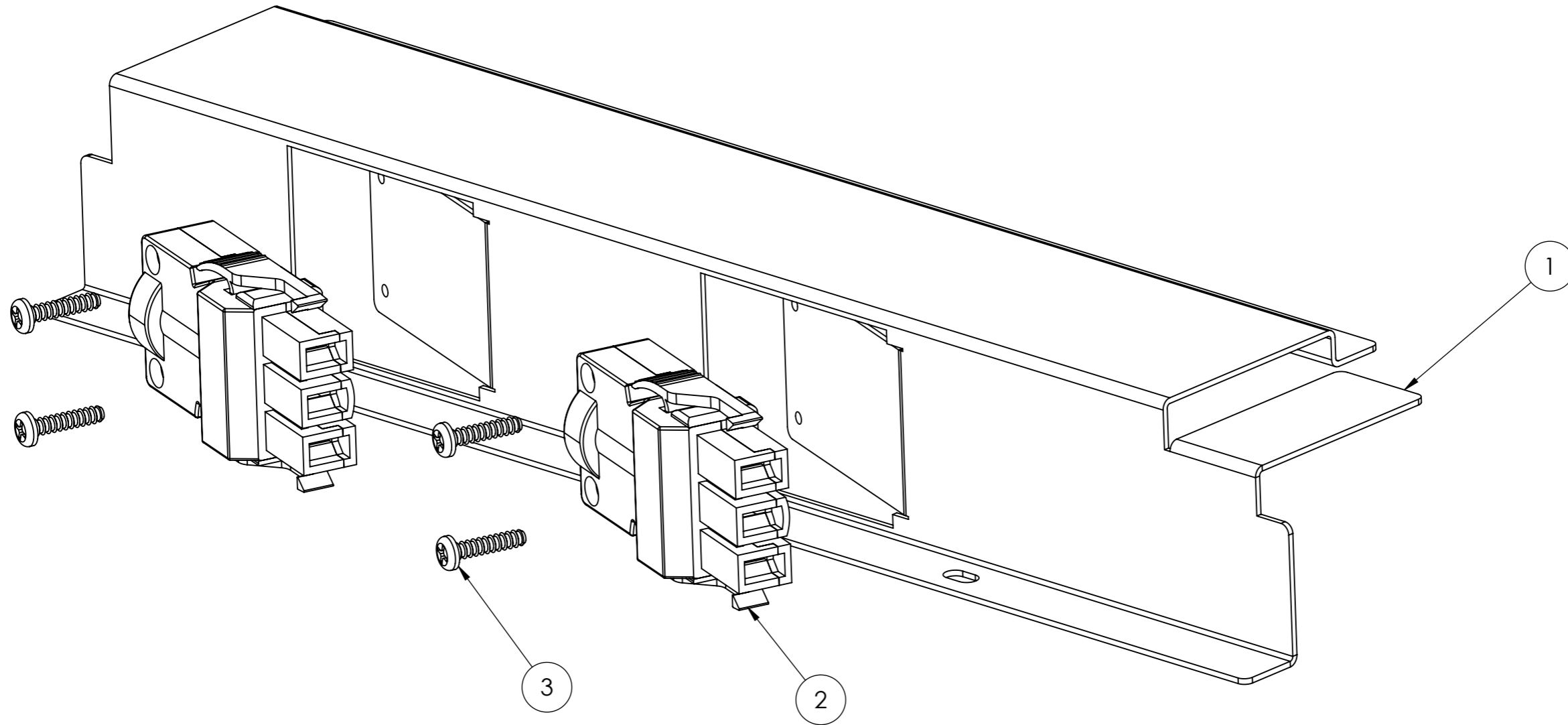

REVISION HISTORY		UNLESS OTHERWISE SPECIFIED: DIMENSIONS ARE IN MILLIMETERS		DO NOT SCALE DRAWING		REVISION 1	
N.	DATE	MODIFICATIONS		TOLERANCES			
1	26/08/11	ISSUED FOR MANUFACTURING		0.00 ± 0.02 ANGULAR ± 0.5° 0.0 ± 0.1 0 ± 0.5			
2				DEBUR AND BREAK SHARP EDGES		TITLE: CMS floor box 60mm large 2 x starter plate	
3				THE MATERIAL CONTAINED HEREIN IS THE SOLE PROPERTY OF CMS ELECTRACOM. ANY UNAUTHORIZED REPRODUCTIONS, MODIFICATIONS AND / OR DISTRIBUTION IS STRICTLY PROHIBITED.			
4				NAME		DWG NO. LU-2500	
5				DATE		PART NO. FBP460ST2	
6				LUCKY		26/08/11	
7				MATERIAL: 1.2mm Steel		SCALE 1:1	
8				FINISH: Powder coat black satin		SHEET 1 OF 2	
9				FILE ON SHARED\CAD:		A3	
10				H:\Melbourne\CAD\Other drawings\Production\Floor box			
11				FILE ON NAS:			
12				Z:\Work files\Floor boxes\CMS floor box\Production\60mm\Large\Plates			
13							



ITEM NO.	PART NUMBER	QTY.
1	LU2500_V1_CMS floor box 60mm large 2 x starter plate	1
2	L3.20BK	2
3	6G x 5/8" pan head screw	4

REVISION HISTORY		UNLESS OTHERWISE SPECIFIED: DIMENSIONS ARE IN MILLIMETERS		DO NOT SCALE DRAWING		REVISION 1	
N.	DATE	MODIFICATIONS		TOLERANCES		TITLE:	
1	26/08/11	ISSUED FOR MANUFACTURING		0.00 ± 0.02	ANGULAR ± 0.5°	 CMS Electracom CMS floor box 60mm large 2 x starter plate	
2				0.0 ± 0.1			
3				0 ± 0.5			
4				DEBUR AND BREAK SHARP EDGES		DWG NO. LU-2500	
5				THE MATERIAL CONTAINED HEREIN IS THE SOLE PROPERTY OF CMS ELECTRACOM. ANY UNAUTHORIZED REPRODUCTIONS, MODIFICATIONS AND / OR DISTRIBUTION IS STRICTLY PROHIBITED.		PART NO. FBP460ST2	
6				NAME DATE		SCALE N/A SHEET 2 OF 2	
7				LUCKY 26/08/11		A3	
8				MATERIAL: 1.2mm Steel			
9				FINISH: Powder coat black satin			
10				FILE ON SHARED\CAD:			
11				H:\Melbourne\CAD\Other drawings\Production\Floor box			
12				FILE ON NAS:			
13				Z:\Work files\Floor boxes\CMS floor box\Production\60mm\Large\Plates			