

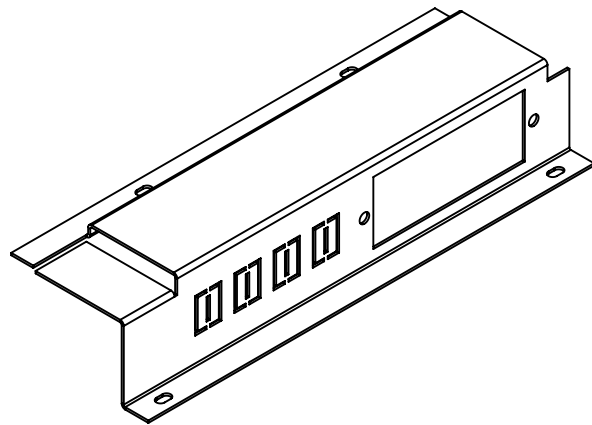

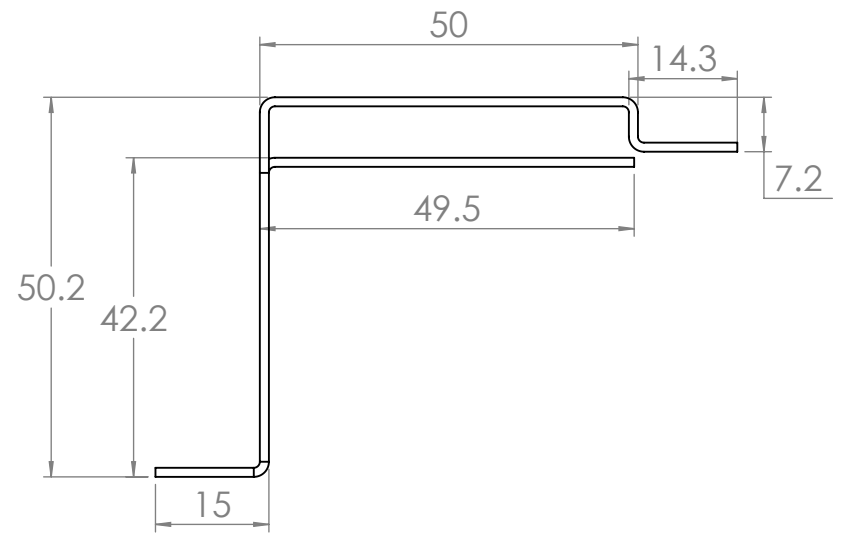

CUSTOMER APPROVAL		REVISION HISTORY		UNLESS OTHERWISE SPECIFIED: DIMENSIONS ARE IN MILLIMETERS TOLERANCES 0.00 ± 0.02 ANGULAR ± 0.5° 0.0 ± 0.1 0 ± 0.5 DIMENSIONS IN AN OBROUND ARE CRITICAL & MUST BE CHECKED	DO NOT SCALE DRAWING		REVISION	1
		DATE	MODIFICATIONS					
		23/10/13	ISSUED FOR MANUFACTURING	TITLE: FB3060 plate with provision for 4 Keystone jacks and AV module				
JG APPROVAL				NAME		DATE		
				LUCKY		23/10/13		
				MATERIAL:		1.2mm Steel		DWG NO.
				FINISH:		Powder coat black satin		
				FILE ON SHARED\CAD:		H:\Melbourne\CAD\Current Production Drawings		PART NO.
				FILE ON NAS:		Z:\Work files\Floor boxes\FB\FB 60mm\Small\FB3060		
				DWG NO.		LU-5808		DRAWN BY
						X		
				PART NO.		X		CHECKED BY
						X		
				SCALE		NTS		SHEET
						1 OF 4		A4

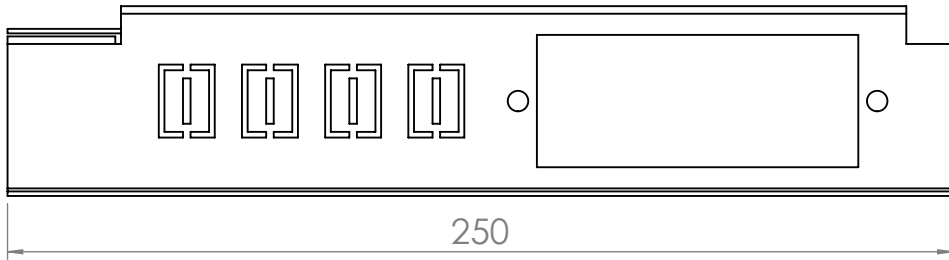

CUSTOMER APPROVAL		REVISION HISTORY		UNLESS OTHERWISE SPECIFIED: DIMENSIONS ARE IN MILLIMETERS TOLERANCES 0.00 ± 0.02 ANGULAR ± 0.5° 0.0 ± 0.1 0 ± 0.5 DIMENSIONS IN AN OBOUND ARE CRITICAL & MUST BE CHECKED	DO NOT SCALE DRAWING	REVISION	1			
JG APPROVAL		DATE	MODIFICATIONS		THE MATERIAL CONTAINED HEREIN IS THE SOLE PROPERTY OF CMS ELECTRACOM. ANY UNAUTHORIZED REPRODUCTIONS, MODIFICATIONS AND / OR DISTRIBUTION IS STRICTLY PROHIBITED.	 TITLE: FB3060 plate with provision for 4 Keystone jacks and AV module				
		23/10/13	ISSUED FOR MANUFACTURING	NAME					DATE	
				LUCKY	23/10/13					
				MATERIAL:	1.2mm Steel	DWG NO.	LU-5808	DRAWN BY	X	A4
				FINISH:	Powder coat black satin	PART NO.	X	CHECKED BY	X	
				FILE ON SHARED\CAD:	H:\Melbourne\CAD\Current Production Drawings	SCALE	NTS	SHEET	2 OF 4	
				FILE ON NAS:	Z:\Work files\Floor boxes\FB\FB 60mm\Small\FB3060					

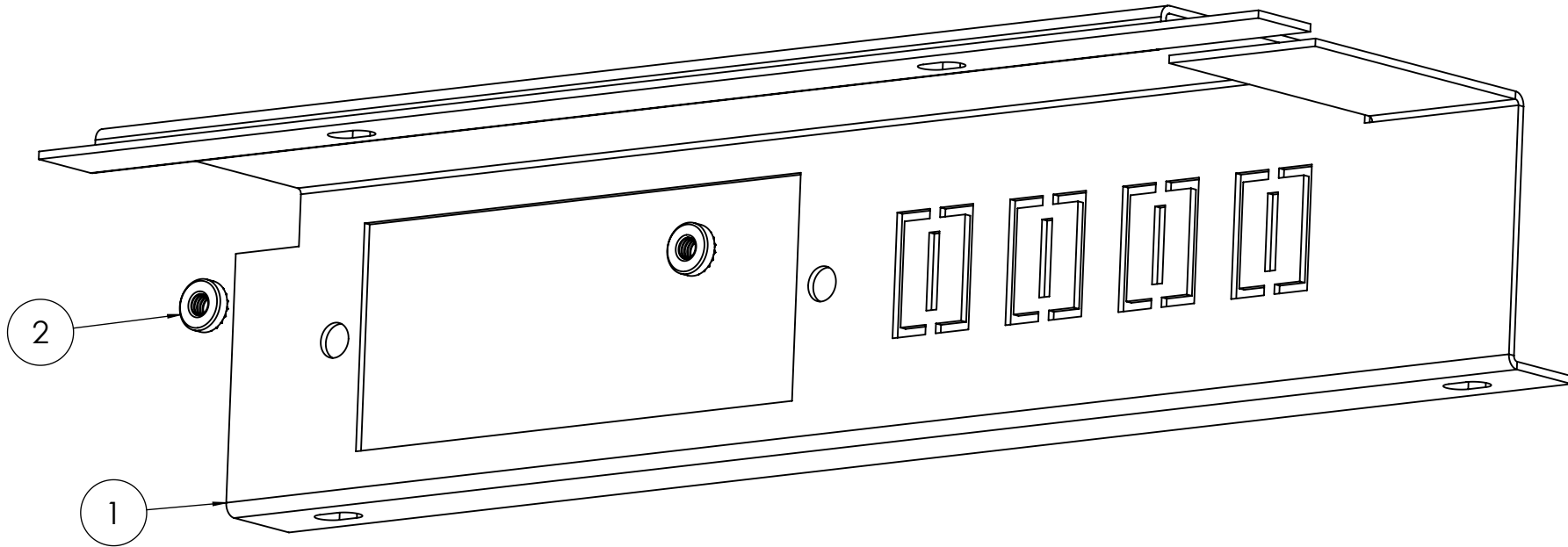

ITEM NO.	PART NUMBER	QTY.
1	LU5808_V1_FB3060 plate with provision for 4 Keystone jacks and AV module	1
2	PEM M4 clinch nut	2

CUSTOMER APPROVAL	REVISION HISTORY		UNLESS OTHERWISE SPECIFIED: DIMENSIONS ARE IN MILLIMETERS TOLERANCES		DO NOT SCALE DRAWING	REVISION	1
	DATE	MODIFICATIONS	0.00 ± 0.02	ANGULAR ± 0.5°		TITLE: FB3060 plate with provision for 4 Keystone jacks and AV module	
	23/10/13	ISSUED FOR MANUFACTURING	0.0 ± 0.1				
JG APPROVAL			0 ± 0.5		DWG NO. LU-5808		DRAWN BY X
			<small>DIMENSIONS IN AN OBOUND ARE CRITICAL & MUST BE CHECKED</small>		PART NO. X		CHECKED BY X
			<small>THE MATERIAL CONTAINED HEREIN IS THE SOLE PROPERTY OF CMS ELECTRACOM. ANY UNAUTHORIZED REPRODUCTIONS, MODIFICATIONS AND / OR DISTRIBUTION IS STRICTLY PROHIBITED.</small>		SCALE NTS		SHEET 3 OF 4
			<small>NAME DATE</small> LUCKY 23/10/13		A4		
			<small>MATERIAL: 1.2mm Steel</small>				
			<small>FINISH: Powder coat black satin</small>				
			<small>FILE ON SHARED\CAD: H:\Melbourne\CAD\Current Production Drawings</small>				
			<small>FILE ON NAS: Z:\Work files\Floor boxes\FB\FB 60mm\Small\FB3060</small>				

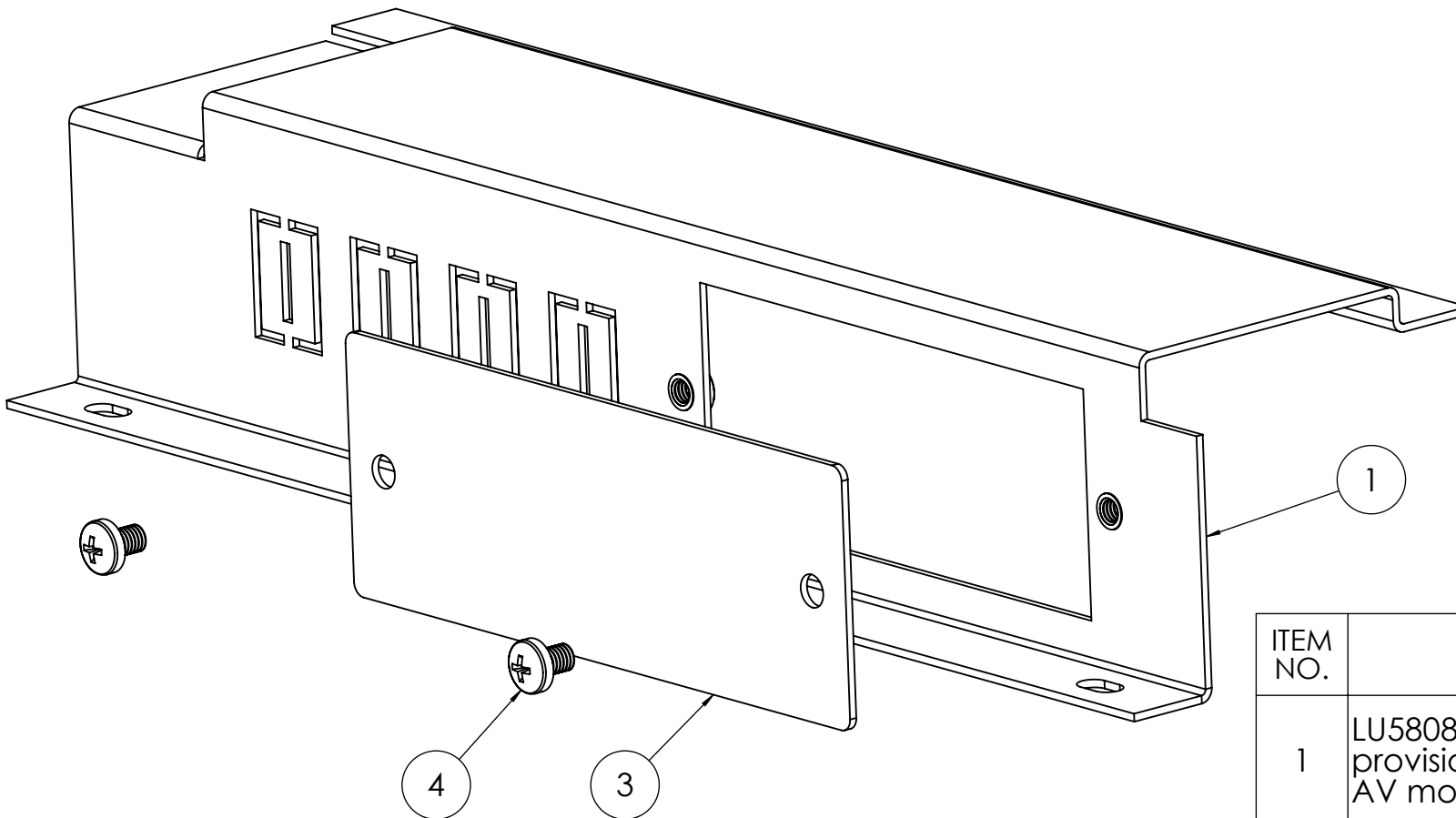

ITEM NO.	PART NUMBER	QTY.
1	LU5808_V1_FB3060 plate with provision for 4 Keystone jacks and AV module	1
2	PEM M4 clinch nut	2
3	LU5809_V1_AV module plate	1
4	M4 x 6 pan head machine screw	2

CUSTOMER APPROVAL	REVISION HISTORY		UNLESS OTHERWISE SPECIFIED: DIMENSIONS ARE IN MILLIMETERS TOLERANCES 0.00 ± 0.02 ANGULAR ± 0.5° 0.0 ± 0.1 0 ± 0.5 DIMENSIONS IN AN OBOUND ARE CRITICAL & MUST BE CHECKED	DO NOT SCALE DRAWING	REVISION	1
	DATE	MODIFICATIONS			TITLE: FB3060 plate with provision for 4 Keystone jacks and AV module	
23/10/13	ISSUED FOR MANUFACTURING	NAME	DATE			
JG APPROVAL		LUCKY	23/10/13	LU-5808	X	
				PART NO.	X	
				SCALE	NTS	SHEET 4 OF 4
				FILE ON SHARED\CAD: H:\Melbourne\CAD\Current Production Drawings		
				FILE ON NAS: Z:\Work_files\Floor boxes\FB\60mm\Small\FB3060		