

COLOUR VARIATIONS		
PART NUMBER	PLASTIC COMPONENTS	EXTRUSION
WT	WHITE	ANODISED SILVER
BK	BLACK	ANODISED SILVER
BK/BK	BLACK	POWDERCOATED BLACK MANNEX
WT/WT	WHITE	POWDERCOATED WHITE SATIN
WT/WM	WHITE	POWDERCOATED WHITE MANNEX

NOTE:

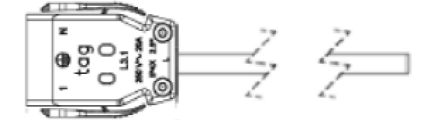

CABLE TYPE: 2.5MM  
 DESCRIPTION: TAG CONNECTOR LEAD  
 COLOUR: WHITE OR BLACK  
 (REFER TO PURCHASE ORDER)  
 LENGTH (mm):

xx	LENGTH (mm)
05	500
10	1000
15	1500
20	2000
25	2500
30	3000
35	3500
40	4000
45	4500
50	5000

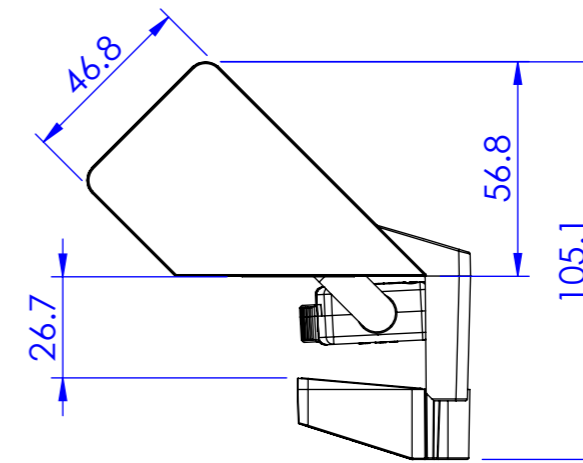
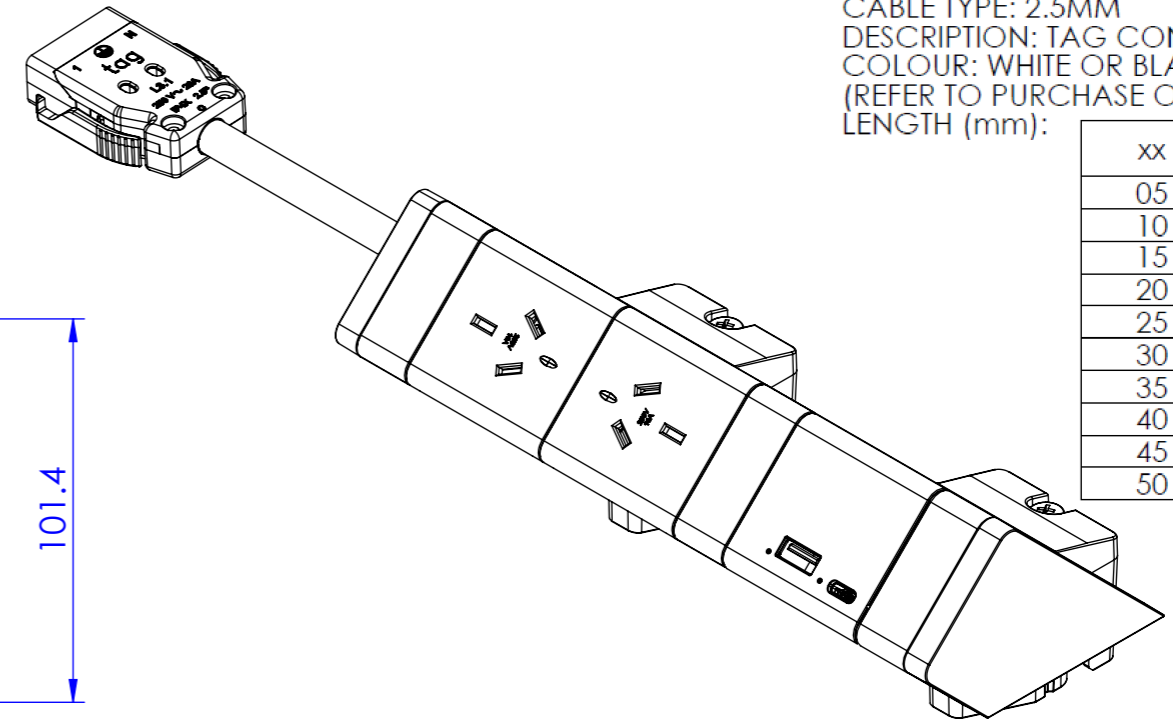
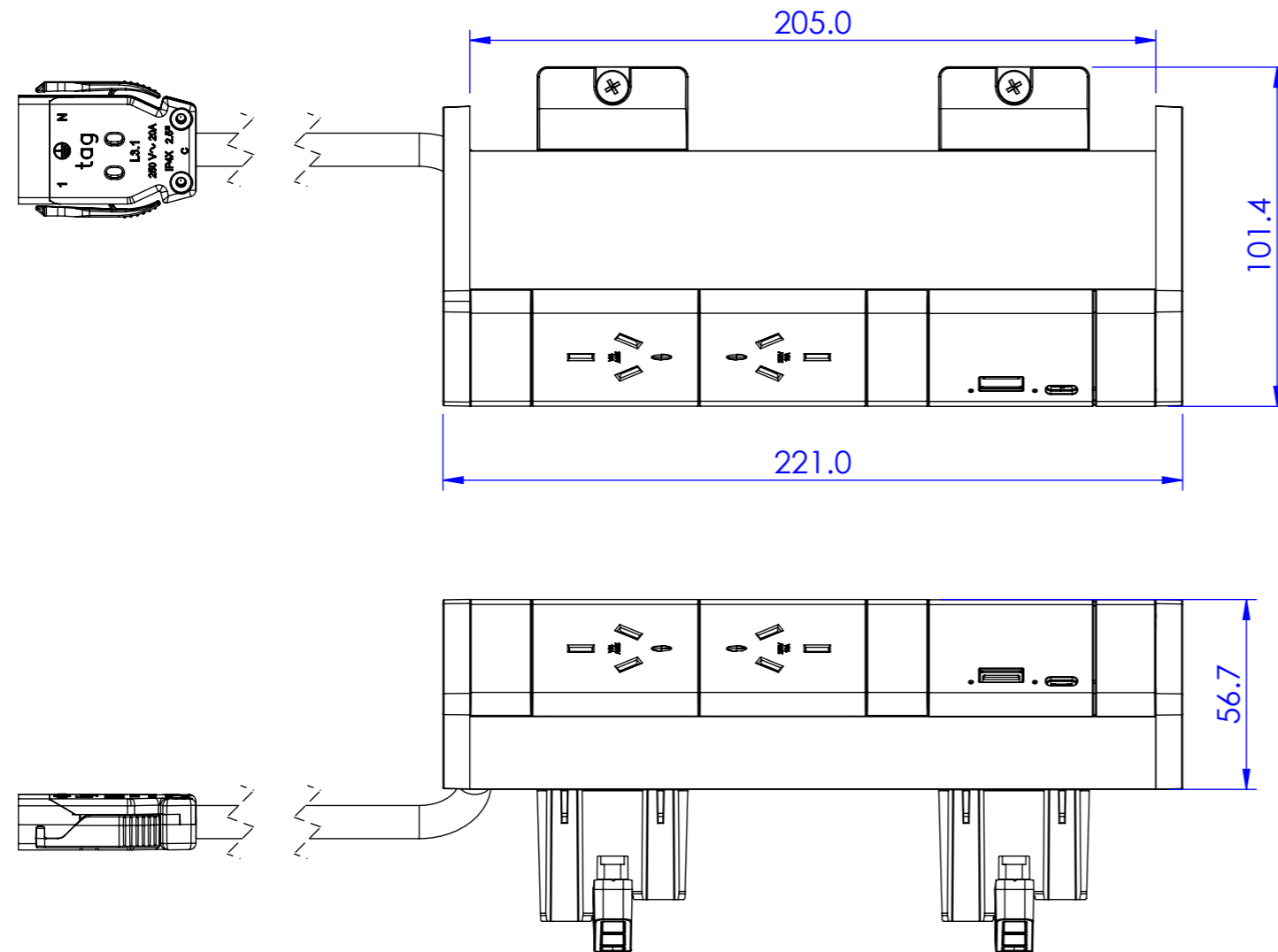

**PART NUMBER: AN02RUAC3xxXX**

NOTE - xx - LENGTH - 05 / 10 / 15 / 20 / 25 / 30 / 35 / 40 / 45 / 50  
 XX - COLOUR - WT / BK / (BK/BK) / (WT/WT) / (WT/WM)

<b>CUSTOMER SIGNATURE:</b>	<b>TOLERANCES UNLESS OTHERWISE STATED:</b>  X ±0.5 X.X ±0.2 X.XX ±0.1 X.XXX ±0.05 ANG ±0.5°	 <b>CMS Electracom</b> COPYRIGHT © 2015
<b>MATERIAL:</b> POLYCARBONATE / ALUMINIUM		
<b>FINISH:</b> FINE EDM / ANODISED (POWDER COAT)		<b>TITLE:</b> <b>ATHENA 2 WITH 2 ROTATED AU GPO + 1 SW18UAC3FL</b>
<b>COLOUR:</b> REFER TABLE	<b>DRAWING:</b> LU33522	<b>REV:</b> 3
THIS DRAWING & ASSOCIATED CAD FILES ARE ISSUED IN THE STRICTEST CONFIDENCE AND ARE ONLY TO BE USED IN THE COMMERCIAL INTERESTS OF CMS ELECTRACOM PTY LTD	<b>SCALE 1:2</b>	<b>A3</b>
	<b>SHEET 1 OF 2</b>	

REV	DESCRIPTION	DATE	DRWN	APPV
3	ROUTING DETAIL UPATED	5/11/2024	JB	RG
2	WIRING DIAGRAM UPDATED	18/8/2020	JB	RG
1	RELEASED FOR PRODUCTION	8/11/2019	JB	AP
REVISIONS				