

FRONT VIEW

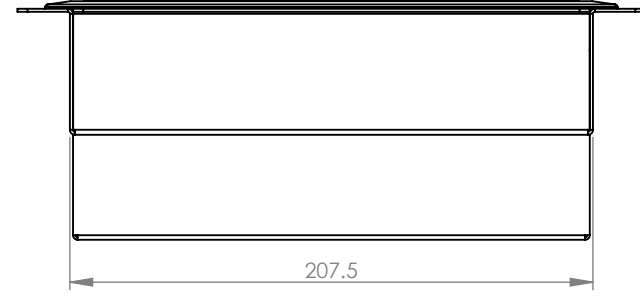

END VIEW

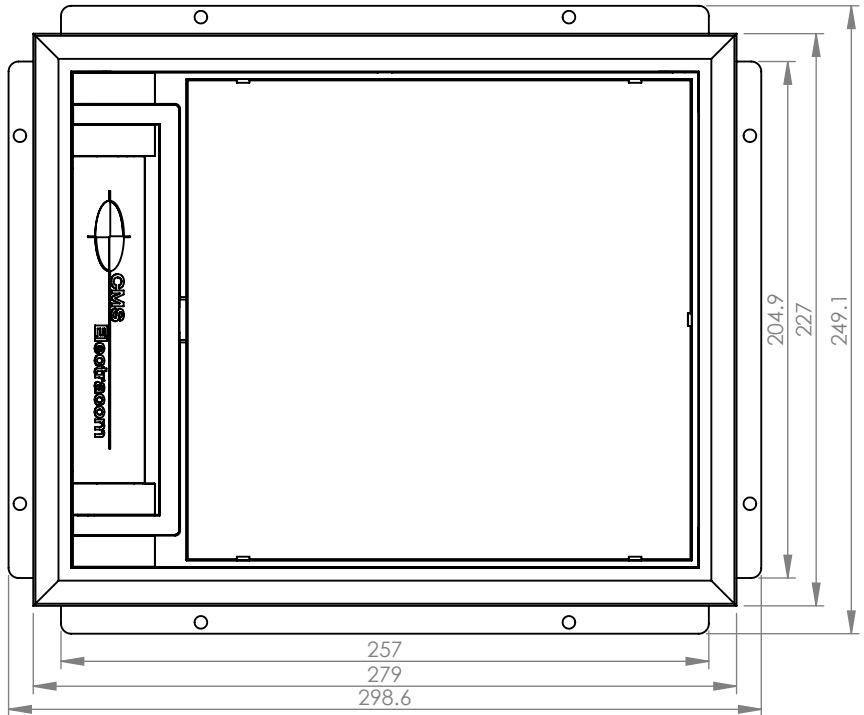

TOP VIEW

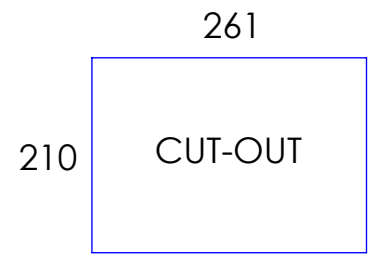
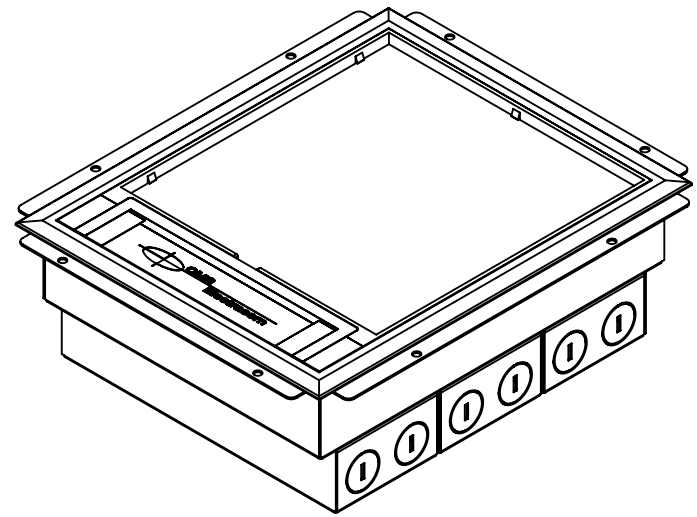

REVISION HISTORY		UNLESS OTHERWISE SPECIFIED: DIMENSIONS ARE IN MILLIMETERS		DO NOT SCALE DRAWING	REVISION	2
DATE	MODIFICATIONS	TOLERANCES				
29/08/12	ISSUED FOR MANUFACTURING	0.00 ± 0.02	ANGULAR ± 0.5*			
07/05/13	MODIFIED CHASSIS	0.0 ± 0.1		TITLE: FL3090		
		0 ± 0.5				
		DEBUR AND BREAK SHARP EDGES		DWG NO. LU-3412		
		THE MATERIAL CONTAINED HEREIN IS THE SOLE PROPERTY OF CMS ELECTRACOM. ANY UNAUTHORIZED REPRODUCTIONS, MODIFICATIONS AND / OR DISTRIBUTION IS STRICTLY PROHIBITED.				
		NAME	DATE	PART NO. TBC		
		LUCKY	07/05/13			
		MATERIAL: X		SCALE NTS SHEET 1 OF 2		
		FINISH: X				
		FILE ON SHARED\CAD: H:\Melbourne\CAD\Current Production Drawings		A4		
		FILE ON NAS: Z:\Work files\Floor boxes\FLV\FL3				

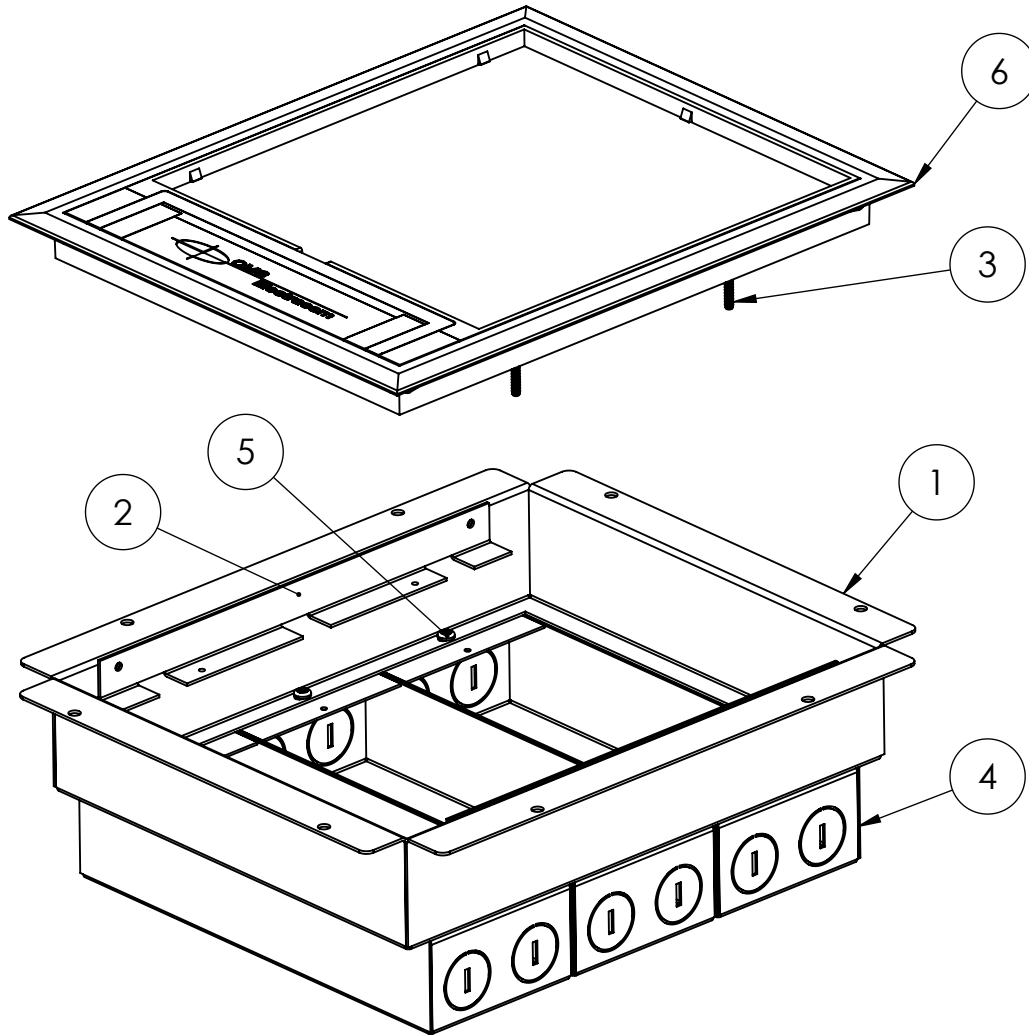

ITEM NO.	PART NUMBER	QTY.
1	LU3405_V2_FL3090 undercarriage	1
2	LU3410_V1_FL3 support plate	2
3	6G x 3/4" blind CSK screw (To fix lid)	4
4	LU1408_V5_Acessories box extended	3
5	6G x 3/8" pan head screw	6
6	F3 lid	1

REVISION HISTORY		UNLESS OTHERWISE SPECIFIED: DIMENSIONS ARE IN MILLIMETERS		DO NOT SCALE DRAWING		REVISION 2			
DATE	MODIFICATIONS	TOLERANCES							
29/08/12	ISSUED FOR MANUFACTURING	0.00 ± 0.02	ANGULAR ± 0.5°						
07/05/13	MODIFIED CHASSIS	0.0 ± 0.1		TITLE: <div style="text-align: center; font-size: 24px;">FL3090</div>					
		0 ± 0.5							
		DEBUR AND BREAK SHARP EDGES		NAME		DATE			
		THE MATERIAL CONTAINED HEREIN IS THE SOLE PROPERTY OF CMS ELECTRACOM. ANY UNAUTHORIZED REPRODUCTIONS, MODIFICATIONS AND / OR DISTRIBUTION IS STRICTLY PROHIBITED.		LUCKY		07/05/13			
				MATERIAL: X		DWG NO.		LU-3412	
				FINISH: X		PART NO.		TBC	
				FILE ON SHARED\CAD:		SCALE		SHEET 2 OF 2	
		H:\Melbourne\CAD\Current Production Drawings		NTS					
		FILE ON NAS:		Z:\Work files\Floor boxes\FL\FL3					
		Z:\Work files\Floor boxes\FL\FL3				A4			