

FRONT VIEW

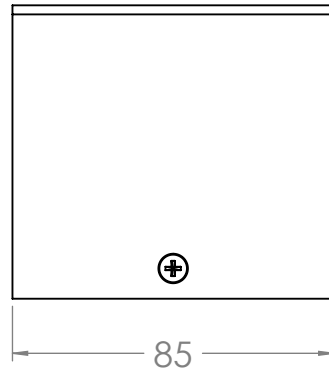

END VIEW

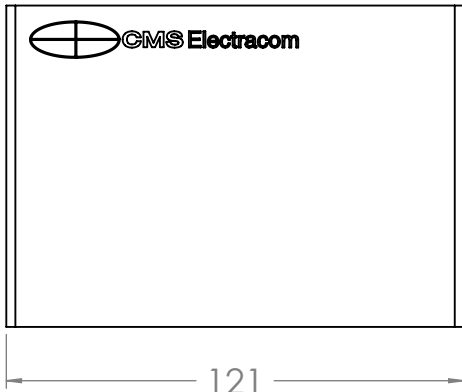

TOP VIEW

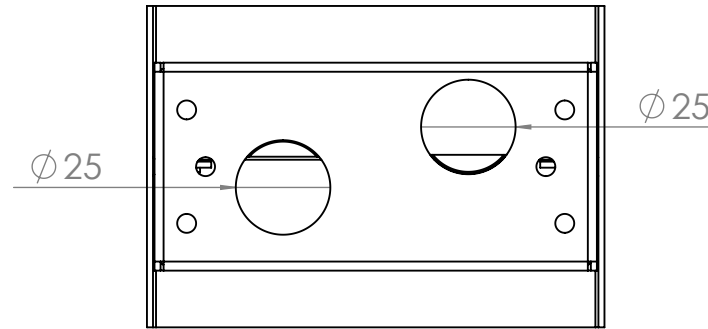

BOTTOM VIEW

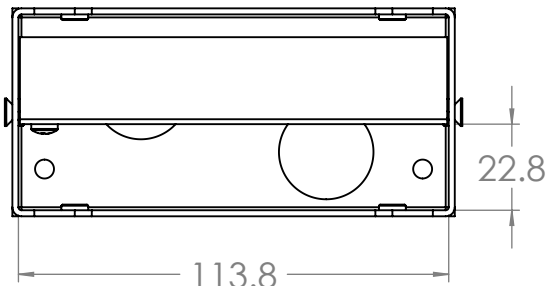
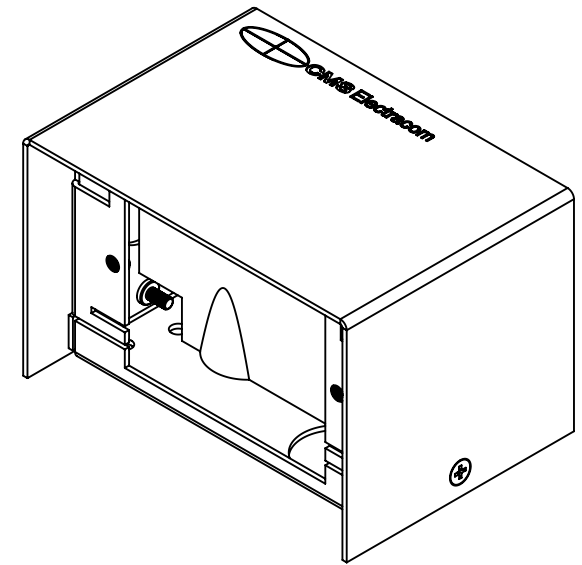

INTERNAL VIEW

REVISION HISTORY		UNLESS OTHERWISE SPECIFIED: DIMENSIONS ARE IN MILLIMETERS		DO NOT SCALE DRAWING	REVISION	3
N.	DATE	MODIFICATIONS	TOLERANCES	 TITLE: G1		
1	15/02/13	ISSUED FOR MANUFACTURING	0.00 ± 0.02 ANGULAR ± 0.5° 0.0 ± 0.1 0 ± 0.5			
2	22/02/13	UPDATED COVER	DIMENSIONS IN AN OBOUND ARE CRITICAL & MUST BE CHECKED			
3	14/03/13	UPDATED FRAME & BARRIER	THE MATERIAL CONTAINED HEREIN IS THE SOLE PROPERTY OF CMS ELECTRACOM. ANY UNAUTHORIZED REPRODUCTIONS, MODIFICATIONS AND / OR DISTRIBUTION IS STRICTLY PROHIBITED.			
4						
5						
6						
7						
8						
9						
10						
11						
12						
13						
			NAME	DATE		
			LUCKY	14/03/13		
			MATERIAL:	X	DWG NO.	LU-4709
			FINISH:	X	DRAWN BY	X
			FILE ON SHARED\CAD:	H:\Melbourne\CAD\Current Production Drawings	PART NO.	X
			FILE ON NAS:	Z:\Work files\Floor boxes\G1	CHECKED BY	X
					SCALE	1:2
					SHEET	1 OF 2
						A4

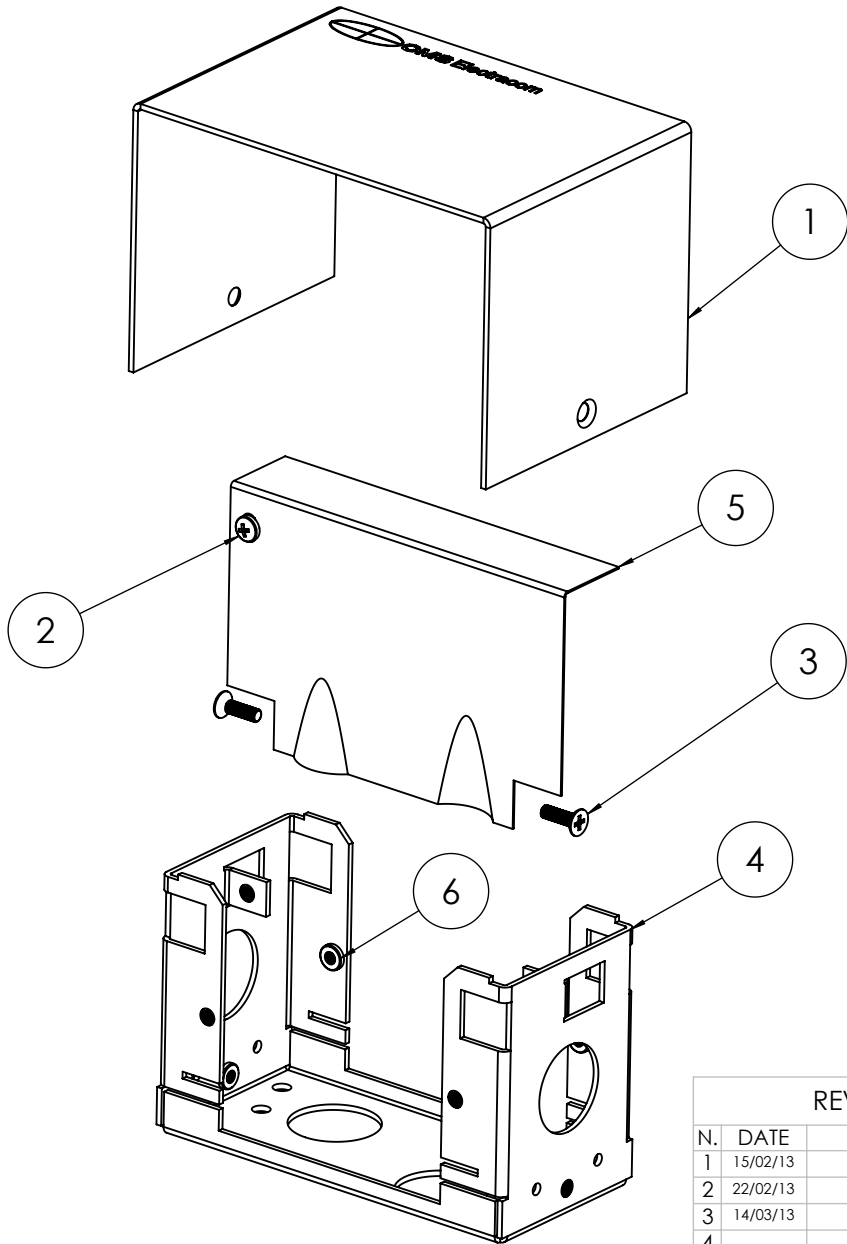

ITEM NO.	PART NUMBER	QTY.
1	LU3257_V2_G1 external housing	1
2	M3.5 x 12 pan head machine screw	1
3	M3.5 x 12 CSK machine screw STAINLESS STEEL	2
4	LU4707_V2_G1 frame MKII	1
5	LU4708_V2_G1 divider MKII	1
6	PEM M3.5 clinch nut	7

REVISION HISTORY		UNLESS OTHERWISE SPECIFIED: DIMENSIONS ARE IN MILLIMETERS		DO NOT SCALE DRAWING		REVISION	
N.	DATE	MODIFICATIONS		TOLERANCES		3	
1	15/02/13	ISSUED FOR MANUFACTURING		0.00 ± 0.02 ANGULAR ± 0.5° 0.0 ± 0.1 0 ± 0.5		 CMS Electracom TITLE: <div style="text-align: center; font-size: 2em;">G1</div>	
2	22/02/13	UPDATED COVER		DIMENSIONS IN AN OBOUND ARE CRITICAL & MUST BE CHECKED			
3	14/03/13	UPDATED FRAME & BARRIER		THE MATERIAL CONTAINED HEREIN IS THE SOLE PROPERTY OF CMS ELECTRACOM. ANY UNAUTHORIZED REPRODUCTIONS, MODIFICATIONS AND / OR DISTRIBUTION IS STRICTLY PROHIBITED.			
4							
5							
6							
7							
8							
9							
10							
11							
12							
13							
		NAME		DATE		DWG NO.	
		LUCKY		14/03/13		LU-4709	
		MATERIAL:		X		DRAWN BY	
		FINISH:		X		X	
		FILE ON SHARED\CAD:		H:\Melbourne\CAD\Current Production Drawings		PART NO.	
		FILE ON NAS:		Z:\Work files\Floor boxes\G1		X	
						CHECKED BY	
						X	
						SCALE	
						NTS	
						SHEET	
						2 OF 2	
						A4	