

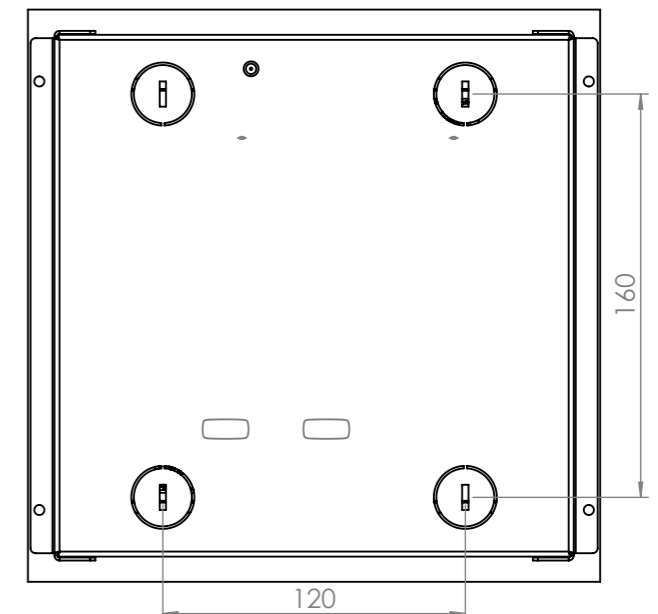

SECTION A-A

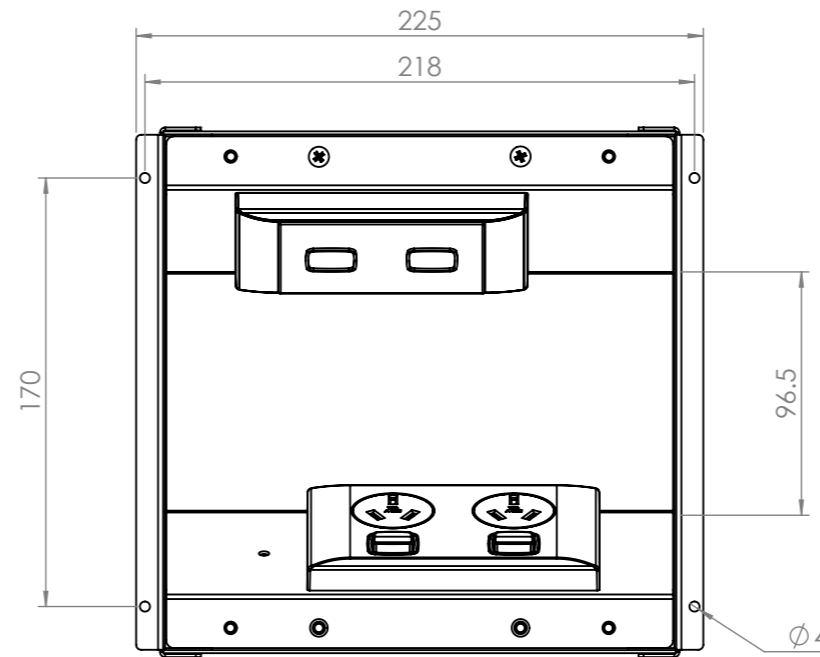
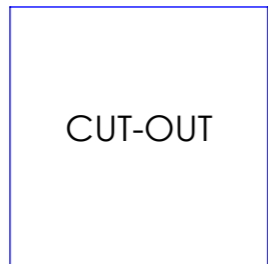
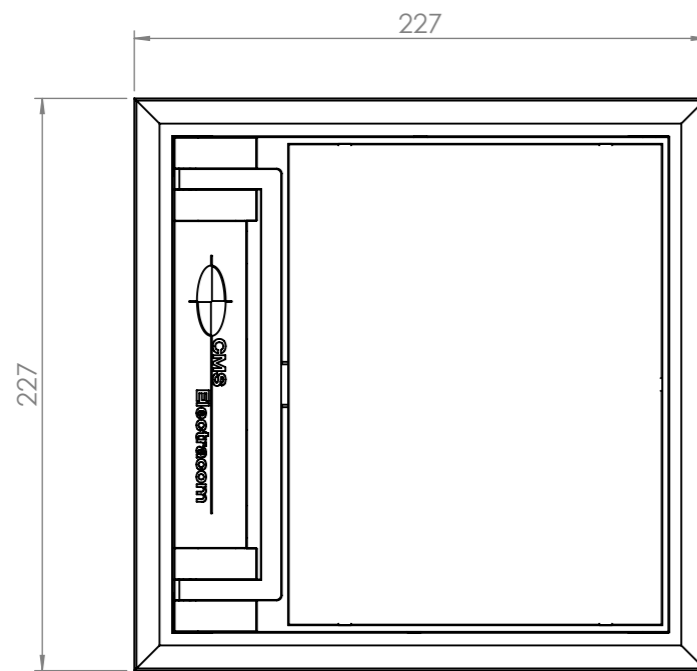
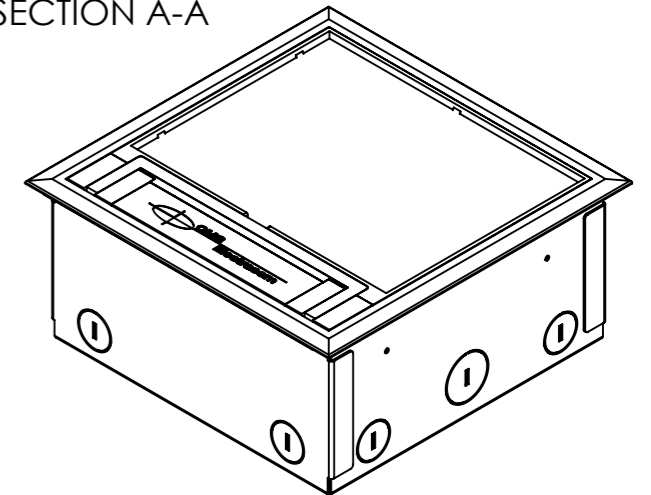

REV	DESCRIPTION	DATE	DRWN	APPV
10	ADDED GAL INSERT PLATE FOR LID	4/02/2019	JC	RG
9	UPDATED SCREWS IN BOM	28/08/2018	JC	AP
8	UPDATED BOM	27/06/2018	JC	AP
7	RELEASED FOR PRODUCTION	23/05/2018	JC	AP
6	RELEASED FOR QUOTATION - NOT FOR PRODUCTION	22/05/2018	JC	AP
REVISIONS				

CUSTOMER SIGNATURE:
MATERIAL: PLASTIC / MS
FINISH: TEXTURED / POWDERCOATED
COLOUR: BLACK SATIN
THIS DRAWING & ASSOCIATED CAD FILES ARE ISSUED IN THE STRICTEST CONFIDENCE AND ARE ONLY TO BE USED IN THE COMMERCIAL INTERESTS OF CMS ELECTRACOM PTY LTD

TOLERANCES UNLESS OTHERWISE STATED: X ±0.5 X.X ±0.2 X.XX ±0.1 X.XXX ±0.05 ANG ±0.5°
DRAWN IN mm TO AS1100 DO NOT SCALE

 **CMS Electracom** COPYRIGHT © 2015

TITLE: CT02GY/BK CENTURY BOX

DRAWING: LU20294 **REV:** 10 **A3**

SCALE 1:3 SHEET 1 OF 2

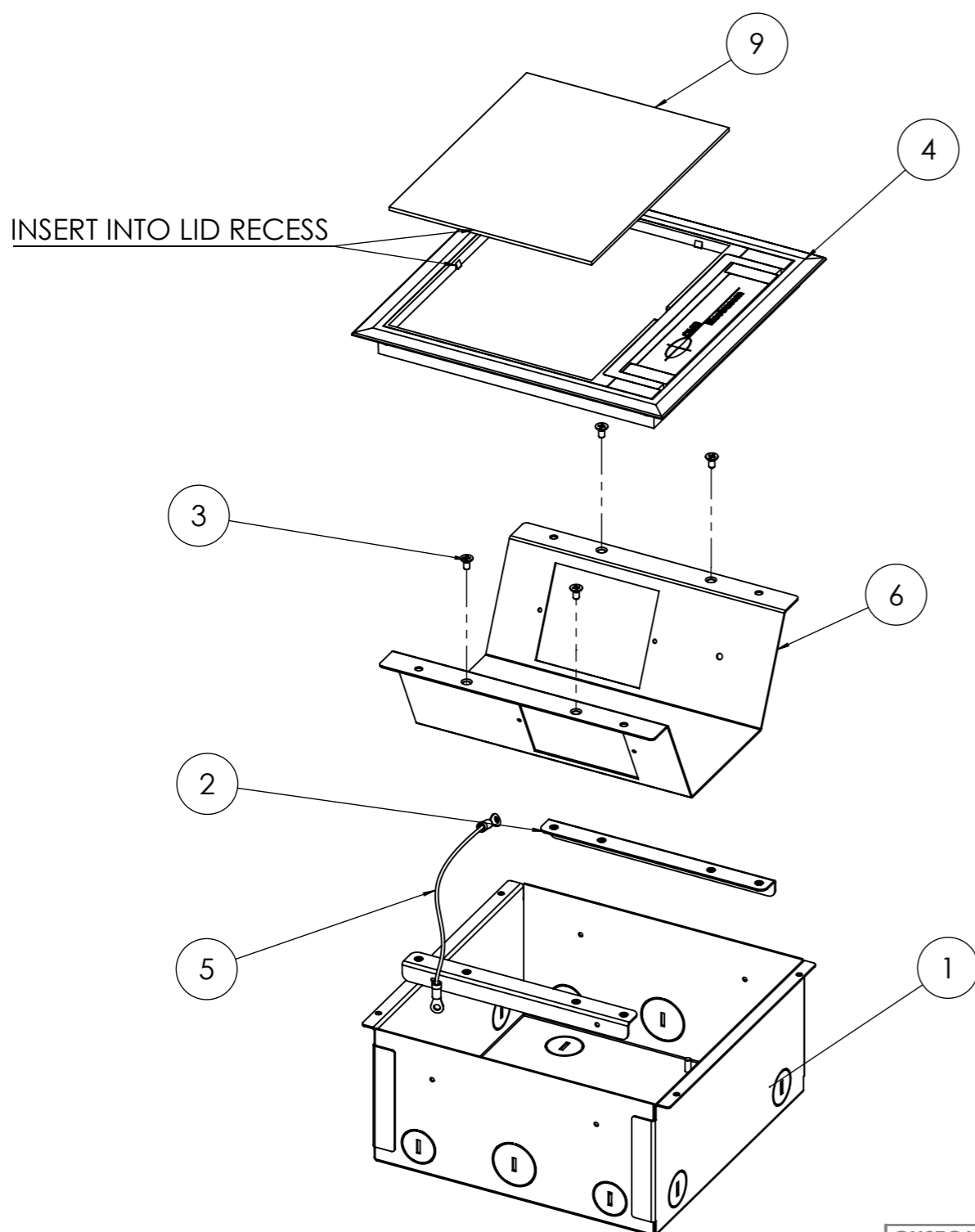

- 7 INCLUDE IN A SACHEL
4x 6G x 1" TYPE B PAN HEAD SELF TAP
- AND
- 8 4x M4 x 20 CSK MACHINE SCREW

ITEM NO.	PART NUMBER	QTY.
1	LU20287_FB UNDERCARRIAGE TO SUIT SMALL CENTURY BOX	1
2	LU20290_FB SMALL SUPPORT PLATE	2
3	M4 X 8 CSK MACHINE SCREWS	4
4	F2 lid	1
5	LU9436_150mm EARTH STRAP FROM GPO PLATE TO UNDERARRIAGE	1
6	LU20288_SMALL SIZE FB plate	1
7	6G x 1" TYPE B PAN HEAD SELF TAP	4
8	M4 x 20 CSK MACHINE SCREW	4
9	LU1344 small gal. insert	1

CUSTOMER SIGNATURE: MATERIAL: PLASTIC / MS FINISH: TEXTURED / POWDERCOATED COLOUR: BLACK SATIN		TOLERANCES UNLESS OTHERWISE STATED: X ±0.5 X.X ±0.2 X.XX ±0.1 X.XXX ±0.05 ANG ±0.5°		 CMS Electracom		COPYRIGHT © 2015	
THIS DRAWING & ASSOCIATED CAD FILES ARE ISSUED IN THE STRICTEST CONFIDENCE AND ARE ONLY TO BE USED IN THE COMMERCIAL INTERESTS OF CMS ELECTRACOM PTY LTD				DRAWN IN mm TO AS1100 DO NOT SCALE		TITLE: CT02GY/BK CENTURY BOX	
DRAWING: LU20294		REV: 10		A3		SCALE 1:4	
				SHEET 2 OF 2			