

SECTION A-A

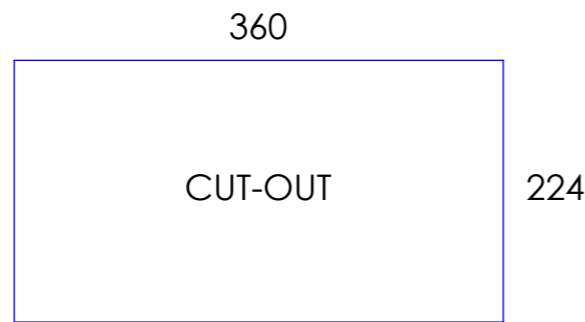
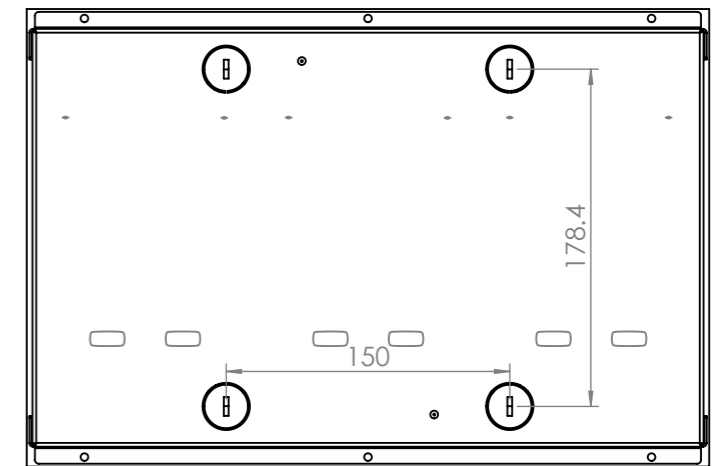
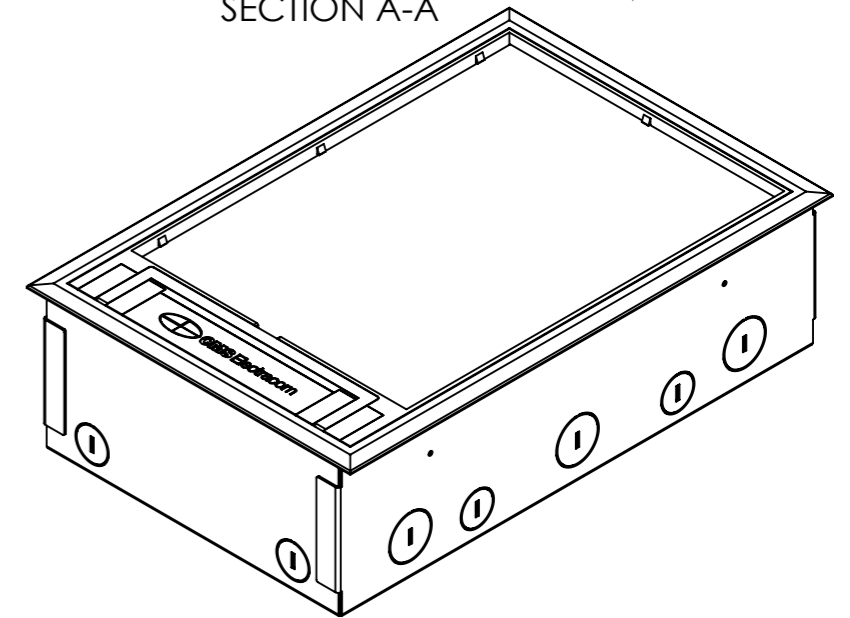
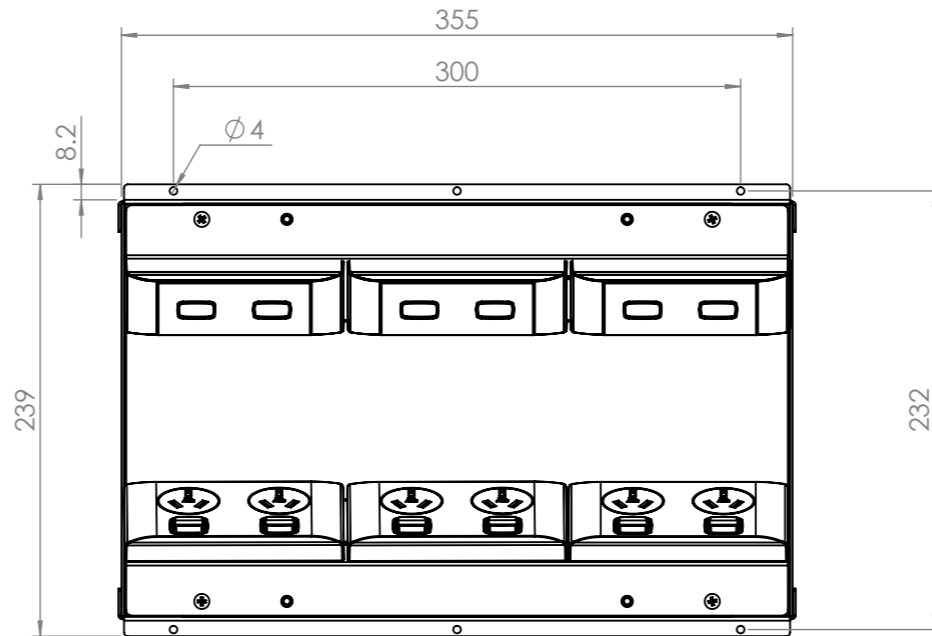
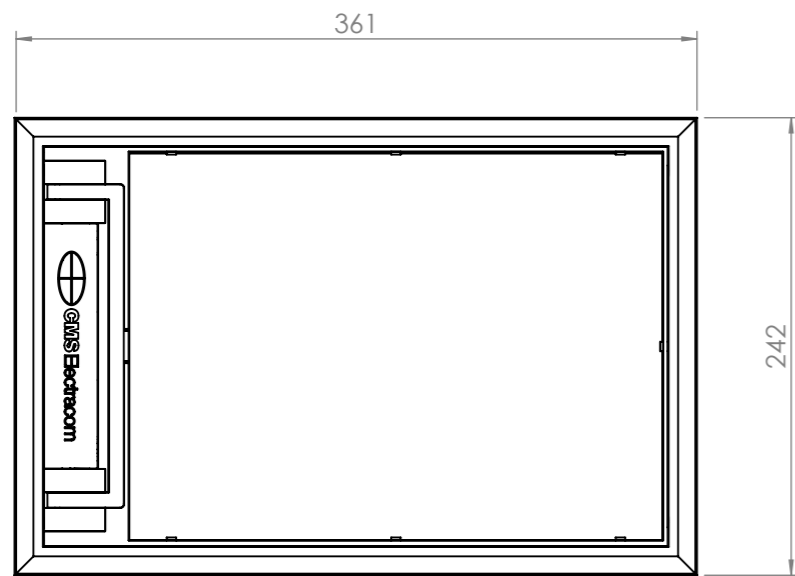

REV	DESCRIPTION	DATE	DRWN	APPV
10	ADDED GAL INSERT PLATE FOR LID	4/02/2019	JC	RG
9	UPDATED SCREWS IN BOM	28/08/2018	JC	AP
8	UPDATED BOM	27/06/2018	JC	AP
7	RELEASED FOR PRODUCTION	22/05/2018	JC	AP
6	RELEASED FOR QUOTATION - NOT FOR PRODUCTION	22/05/2018	JC	AP
REVISIONS				

CUSTOMER SIGNATURE:
MATERIAL: PLASTIC / MS
FINISH: TEXTURED / POWDERCOATED
COLOUR: BLACK SATIN
THIS DRAWING & ASSOCIATED CAD FILES ARE ISSUED IN THE STRICTEST CONFIDENCE AND ARE ONLY TO BE USED IN THE COMMERCIAL INTERESTS OF CMS ELECTRACOM PTY LTD

TOLERANCES UNLESS OTHERWISE STATED:

X ±0.5
 X.X ±0.2
 X.XX ±0.1
 X.XXX ±0.05
 ANG ±0.5°

DRAWN IN mm TO AS1100 DO NOT SCALE



TITLE: CT06GY/BK CENTURY BOX	
DRAWING: LU20298	REV: 10
SCALE 1:4	SHEET 1 OF 2

A3

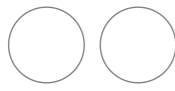

JOB NUMBER
PART NUMBER

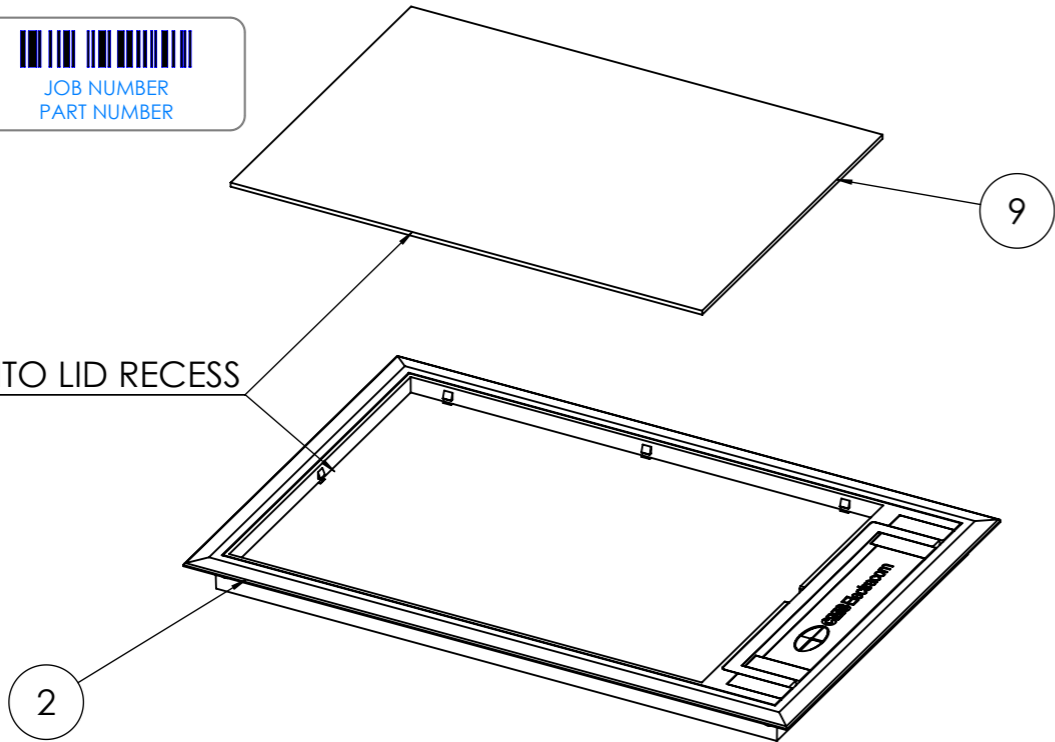

INSERT INTO LID RECESS

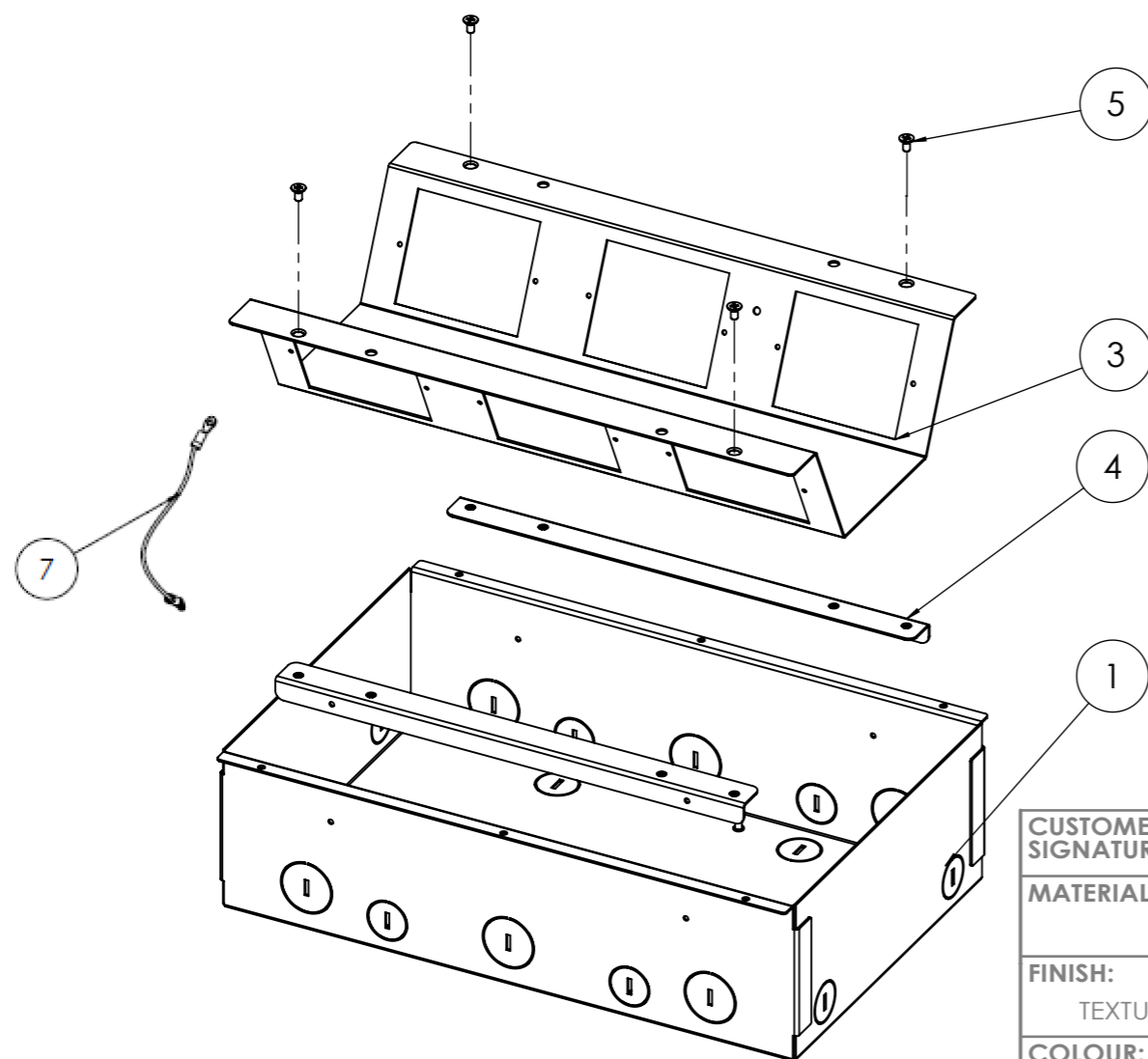

- 6 INCLUDE IN A SACHEL
12x 6G x 1" TYPE B PAN HEAD SELF TAP
- AND
- 8 4x M4 x 20CSK MACHINE SCREW

ITEM NO.	PART NUMBER	QTY.
1	LU20258_FB UNDERCARRIAGE TO SUIT LARGE CENTURY BOX	1
2	FT4 PLASTIC LID	1
3	LU20279_LARGE SIZE FB plate	1
4	LU20265_FB SUPPORT PLATE	2
5	M4 X 8 CSK MACHINE SCREWS	4
6	6G x 1" TYPE B PAN HEAD SELF TAP	12
7	LU9436_150mm EARTH STRAP FROM GPO PLATE TO UNDERCARRIAGE	2
8	M4 x 20 CSK MACHINE SCREW	4
9	LU1345 large gal. insert	1

CUSTOMER SIGNATURE:

MATERIAL: PLASTIC / MS

FINISH: TEXTURED / POWDERCOATED

COLOUR: BLACK SATIN

THIS DRAWING & ASSOCIATED CAD FILES ARE ISSUED IN THE STRICTEST CONFIDENCE AND ARE ONLY TO BE USED IN THE COMMERCIAL INTERESTS OF CMS ELECTRACOM PTY LTD

TOLERANCES UNLESS OTHERWISE STATED:

X ±0.5
 X.X ±0.2
 X.XX ±0.1
 X.XXX ±0.05
 ANG ±0.5°

DRAWN IN mm TO AS1100 DO NOT SCALE



TITLE: CT06GY/BK CENTURY BOX

DRAWING: LU20298

REV: 10

SCALE: 1:4

SHEET: 2 OF 2

SIZE: A3