

30W USB AC MODUAL = U

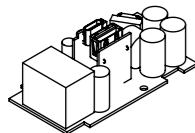

65W USB AC MODUAL = W



AU/NZ SOCKET OUTLET = A

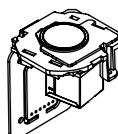

ENGAGE = N  
ENGAGE + RFID = R

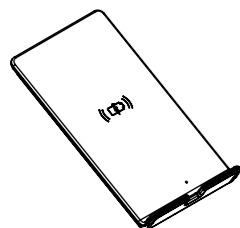

HELISTAND (15W) = P

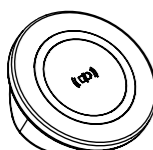

HELIPAD (15W) = J3  
NON-QI2

USE SC\_CMS129\_08 WHEN  
INSTALLING USB

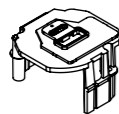

**FACTORY ONLY INSERTABLE MODULES  
REFER PAGE 2 FOR MODULE  
CONFIGURATION**

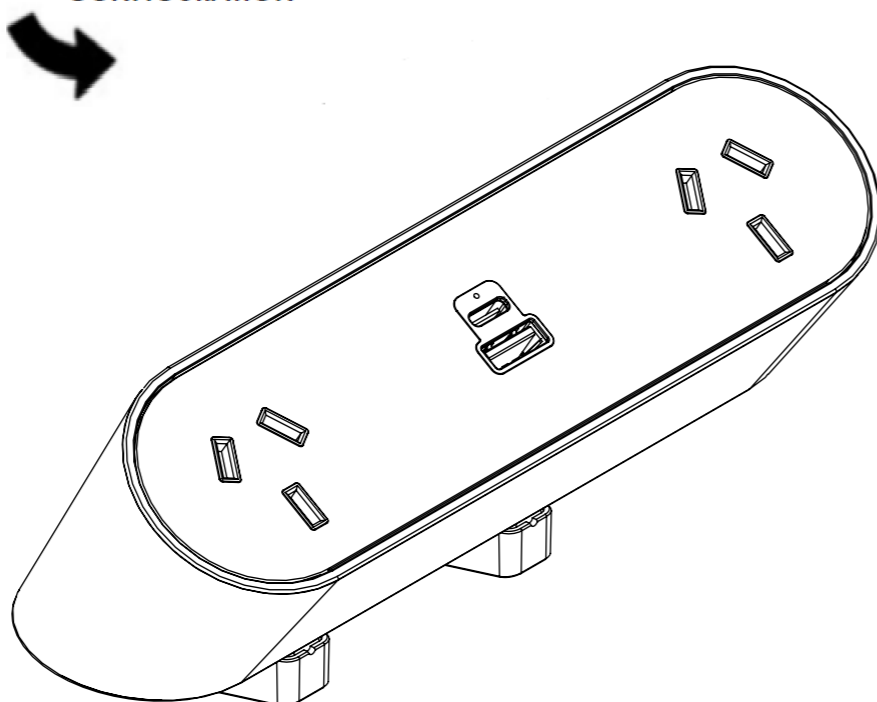

### ABOVE DESK CLAMP

MIN TABLE THICKNESS: 20MM  
MAX TABLE THICKNESS: 32MM

NOTE:  
TABLE SCALLOP OF 40mm **MINIMUM**  
**REQUIRED** WHEN USING HELISTAND &  
PRIVACY SCREEN TO ALLOW ADDITIONAL  
SPACE FOR LARGER PHONES

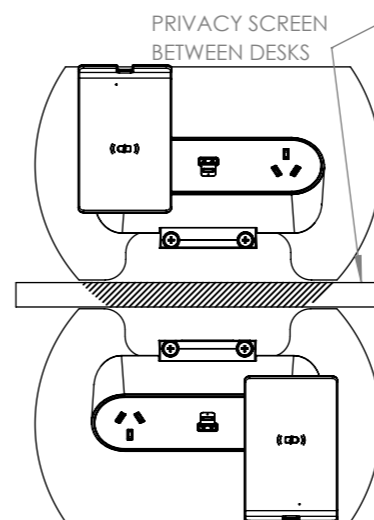

MINIMUM SCALLOP DISTANCE  
TO PRIVACY SCREEN

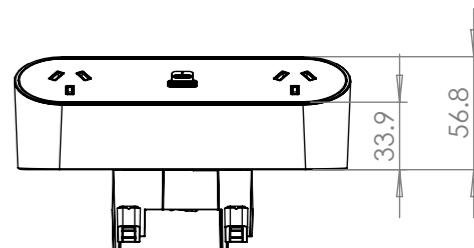
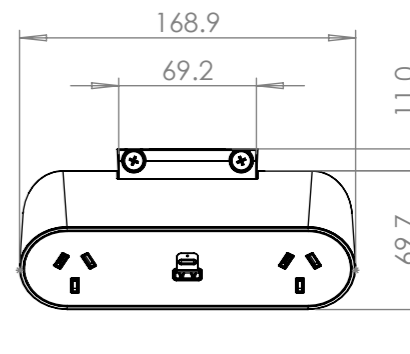
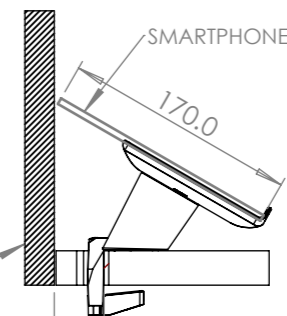
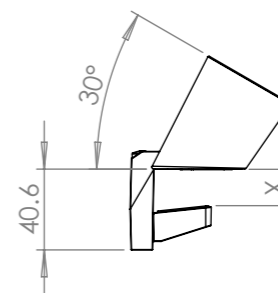

### UNDER DESK CLAMP

COMPATIBLE MOUNTING  
SCREWS: 4G, 6G

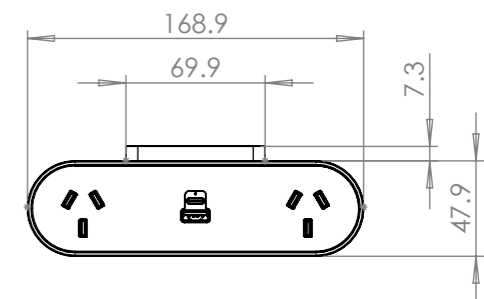
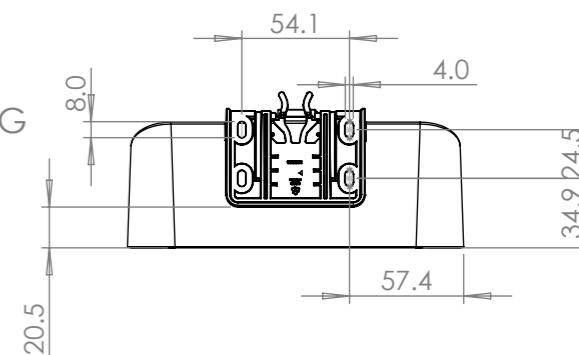
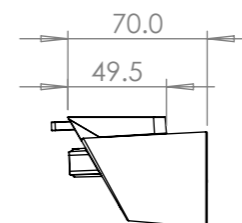

REV	DESCRIPTION	DATE	DRWN	APPV
2	HELIPAD PART CODE UPDATED	28/4/2025	JB	RG
1	RELEASED FOR PRODUCTION	10/4/2025	JB	RG
REVISIONS				

<b>CUSTOMER SIGNATURE:</b>	
<b>MATERIAL:</b>	PC FR
<b>FINISH:</b>	FINE EDM / POLISHED / FABRIC
<b>COLOUR:</b>	REFER TABLE
THIS DRAWING & ASSOCIATED CAD FILES ARE ISSUED IN THE STRICTEST CONFIDENCE AND ARE ONLY TO BE USED IN THE COMMERCIAL INTERESTS OF CMS ELECTRACOM PTY LTD	

TOLERANCES UNLESS OTHERWISE STATED:

X ±0.5  
X.X ±0.2  
X.XX ±0.1  
X.XXX ±0.05  
ANG ±0.5°

DRAWN IN mm TO AS1100 DO NOT SCALE



**CMS Electracom**

COPYRIGHT © 2020

TITLE:

**NOVA TRIO NON-QI2 AU CONFIGURATIONS**

DRAWING:

**LU48246**

REV:

**2**

**A3**

SCALE 1:2

SHEET 1 OF 11

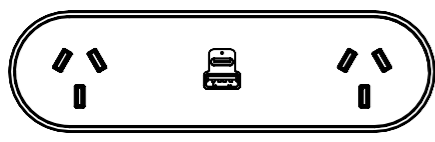

NT\*AUAXxxXX

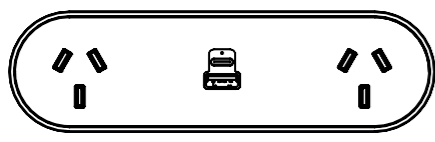

NT\*AWAXxxXX

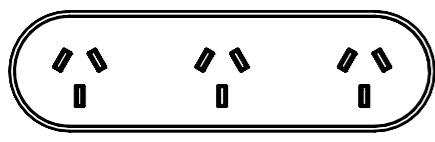

NT\*AAAXxxX

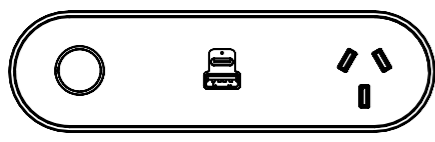

NT\*#UAXxxX  
ABOVE DESK CLAMP ONLY

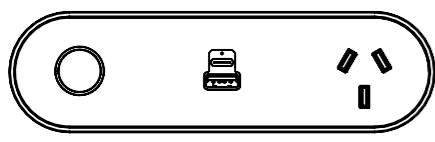

NT\*#WAXxxX  
ABOVE DESK CLAMP ONLY

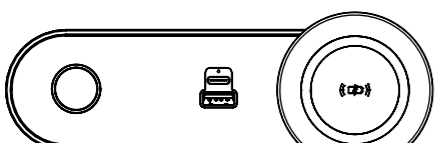

NT\*#UJ3XxxX  
ABOVE DESK CLAMP ONLY

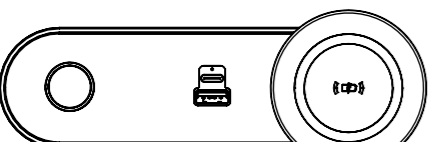

NT\*#WJ3XxxX  
ABOVE DESK CLAMP ONLY

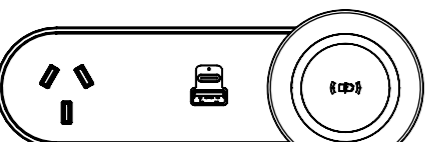

NT\*AUJ3XxxX  
ABOVE DESK CLAMP ONLY

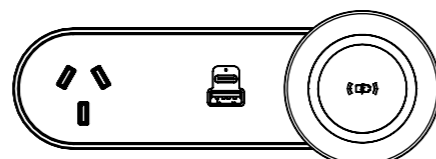

NT\*AWJ3XxxX  
ABOVE DESK CLAMP ONLY

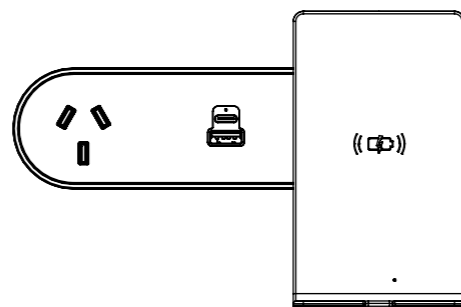

NT\*AUPXxxXX  
ABOVE DESK CLAMP ONLY

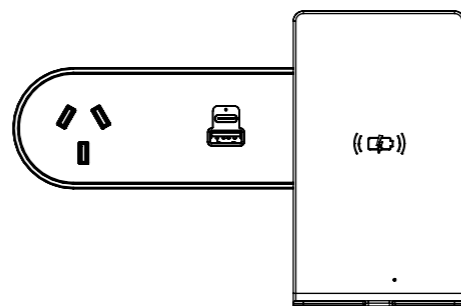

NT\*AWPXxxXX  
ABOVE DESK CLAMP ONLY

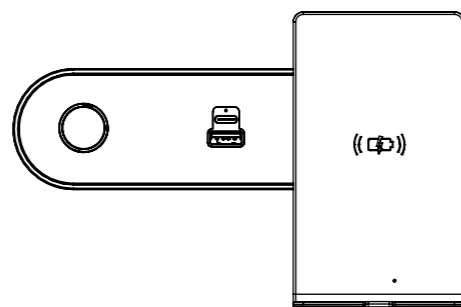

NT\*#UPXxxXX  
ABOVE DESK CLAMP ONLY

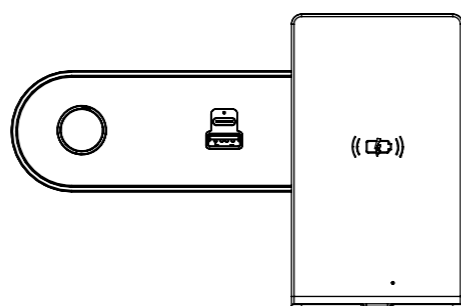

NT\*#WPXxxXX  
ABOVE DESK CLAMP ONLY

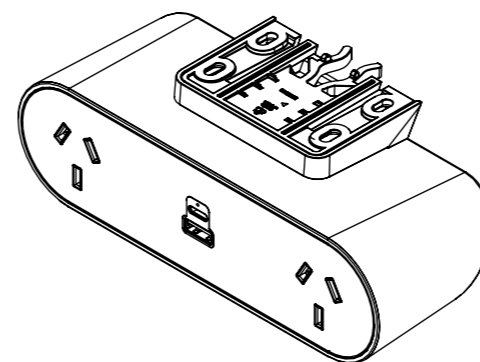

Z = UNDER DESK CLAMP

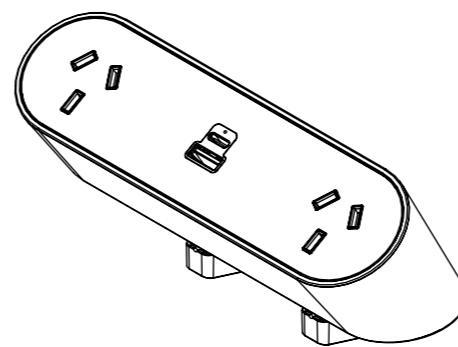

S = ABOVE DESK CLAMP

NOTE:

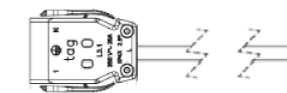

CABLE TYPE: 3 CORE x 2.5mm<sup>2</sup>  
DESCRIPTION: TAG CONNECTOR LEAD  
COLOUR: WHITE OR BLACK  
(REFER TO PURCHASE ORDER)

xx	LENGTH (mm)
05	500
10	1000
15	1500
20	2000
25	2500
30	3000
35	3500
40	4000
45	4500
50	5000

NOTE:

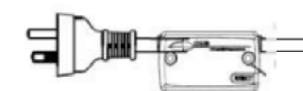

CABLE TYPE: 3 CORE x 1.0mm<sup>2</sup>  
DESCRIPTION: AUSTRALIAN PLUG LEAD  
WITH THERMAL OVERLOAD  
COLOUR: WHITE OR BLACK  
(REFER TO PURCHASE ORDER)

xx	LENGTH (mm)
05	500
10	1000
15	1500
20	2000
25	2500
30	3000
35	3500
40	4000
45	4500
50	5000

COLOUR VARIATIONS	
PART NUMBER	DESCRIPTION
W	WHITE BODY & CLAMP
B	BLACK BODY & CLAMP
1	WHITE DECAL GLOSS
2	WHITE DECAL MATT
3	BLACK DECAL GLOSS
4	BLACK DECAL MATT
FABRIC FINISH REFER TO LU40741	
A	FABRIC COLOUR 1 - VANILA
B	FABRIC COLOUR 2 - SMOKE
C	FABRIC COLOUR 3 - IRON FORMERLY KNOWN AS CHARCOAL
D	FABRIC COLOUR 4 - CHARCOAL FORMERLY KNOWN AS BLACK

**PART NUMBER:** (REFER CONFIGURATION)XxxXX  
NOTE - \* - CLAMP TYPE - (S = ABOVE DESK OR Z = UNDER DESK)  
# - ENAGE (N = ENGAGE OR R = ENGAGE + RFID)  
X - LEAD TYPE (TAG = T OR 3PIN PLUG = I)  
xx - LENGTH - 05 / 10 / 15 / 20 / 25 / 30 / 35 / 40 / 45 / 50  
XX - COLOUR - W / B + 1 / 2 / 3 / 4 +(OPTIONAL) A / B / C / D

CUSTOMER SIGNATURE:	TOLERANCES UNLESS OTHERWISE STATED:
MATERIAL: PC FR	X ±0.5 X.X ±0.2 X.XX ±0.1 X.XXX ±0.05 ANG ±0.5°
FINISH: FINE EDM / POLISHED / FABRIC	
COLOUR: REFER TABLE	
THIS DRAWING & ASSOCIATED CAD FILES ARE ISSUED IN THE STRICTEST CONFIDENCE AND ARE ONLY TO BE USED IN THE COMMERCIAL INTERESTS OF CMS ELECTRACOM PTY LTD	DRAWN IN mm TO AS1100 DO NOT SCALE

 **CMS Electracom** COPYRIGHT © 2020

TITLE: **NOVA TRIO NON-QI2 AU CONFIGURATIONS**

DRAWING: **LU48246** REV: **2** **A3**

SCALE 1:2 SHEET 2 OF 11