

30W USB AC MODUAL = U

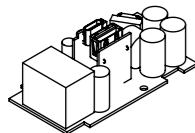

65W USB AC MODUAL = W



AU/NZ SOCKET OUTLET = A

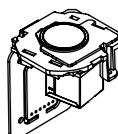

ENGAGE = N
ENGAGE + RFID = R



HELISTAND (15W) WIRELESS CHARGER = P

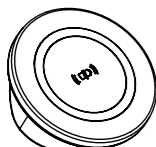

HELIPAD (15W) MAGNETIC WIRELESS CHARGER = J3

USE SC_CMS129_08 WHEN INSTALLING USB

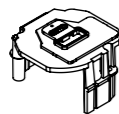

**FACTORY ONLY INSERTABLE MODULES
REFER PAGE 2 FOR MODULE
CONFIGURATION**

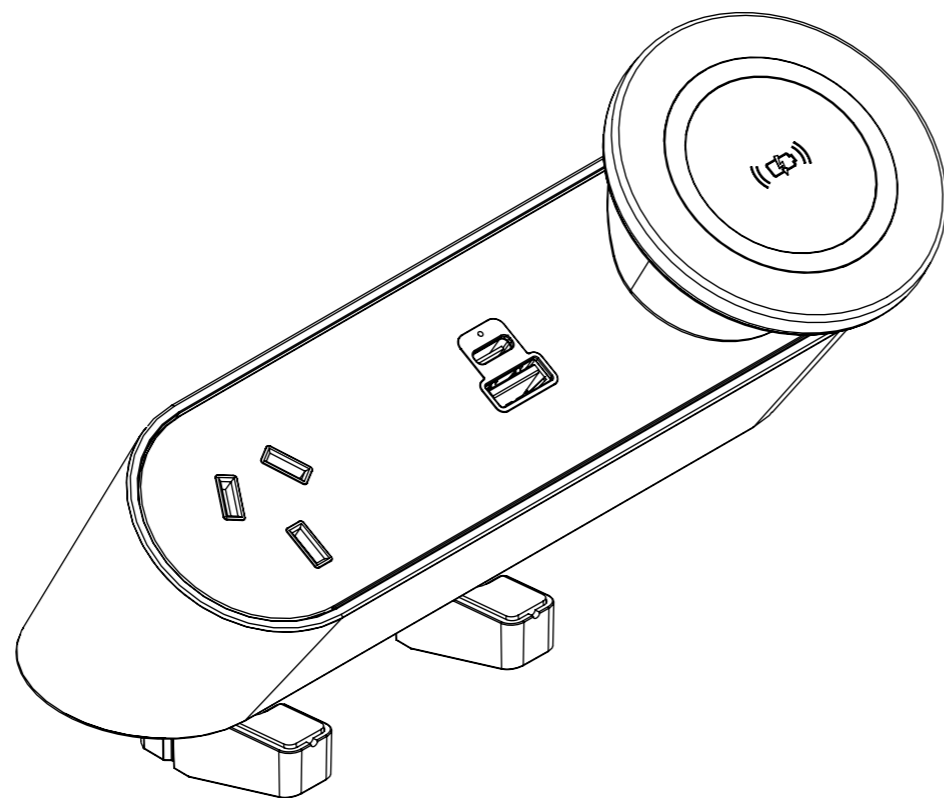

ABOVE DESK CLAMP

MIN TABLE THICKNESS: 20MM
MAX TABLE THICKNESS: 32MM

NOTE:
TABLE SCALLOP OF 40mm **MINIMUM**
REQUIRED WHEN USING HELISTAND &
PRIVACY SCREEN TO ALLOW ADDITIONAL
SPACE FOR LARGER PHONES

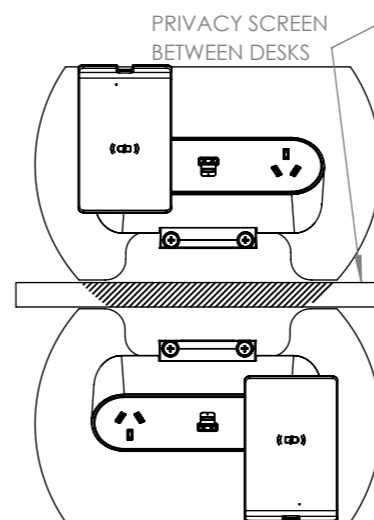

MINIMUM SCALLOP DISTANCE
TO PRIVACY SCREEN

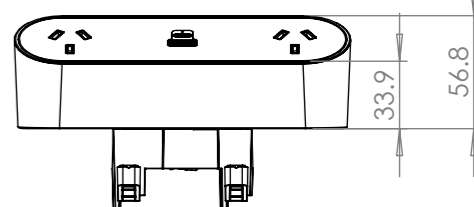
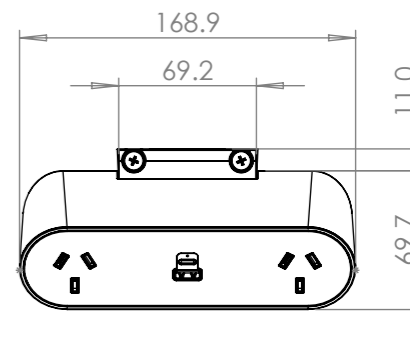
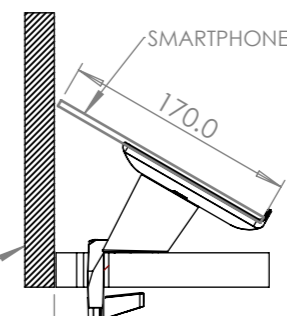
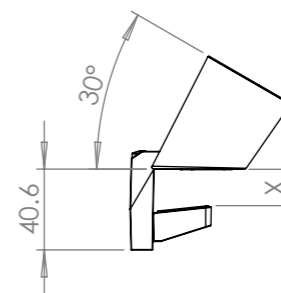

UNDER DESK CLAMP

COMPATIBLE MOUNTING
SCREWS: 4G, 6G

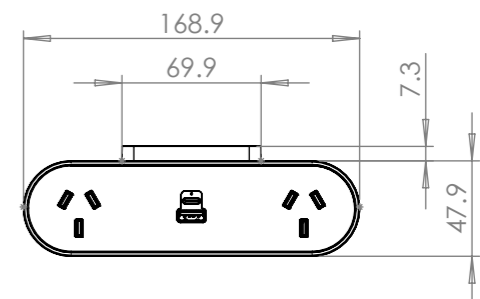
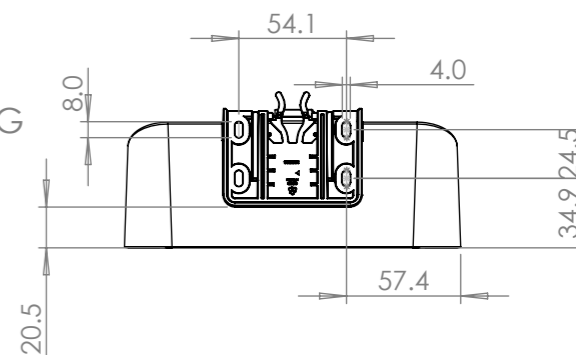
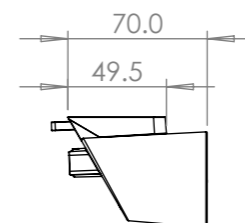

REV	DESCRIPTION	DATE	DRWN	APPV
4	TITLE UPDTAED, COLOUR TABLE UPDATED	30/6/2025	JB	RG
3	STAINLESS DECALS ADDED	2/6/2025	JB	RG
2	HELIPAD PART CODE UPDATED	28/4/2025	JB	RG
1	RELEASED FOR PRODUCTION	10/4/2025	JB	RG
REVISIONS				

CUSTOMER SIGNATURE:
MATERIAL: PC FR
FINISH: FINE EDM / POLISHED / FABRIC
COLOUR: REFER TABLE
THIS DRAWING & ASSOCIATED CAD FILES ARE ISSUED IN THE STRICTEST CONFIDENCE AND ARE ONLY TO BE USED IN THE COMMERCIAL INTERESTS OF CMS ELECTRACOM PTY LTD

TOLERANCES UNLESS OTHERWISE STATED:

X ±0.5
X.X ±0.2
X.XX ±0.1
X.XXX ±0.05
ANG ±0.5°

DRAWN IN mm TO AS1100 DO NOT SCALE



CMS Electracom

COPYRIGHT © 2020

TITLE:
NOVA TRIO AU MAGNETIC WIRELESS CHARGER CONFIGURATIONS

DRAWING:
LU48246

REV:
4 **A3**

SCALE 1:2

SHEET 1 OF 11

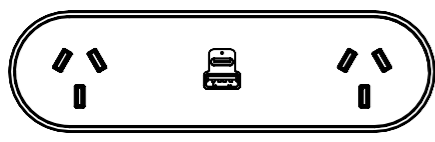

NT*AUAXxxXX

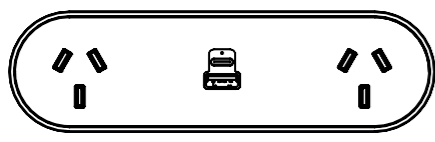

NT*AWAXxxXX

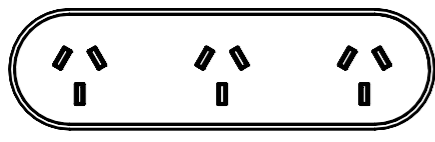

NT*AAAXxxX

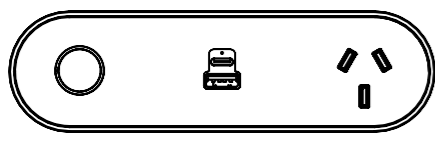

NT*#UAXxxX

ABOVE DESK CLAMP ONLY

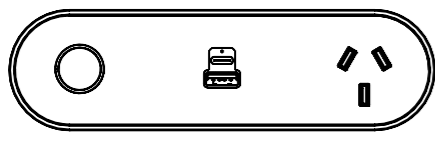

NT*#WAXxxX

ABOVE DESK CLAMP ONLY

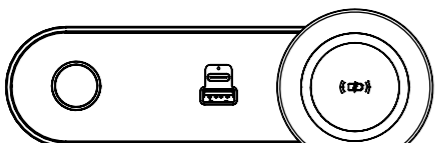

NT*#UJ3XxxX

ABOVE DESK CLAMP ONLY

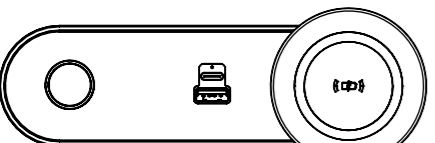

NT*#WJ3XxxX

ABOVE DESK CLAMP ONLY

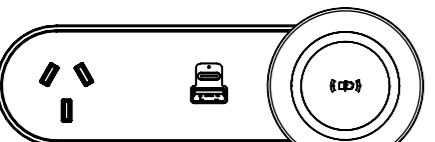

NT*AUJ3XxxX

ABOVE DESK CLAMP ONLY

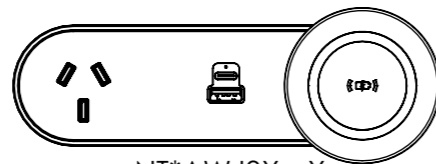

NT*AWJ3XxxX

ABOVE DESK CLAMP ONLY

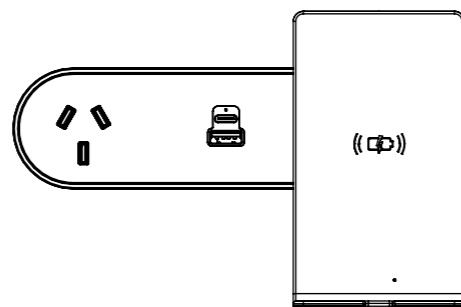

NT*AUPXxxXX

ABOVE DESK CLAMP ONLY

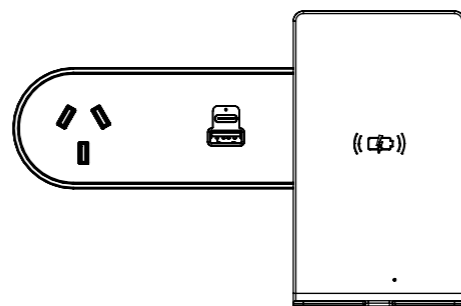

NT*AWPXxxXX

ABOVE DESK CLAMP ONLY

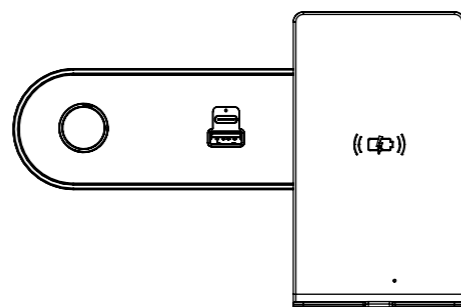

NT*#UPXxxXX

ABOVE DESK CLAMP ONLY

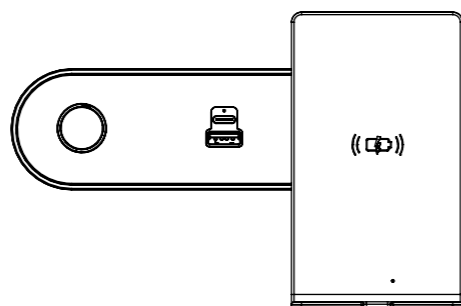

NT*#WPXxxXX

ABOVE DESK CLAMP ONLY

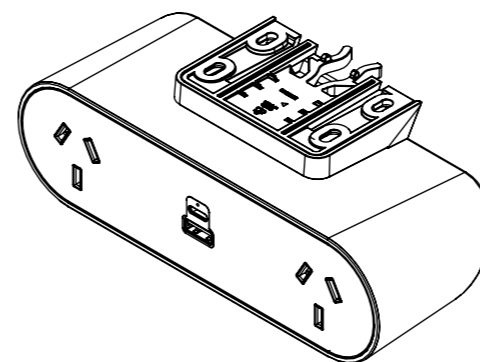

Z = UNDER DESK CLAMP

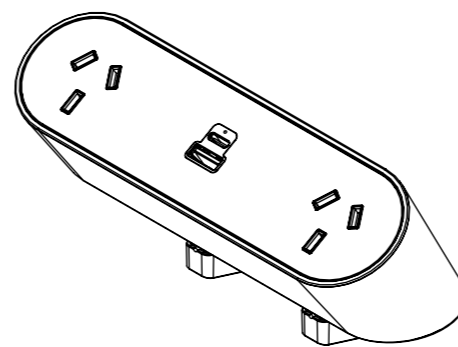

S = ABOVE DESK CLAMP

NOTE:

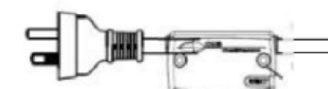

CABLE TYPE: 3 CORE x 1.0mm²
DESCRIPTION: AUSTRALIAN PLUG LEAD WITH THERMAL OVERLOAD

COLOUR: WHITE OR BLACK (REFER TO PURCHASE ORDER)
LENGTH (mm):

xx	LENGTH (mm)
05	500
10	1000
15	1500
20	2000
25	2500
30	3000
35	3500
40	4000
45	4500
50	5000

NOTE:

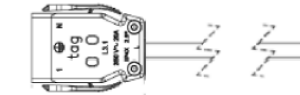

CABLE TYPE: 3 CORE x 2.5mm²
DESCRIPTION: TAG CONNECTOR LEAD
COLOUR: WHITE OR BLACK (REFER TO PURCHASE ORDER)

LENGTH (mm):

xx	LENGTH (mm)
05	500
10	1000
15	1500
20	2000
25	2500
30	3000
35	3500
40	4000
45	4500
50	5000

COLOUR VARIATIONS

PART NUMBER	DESCRIPTION
W	WHITE BODY & CLAMP
B	BLACK BODY & CLAMP
1	WHITE DECAL GLOSS
2	WHITE DECAL MATT
3	BLACK DECAL GLOSS
4	BLACK DECAL MATT
LUX DECAL OPTIONS	
BSB	PRESTIGE GOLD, SATIN (BRUSHED)
BZB	QUARTZ BRONZE SATIN (BRUSHED)
SSB	STAINLESS STEEL NO.4 (BRUSHED)
BSM	PRESTIGE GOLD GRANEX (MATTE)
BZM	QUARTZ BRONZE GRANEX (MATTE)
SSM	NATURAL GRANEX (MATTE)
BKM	BLACK GRANEX (MATTE)
FABRIC FINISH REFER TO LU38547	
A	FABRIC COLOUR 1 - VANILA
B	FABRIC COLOUR 2 - SMOKE
C	FABRIC COLOUR 3 - IRON FORMERLY KNOWN AS CHARCOAL
D	FABRIC COLOUR 4 - CHARCOAL FORMERLY KNOWN AS BLACK

PART NUMBER: (REFER CONFIGURATION)XxxXX

NOTE - * - CLAMP TYPE - (S = ABOVE DESK OR Z = UNDER DESK)

- ENAGE (N = ENGAGE OR R = ENGAGE + RFID)

X - LEAD TYPE (TAG = T OR 3PIN PLUG = I)

xx - LENGTH - 05 / 10 / 15 / 20 / 25 / 30 / 35 / 40 / 45 / 50

XX - COLOUR - W / B + 1 / 2 / 3 / 4 +(OPTIONAL) A / B / C / D

CUSTOMER SIGNATURE:	TOLERANCES UNLESS OTHERWISE STATED:		COPYRIGHT © 2020	
MATERIAL: PC FR	X ±0.5 X.X ±0.2 X.XX ±0.1 X.XXX ±0.05 ANG ±0.5°		TITLE: NOVA TRIO AU MAGNETIC WIRELESS CHARGER CONFIGURATIONS	
FINISH: FINE EDM / POLISHED / FABRIC	COLOUR: REFER TABLE	DRAWING: LU48246	REV: 4	A3
THIS DRAWING & ASSOCIATED CAD FILES ARE ISSUED IN THE STRICTEST CONFIDENCE AND ARE ONLY TO BE USED IN THE COMMERCIAL INTERESTS OF CMS ELECTRACOM PTY LTD		DRAWN IN mm TO AS1100 DO NOT SCALE	SCALE 1:2	