

USE SC_CMS129_08 WHEN
INSTALLING USB

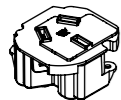

USB AC MODUAL = U



AU/NZ SOCKET OUTLET = A

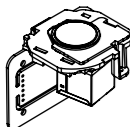

ENGAGE = N
ENGAGE + RFID = R

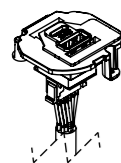

100W USB AC = V
118W USB AC = Q
140W USB AC = Y

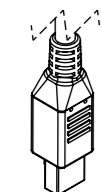

HELIPAD (15W) = J3
NON-Q12



HELIPAD (15W) = J3
NON-Q12

**FACTORY ONLY INSERTABLE MODULES
REFER PAGE 2 FOR MODULE
CONFIGURATION**

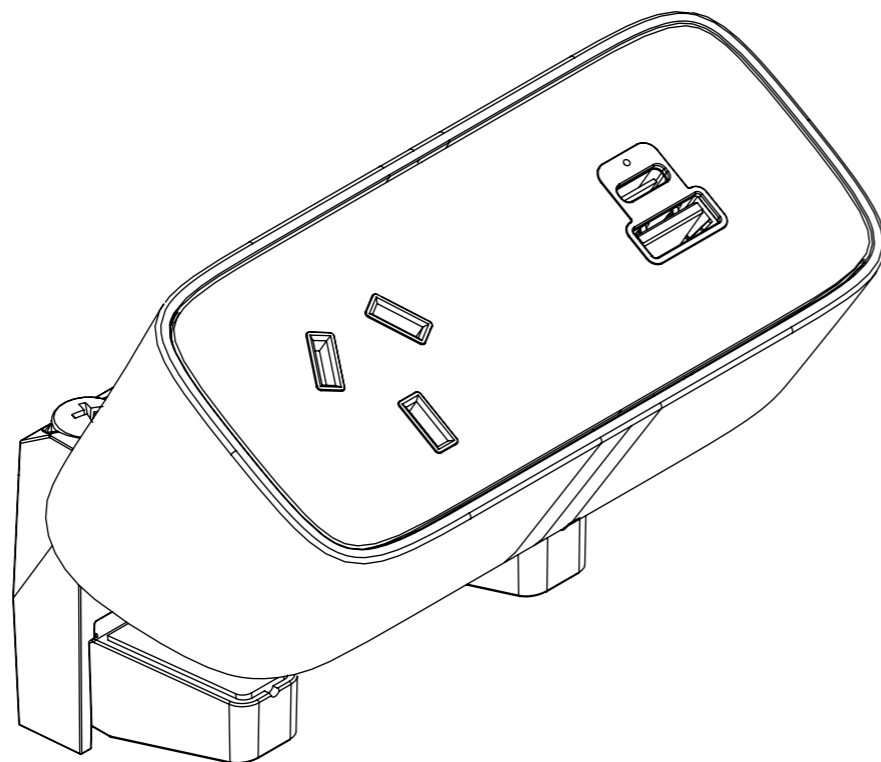

ABOVE DESK CLAMP

MIN TABLE THICKNESS: 20MM
MAX TABLE THICKNESS 32MM

NOTE:
TABLE SCALLOP OF 40mm MINIMUM
REQUIRED WHEN USING HELISTAND &
PRIVACY SCREEN TO ALLOW ADDITIONAL
SPACE FOR LARGE PHONES

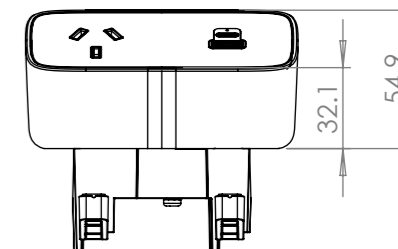
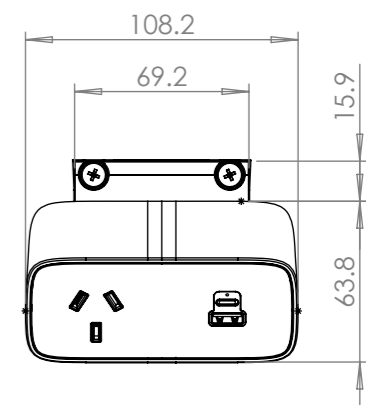
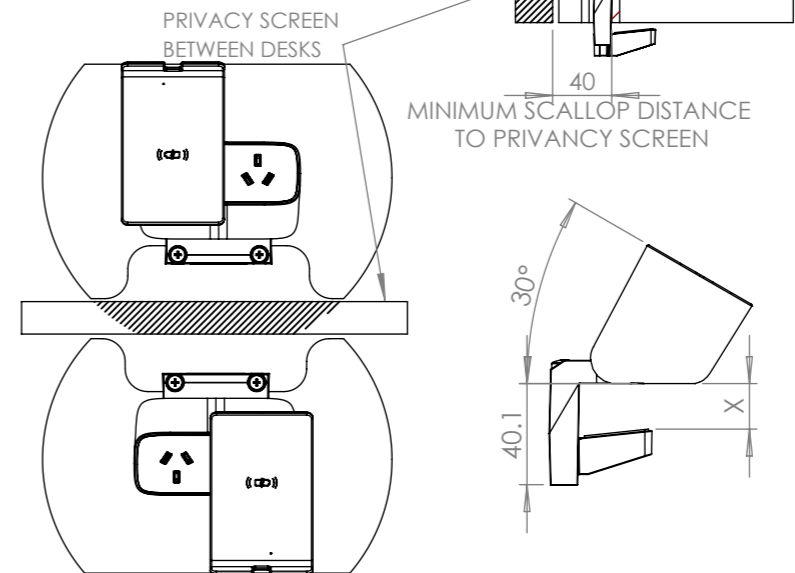

UNDER DESK CLAMP

COMPATIBLE MOUNTING
SCREWS: 4G, 6G

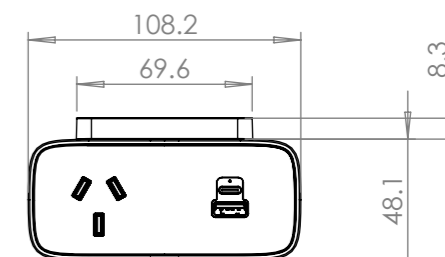
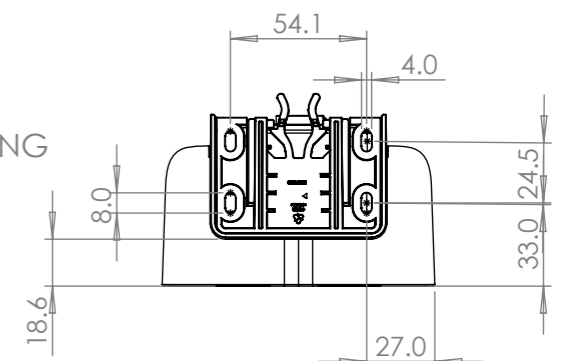
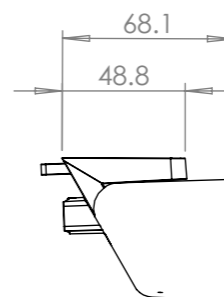

1	RELEASED FOR PRODUCTION	5/5/2025	JB	RG
REV	DESCRIPTION	DATE	DRWN	APPV
REVISIONS				

CUSTOMER SIGNATURE:	
MATERIAL:	PC FR
FINISH:	FINE EDM / POLISHED / FABRIC
COLOUR:	REFER TABLE
THIS DRAWING & ASSOCIATED CAD FILES ARE ISSUED IN THE STRICTEST CONFIDENCE AND ARE ONLY TO BE USED IN THE COMMERCIAL INTERESTS OF CMS ELECTRACOM PTY LTD	

TOLERANCES UNLESS OTHERWISE STATED:
X ±0.5
X.X ±0.2
X.XX ±0.1
X.XXX ±0.05
ANG ±0.5°
DRAWN IN mm TO AS1100 DO NOT SCALE

 **CMS Electracom** COPYRIGHT © 2020

TITLE: VIVA DUO NON-Q12 AU CONFIGURATIONS

DRAWING: LU48340 **REV:** 1 **A3**

SCALE 1:2 SHEET 1 OF 12

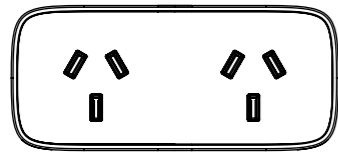

VD*AAxXX

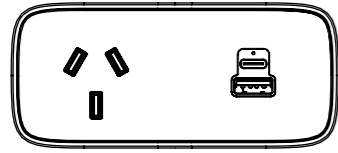

VD*AUXxxXX

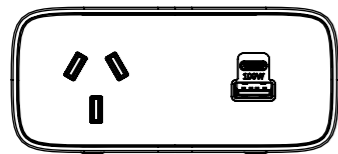

VD*A1XxxXX

ONLY AVAILABLE IN ABOVE DESK CLAMP

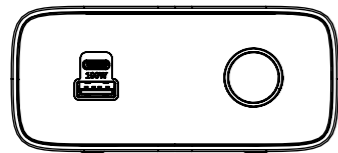

VD*1#XxxXX

ONLY AVAILABLE IN ABOVE DESK CLAMP

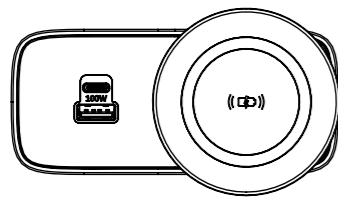

VD*1J3XxxXX

ONLY AVAILABLE IN ABOVE DESK CLAMP

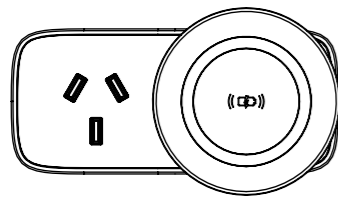

VD*AJ3XxxXX

ONLY AVAILABLE IN ABOVE DESK CLAMP

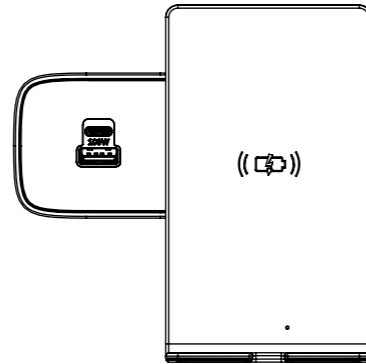

VD*1PXxxXX

ONLY AVAILABLE IN ABOVE DESK CLAMP

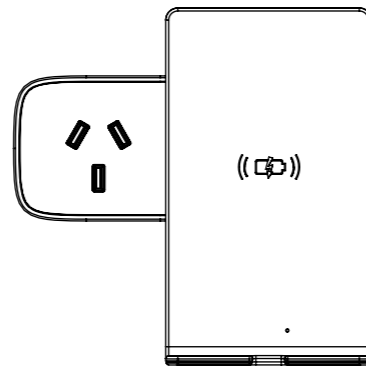

VD*APXxxXX

ONLY AVAILABLE IN ABOVE DESK CLAMP

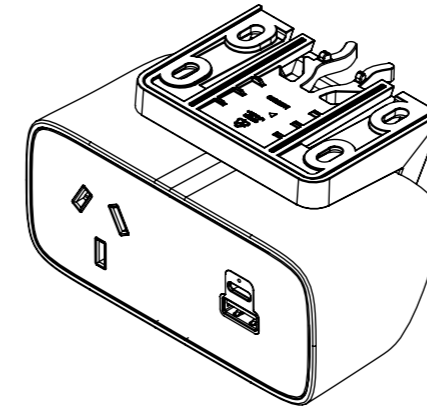

Z = UNDER DESK CLAMP

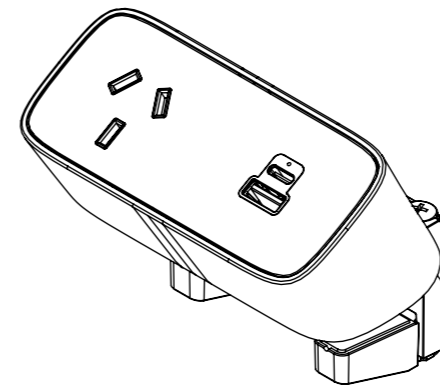

S = ABOVE DESK CLAMP

NOTE:

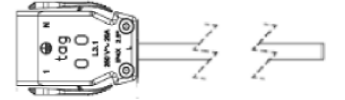

CABLE TYPE: 3 CORE x 2.5mm²
DESCRIPTION: TAG CONNECTOR LEAD
COLOUR: WHITE OR BLACK
(REFER TO PURCHASE ORDER)
LENGTH (mm):

xx	LENGTH (mm)
05	500
10	1000
15	1500
20	2000
25	2500
30	3000
35	3500
40	4000
45	4500
50	5000

NOTE:

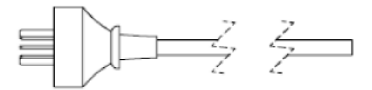

CABLE TYPE: 3 CORE x 1.0mm²
DESCRIPTION: AUSTRALIAN PLUG LEAD
COLOUR: WHITE OR BLACK
(REFER TO PURCHASE ORDER)
LENGTH (mm):

xx	LENGTH (mm)
05	500
10	1000
15	1500
20	2000
25	2500
30	3000
35	3500
40	4000
45	4500
50	5000

COLOUR VARIATIONS	
PART NUMBER	DESCRIPTION
W	WHITE BODY & CLAMP
B	BLACK BODY & CLAMP
1	WHITE DECAL GLOSS
2	WHITE DECAL MATT
3	BLACK DECAL GLOSS
4	BLACK DECAL MATT
FABRIC FINISH REFER TO LU40741	
A	FABRIC COLOUR 1 - VANILA
B	FABRIC COLOUR 2 - SMOKE
C	FABRIC COLOUR 3 - IRON FORMERLY KNOWN AS CHARCOAL
D	FABRIC COLOUR 4 - CHARCOAL FORMERLY KNOWN AS BLACK

PART NUMBER: (REFER CONFIGURATION)xxXX

NOTE - * - CLAMP TYPE - (S = ABOVE DESK OR Z = UNDER DESK)

- ENGAGE (N = ENGAGE OR R = ENGAGE + RFID)

1- USB (V = 100W USB AC OR Q = 118 USB AC OR Y = 140W USB AC)

X - LEAD TYPE (TAG = T OR 3PIN PLUG = I)

xx - LENGTH - 05 / 10 / 15 / 20 / 25 / 30 / 35 / 40 / 45 / 50

XX - COLOUR - W / B + 1 / 2 / 3 / 4 + (OPTIONAL) A / B / C / D

CUSTOMER SIGNATURE:	TOLERANCES UNLESS OTHERWISE STATED:
MATERIAL: PC FR	X ±0.5 X.X ±0.2 X.XX ±0.1 X.XXX ±0.05 ANG ±0.5°
FINISH: FINE EDM / POLISHED / FABRIC	
COLOUR: REFER TABLE	
THIS DRAWING & ASSOCIATED CAD FILES ARE ISSUED IN THE STRICTEST CONFIDENCE AND ARE ONLY TO BE USED IN THE COMMERCIAL INTERESTS OF CMS ELECTRACOM PTY LTD	DRAWN IN mm TO AS1100 DO NOT SCALE



TITLE:
VIVA DUO NON-Q12 AU CONFIGURATIONS

DRAWING: LU48340	REV: 1	A3
SCALE 1:2	SHEET 2 OF 12	