

USE SC_CMS131_11
WHEN INSTALLING USB

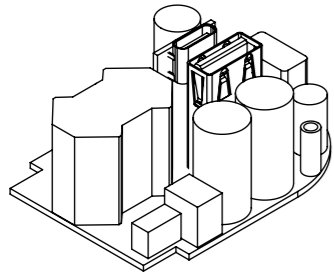

30W USB AC MODUAL = U

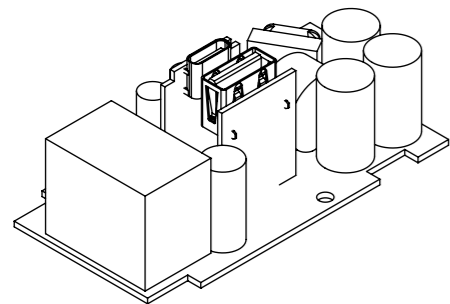
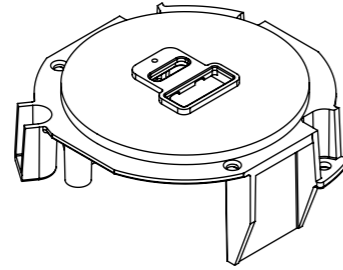

65W USB AC MODUAL = W

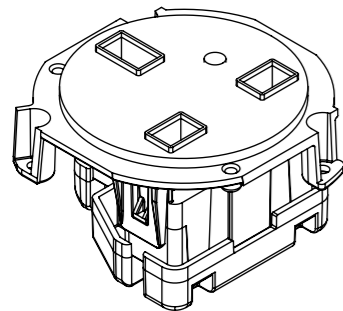

UK FUSED OUTLET = B

**FACTORY ONLY INSERTABLE MODULES
REFER PAGE 2 FOR MODULE
CONFIGURATION**

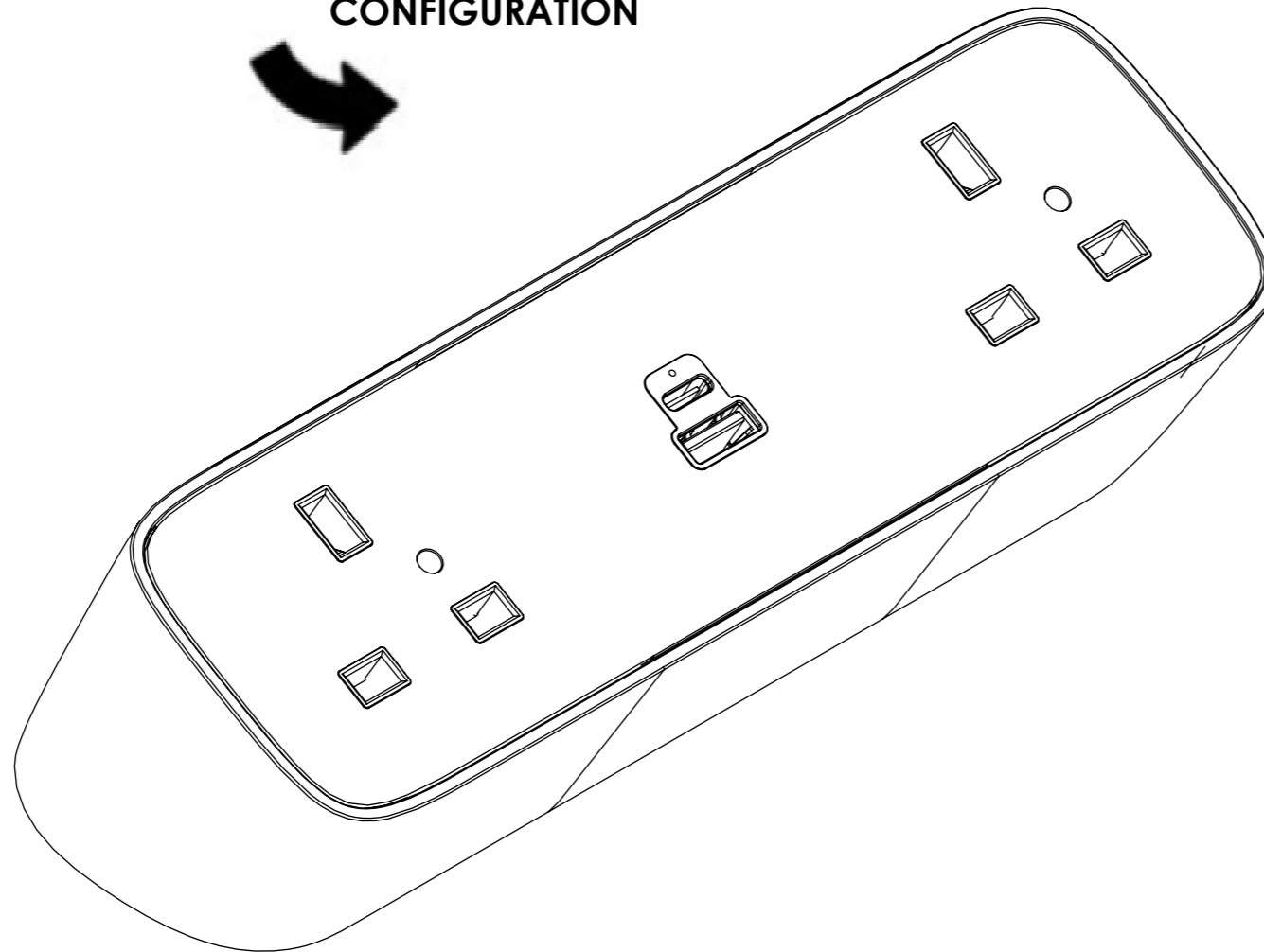

ABOVE DESK CLAMP

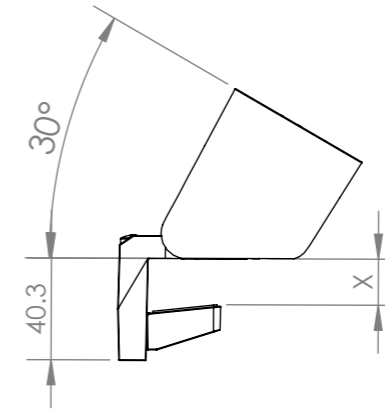
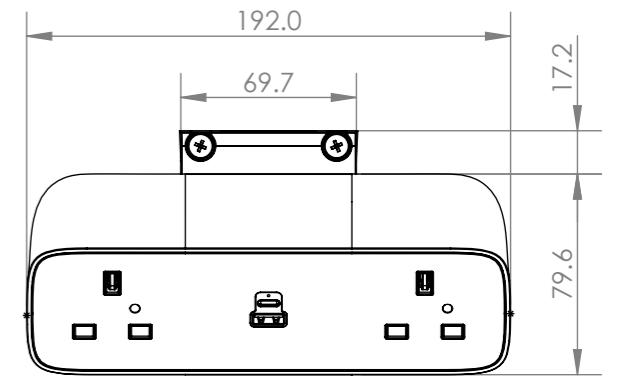

MIN TABLE THICKNESS: 20MM
MAX TABLE THICKNESS 32MM

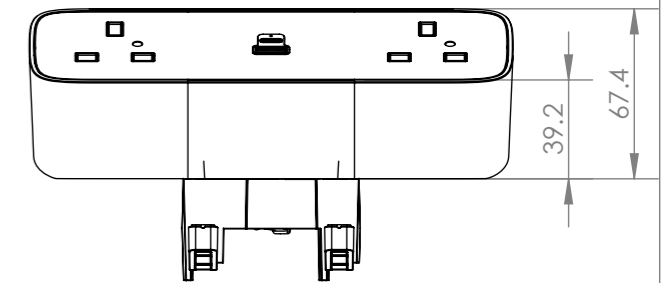

UNDER DESK CLAMP

COMPATIBLE MOUNTING
SCREWS: 4G, 6G

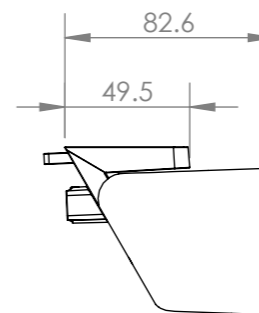
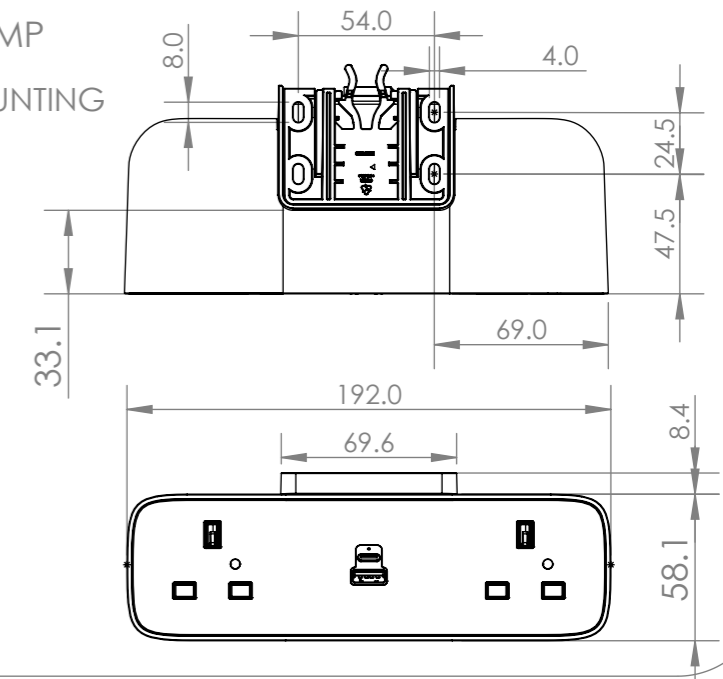

CUSTOMER
SIGNATURE:

MATERIAL: PC FR

FINISH: FINE EDM / POLISHED /
FABRIC

COLOUR: REFER TABLE

TOLERANCES UNLESS
OTHERWISE STATED:

X ±0.5
X.X ±0.2
X.XX ±0.1
X.XXX ±0.05
ANG ±0.5°



CMS Electracom COPYRIGHT
© 2020

TITLE:

VIVA TRIO XL UK CONFIGURATIONS

DRAWING:

LU39702

REV:

2

A3

THIS DRAWING & ASSOCIATED CAD FILES ARE
ISSUED IN THE STRICTEST CONFIDENCE AND
ARE ONLY TO BE USED IN THE COMMERCIAL
INTERESTS OF CMS ELECTRACOM PTY LTD

DRAWN IN mm
TO AS1100
DO NOT SCALE



SCALE 1:2

SHEET 1 OF 4

REV	DESCRIPTION	DATE	DRWN	APPV
2	SCREW NOTE ADDED FOR USE OF TYPE 25 OR TYPE B	29/7/2022	JB	RG
1	RELEASED FOR PRODUCTION	7/5/2021	JB	RG
REVISIONS				

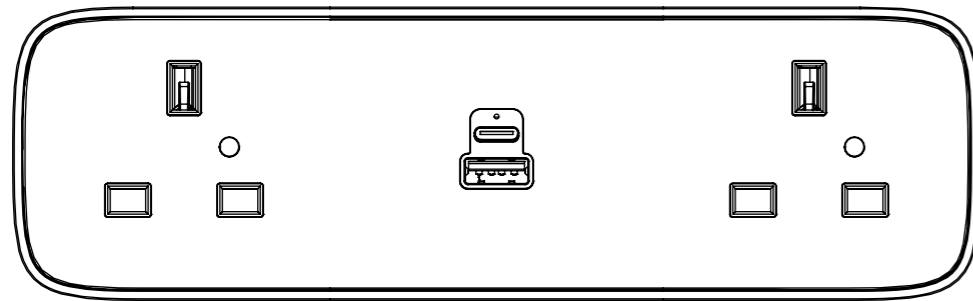

VT*BUBXxxXX

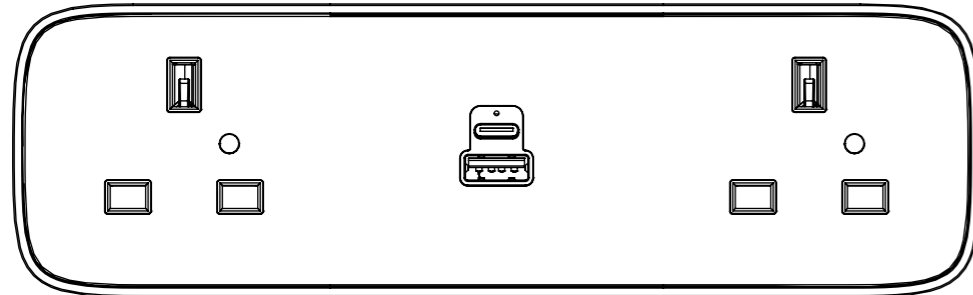

VT*BWBXxxXX

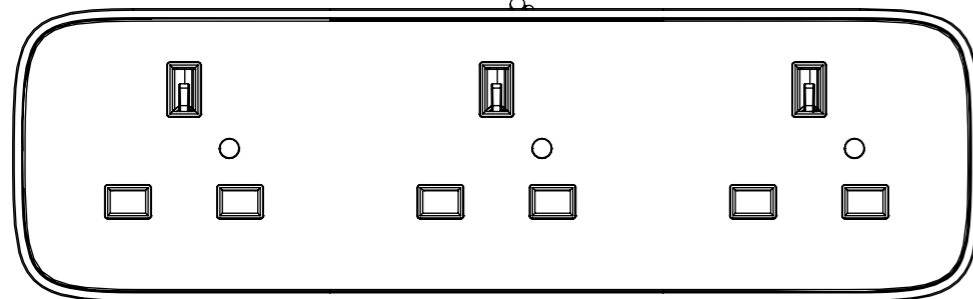

VT*BBBXxxXX

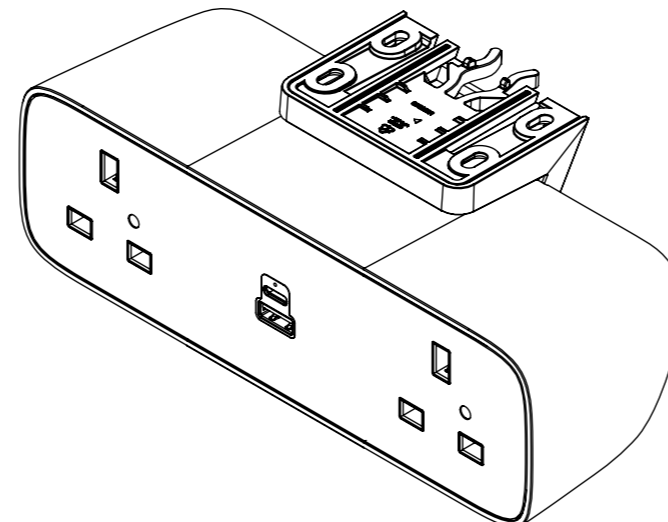

Z = UNDER DESK CLAMP

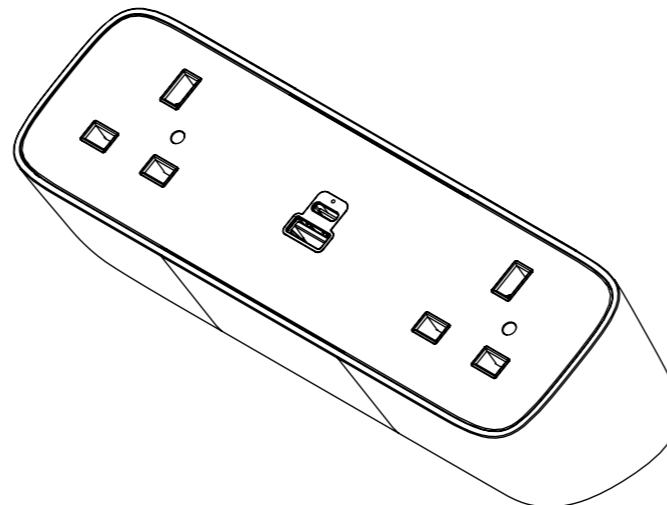

S= ABOVE DESK CLAMP

NOTE:

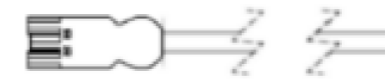

CABLE TYPE: 3 CORE x 1.5mm²
 DESCRIPTION: GST PLUG LEAD
 COLOUR: WHITE OR BLACK
 (REFER TO PURCHASE ORDER)
 LENGTH (mm):

xx	LENGTH (mm)
05	500
10	1000
15	1500
20	2000
25	2500
30	3000
35	3500
40	4000
45	4500
50	5000

NOTE:

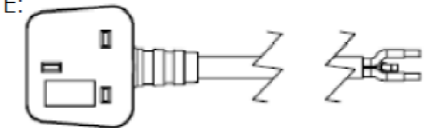

CABLE TYPE: 3 CORE x 1.5mm²
 DESCRIPTION: BRITISH 13A PLUG LEAD
 COLOUR: WHITE OR BLACK
 (REFER TO PURCHASE ORDER)
 LENGTH (mm):

xx	LENGTH (mm)
05	500
10	1000
15	1500
20	2000
25	2500
30	3000
35	3500
40	4000
45	4500
50	5000

COLOUR VARIATIONS	
PART NUMBER	DESCRIPTION
W	WHITE BODY & CLAMP
B	BLACK BODY & CLAMP
1	WHITE DECAL GLOSS
2	WHITE DECAL MATT
3	BLACK DECAL GLOSS
4	BLACK DECAL MATT
FABRIC FINISH REFER TO LU38547	
A	FABRIC COLOUR 1
B	FABRIC COLOUR 2
C	FABRIC COLOUR 3
D	FABRIC COLOUR 4

PART NUMBER: (REFER CONFIGURATION)xxXX
 NOTE - * - CLAMP TYPE - (S = ABOVE DESK OR Z = UNDER DESK)
 X - LEAD TYPE (BS PLUG = B), (GST CONNECTOR = W)
 xx - LENGTH - 05 / 10 / 15 / 20 / 25 / 30 / 35 / 40 / 45 / 50
 XX - COLOUR - W / B + 1 / 2 / 3 / 4 + (OPTIONAL) A / B / C / D

CUSTOMER SIGNATURE:	TOLERANCES UNLESS OTHERWISE STATED: X ±0.5 X.X ±0.2 X.XX ±0.1 X.XXX ±0.05 ANG ±0.5°	 CMS Electracom <small>COPYRIGHT © 2020</small>	
MATERIAL: PC FR			TITLE: VIVA TRIO XL UK CONFIGURATIONS
FINISH: FINE EDM / POLISHED / FABRIC		DRAWING: LU39702	REV: 2
COLOUR: REFER TABLE		SCALE: 1:2	REV: 2
THIS DRAWING & ASSOCIATED CAD FILES ARE ISSUED IN THE STRICTEST CONFIDENCE AND ARE ONLY TO BE USED IN THE COMMERCIAL INTERESTS OF CMS ELECTRACOM PTY LTD	DRAWN IN mm TO AS1100 DO NOT SCALE	A3 SHEET 2 OF 4	