

USE SC_CMS131_11
WHEN INSTALLING USB

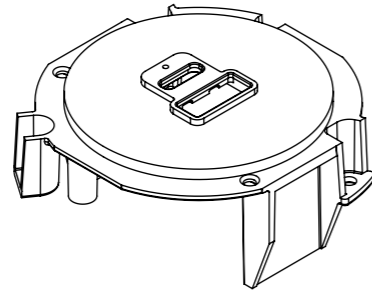

30W USB AC MODUAL = U

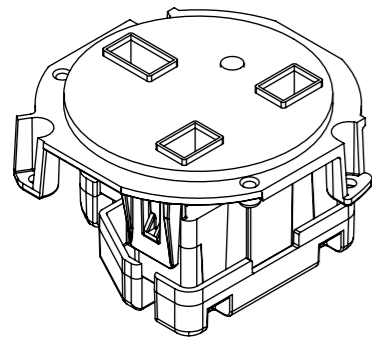

UK E FUSE OUTLET = B

**FACTORY ONLY INSERTABLE MODULES
REFER PAGE 2 FOR MODULE
CONFIGURATION**

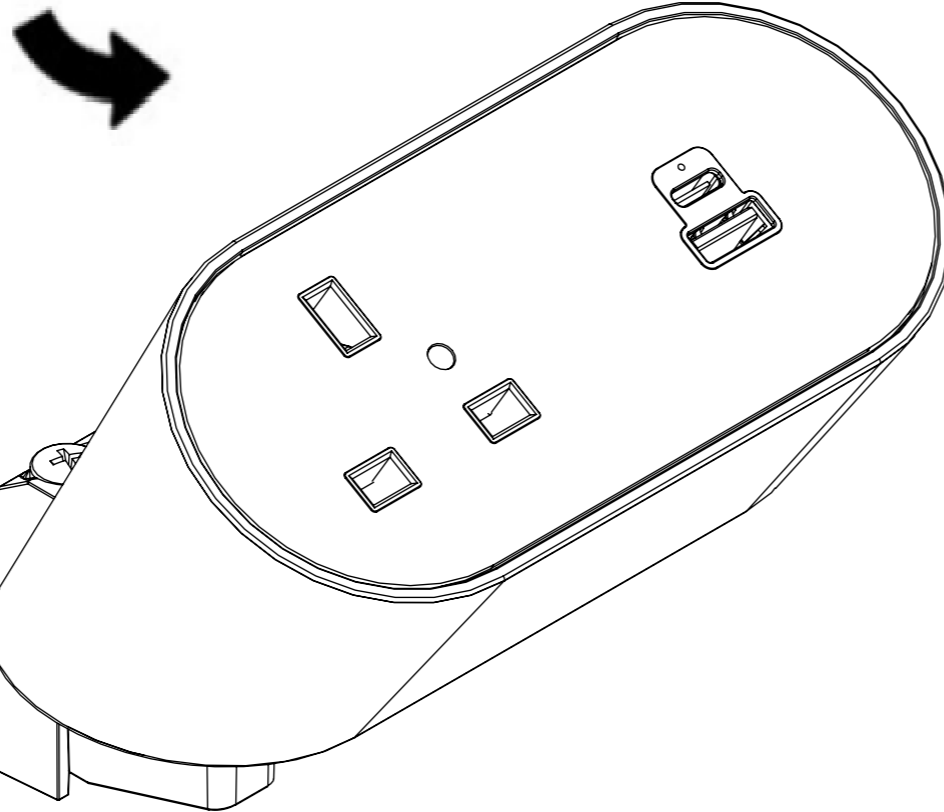

ABOVE DESK CLAMP

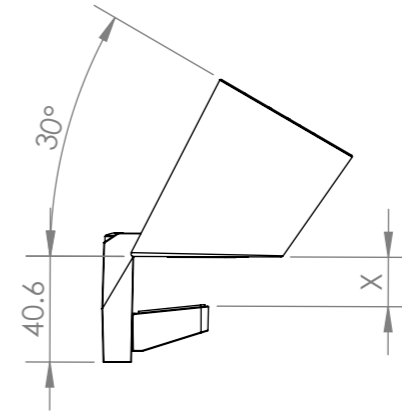

MIN TABLE THICKNESS: 20MM
MAX TABLE THICKNESS 32MM

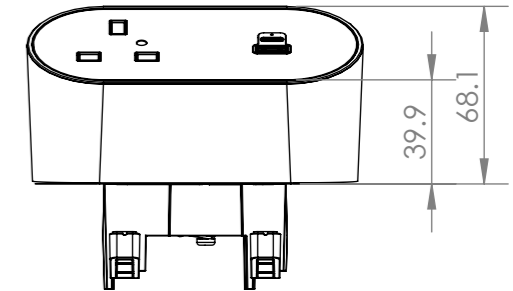
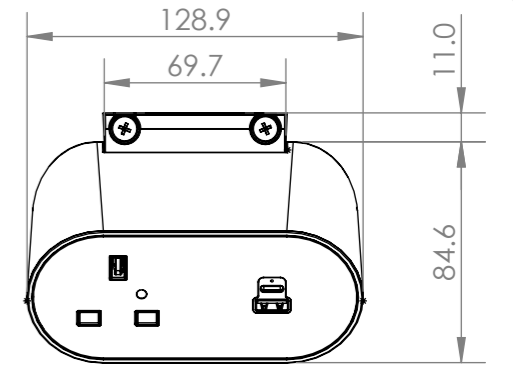

UNDER DESK CLAMP

COMPATIBLE MOUNTING
SCREWS: 4G, 6G

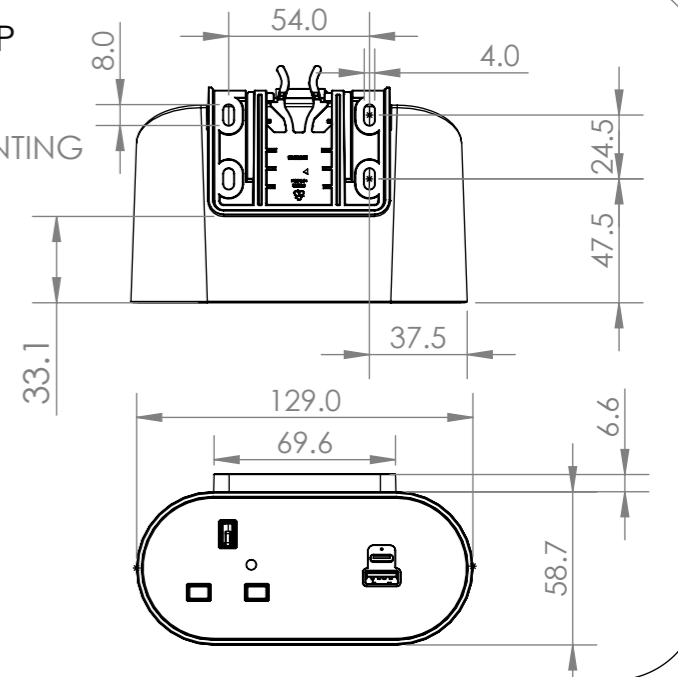
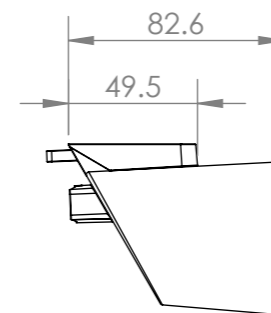

REV	DESCRIPTION	DATE	DRWN	APPV
3	COLOUR TABLE UPDATED	31/10/2023	JB	RG
2	SCREW NOTE ADDED FOR USE OF TYPE 25 OR TYPE B	28/7/2022	JB	RG
1	RELEASED FOR PRODUCTION	3/5/2022	JB	RG
REVISIONS				

CUSTOMER SIGNATURE:	
MATERIAL:	PC FR
FINISH:	FINE EDM / POLISHED / FABRIC
COLOUR:	REFER TABLE
THIS DRAWING & ASSOCIATED CAD FILES ARE ISSUED IN THE STRICTEST CONFIDENCE AND ARE ONLY TO BE USED IN THE COMMERCIAL INTERESTS OF CMS ELECTRACOM PTY LTD	

TOLERANCES UNLESS OTHERWISE STATED:

X ±0.5
X.X ±0.2
X.XX ±0.1
X.XXX ±0.05
ANG ±0.5°

DRAWN IN mm TO AS1100 DO NOT SCALE



TITLE:
NOVA DUO XL UK CONFIGURATIONS

DRAWING: LU39610
REV: 3
A3

SCALE 1:2

SHEET 1 OF 4

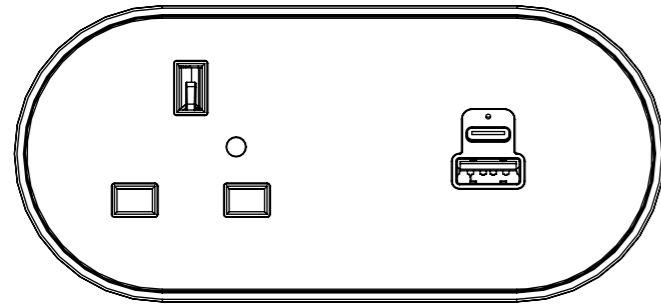

ND*BUXxxXX

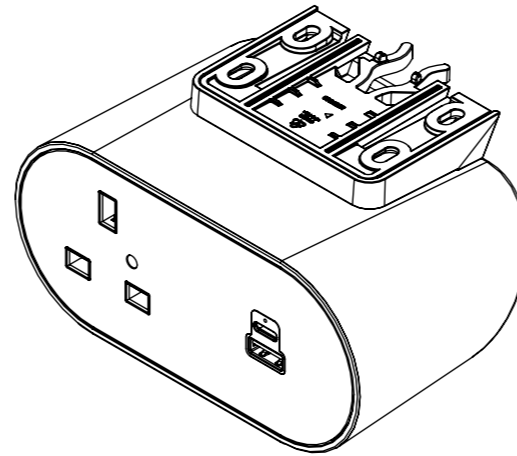

Z = UNDER DESK CLAMP

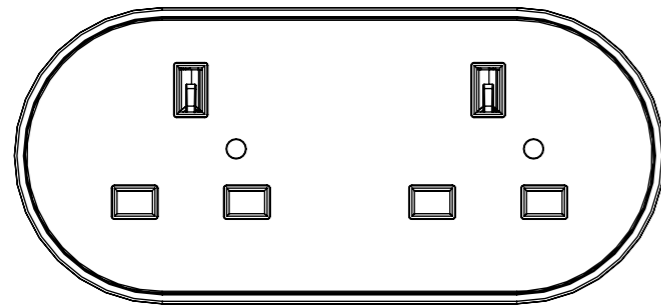

ND*BBXxxXX

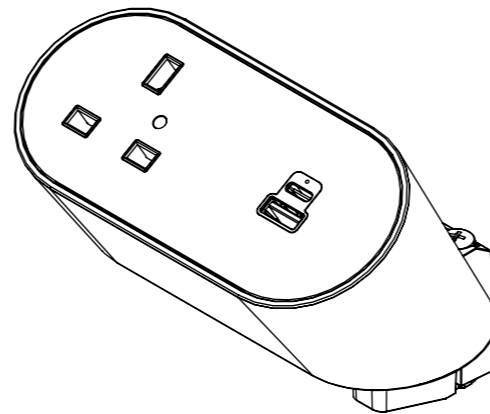

S= ABOVE DESK CLAMP

COLOUR VARIATIONS	
PART NUMBER	DESCRIPTION
W	WHITE BODY & CLAMP
B	BLACK BODY & CLAMP
1	WHITE DECAL GLOSS
2	WHITE DECAL MATT
3	BLACK DECAL GLOSS
4	BLACK DECAL MATT
FABRIC FINISH REFER TO LU41144	
A	FABRIC COLOUR 1 - VANILA
B	FABRIC COLOUR 2 - SMOKE
C	FABRIC COLOUR 3 - IRON FORMERLY KNOWN AS CHARCOAL
D	FABRIC COLOUR 4 - CHARCOAL FORMERLY KNOWN AS BLACK

NOTE:

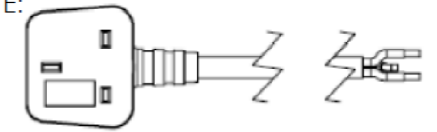

CABLE TYPE: 3 CORE x 1.5mm²
DESCRIPTION: BRITISH 13A PLUG LEAD
COLOUR: WHITE OR BLACK
(REFER TO PURCHASE ORDER)

xx	LENGTH (mm)
05	500
10	1000
15	1500
20	2000
25	2500
30	3000
35	3500
40	4000
45	4500
50	5000

NOTE:



CABLE TYPE: 3 CORE x 1.5mm²
DESCRIPTION: GST PLUG LEAD
COLOUR: WHITE OR BLACK
(REFER TO PURCHASE ORDER)

xx	LENGTH (mm)
05	500
10	1000
15	1500
20	2000
25	2500
30	3000
35	3500
40	4000
45	4500
50	5000

PART NUMBER: (REFER CONFIGURATION)xxXX

NOTE - * - CLAMP TYPE - (S = ABOVE DESK OR Z = UNDER DESK)

X - LEAD TYPE (BS PLUG = B), (GST CONNECTOR = W)

xx - LENGTH - 05 / 10 / 15 / 20 / 25 / 30 / 35 / 40 / 45 / 50

XX - COLOUR - W / B + 1 / 2 / 3 / 4 + (OPTIONAL) A / B / C / D

CUSTOMER SIGNATURE:	TOLERANCES UNLESS OTHERWISE STATED:	 CMS Electracom COPYRIGHT © 2020	
MATERIAL: PC FR	X ±0.5 X.X ±0.2 X.XX ±0.1 X.XXX ±0.05 ANG ±0.5°		
FINISH: FINE EDM / POLISHED / FABRIC		TITLE: NOVA DUO XL UK CONFIGURATIONS	
COLOUR: REFER TABLE		DRAWING: LU39610	REV: 3
THIS DRAWING & ASSOCIATED CAD FILES ARE ISSUED IN THE STRICTEST CONFIDENCE AND ARE ONLY TO BE USED IN THE COMMERCIAL INTERESTS OF CMS ELECTRACOM PTY LTD		SCALE 1:2	SHEET 2 OF 4
DRAWN IN mm TO AS1100 DO NOT SCALE		A3	