

USE SC\_CMS131\_11  
WHEN INSTALLING USB

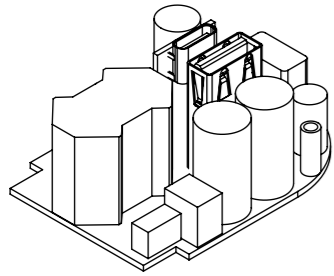

30W USB AC MODUAL = U

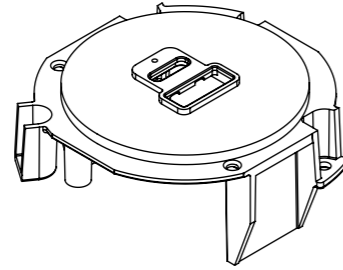

**FACTORY ONLY INSERTABLE MODULES  
REFER PAGE 2 FOR MODULE  
CONFIGURATION**

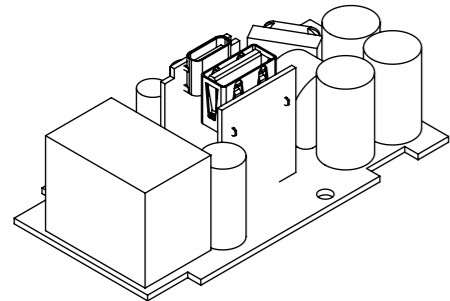

65W USB AC MODUAL = W

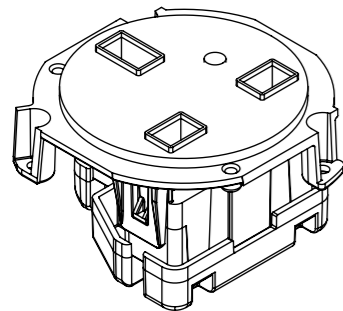

UK E FUSE OUTLET = B

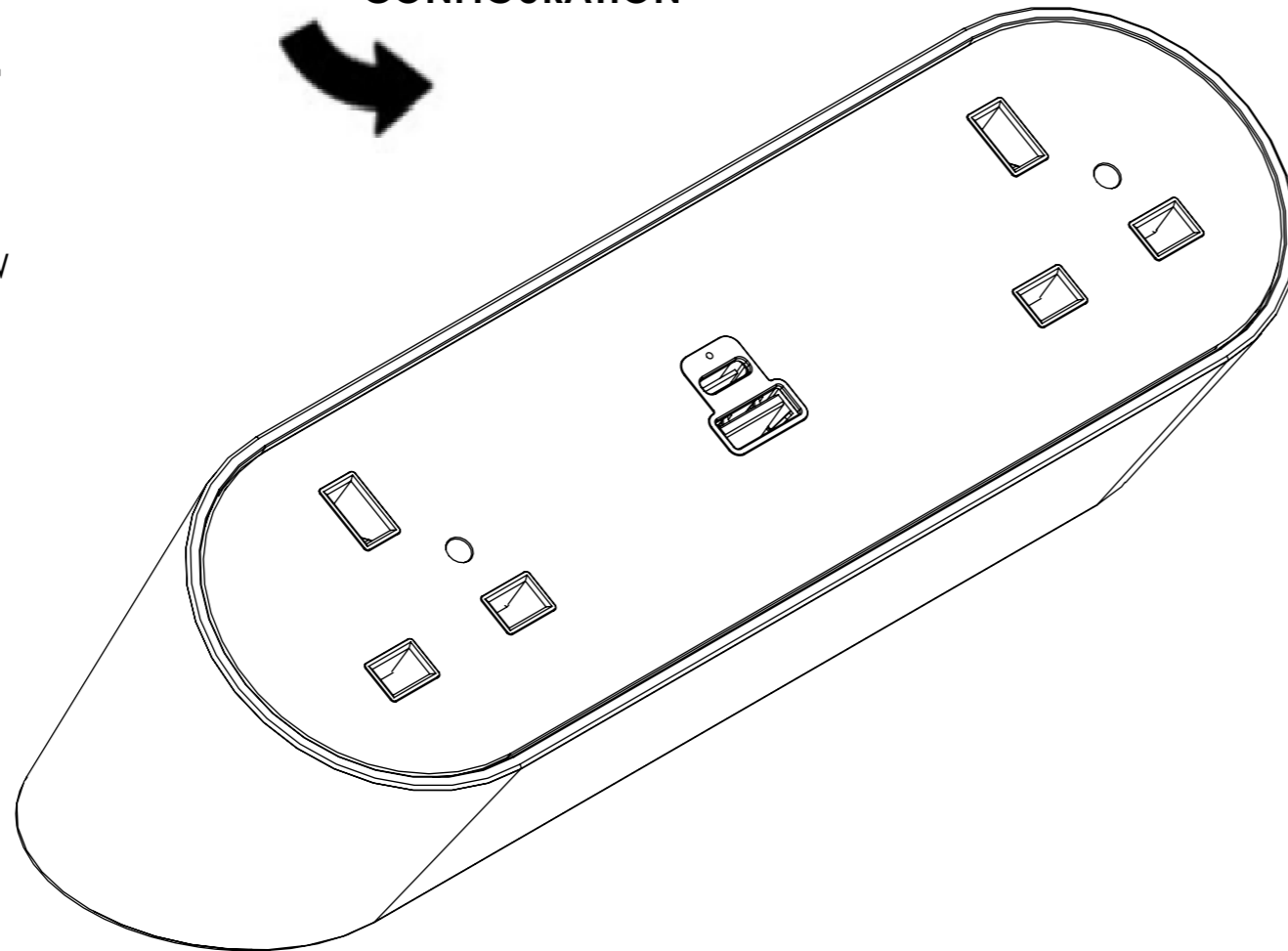

ABOVE DESK CLAMP

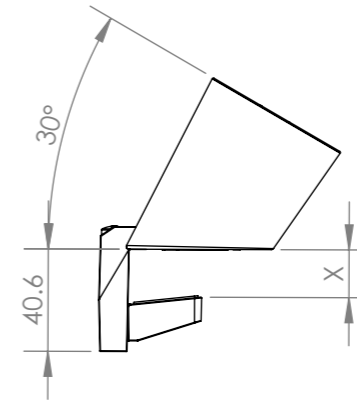
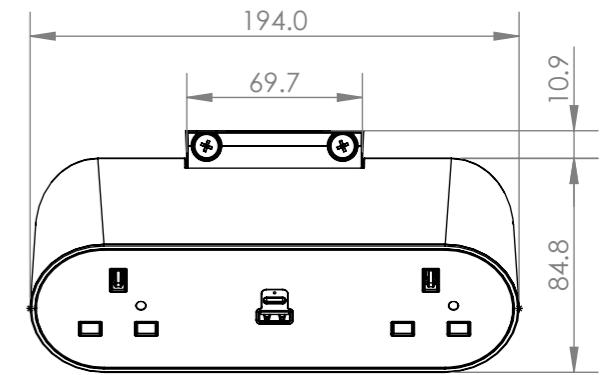

MIN TABLE THICKNESS: 20MM  
MAX TABLE THICKNESS 32MM

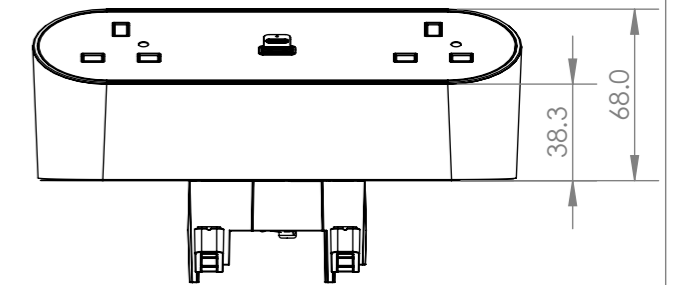

UNDER DESK CLAMP

COMPATIBLE MOUNTING  
SCREWS: 4G, 6G

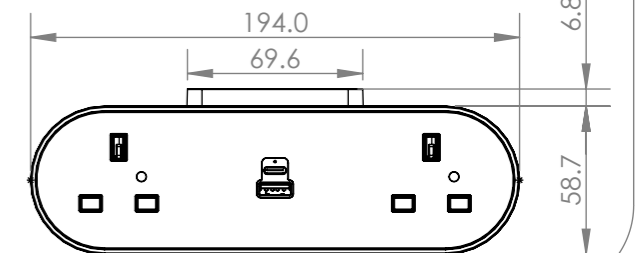
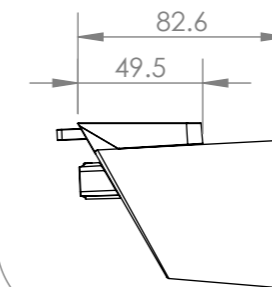
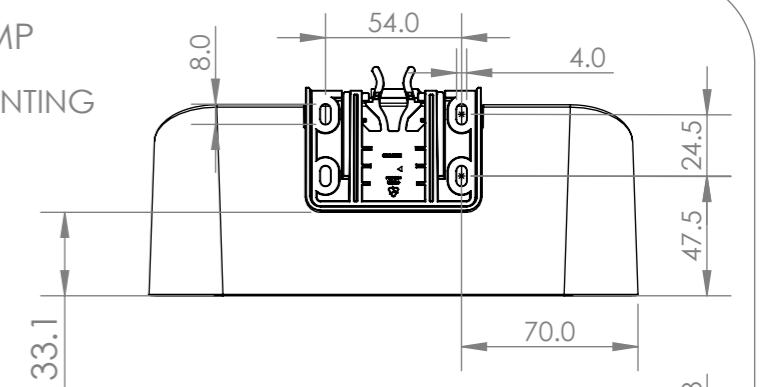

REV	DESCRIPTION	DATE	DRWN	APPV
4	COLOUR TABLE UPDTAED	31/10/2023	JB	RG
3	ITEM 2 IN BOM FIXED (WRONG PART LISTED)	19/1/2023	JB	RG
2	SCREW NOTE ADDED FOR USE OF TYPE 25 OR TYPE B	28/7/2022	JB	RG
1	RELEASED FOR PRODUCTION	3/5/2022	JB	RG
REVISIONS				

<b>CUSTOMER SIGNATURE:</b>
<b>MATERIAL:</b> PC FR
<b>FINISH:</b> FINE EDM / POLISHED / FABRIC
<b>COLOUR:</b> REFER TABLE
THIS DRAWING & ASSOCIATED CAD FILES ARE ISSUED IN THE STRICTEST CONFIDENCE AND ARE ONLY TO BE USED IN THE COMMERCIAL INTERESTS OF CMS ELECTRACOM PTY LTD

TOLERANCES UNLESS OTHERWISE STATED:

X ±0.5  
X.X ±0.2  
X.XX ±0.1  
X.XXX ±0.05  
ANG ±0.5°

DRAWN IN mm TO AS1100 DO NOT SCALE



**TITLE:**  
NOVA TRIO XL UK CONFIGURATIONS

<b>DRAWING:</b> LU39629	<b>REV:</b> 4	<b>A3</b>
SCALE 1:2	SHEET 1 OF 4	

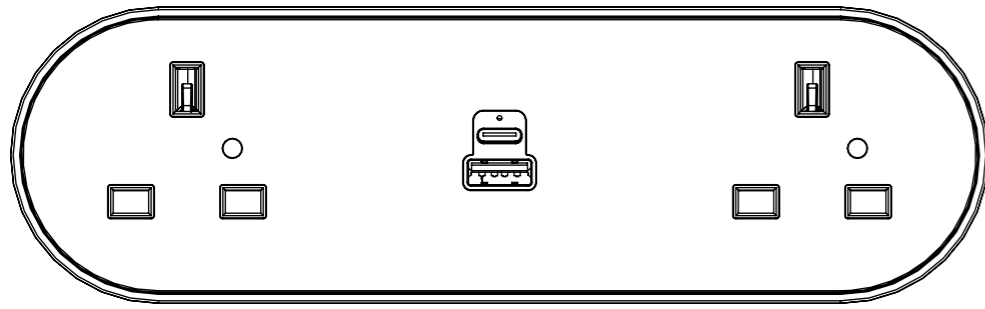

NT\*BUBXxxXX

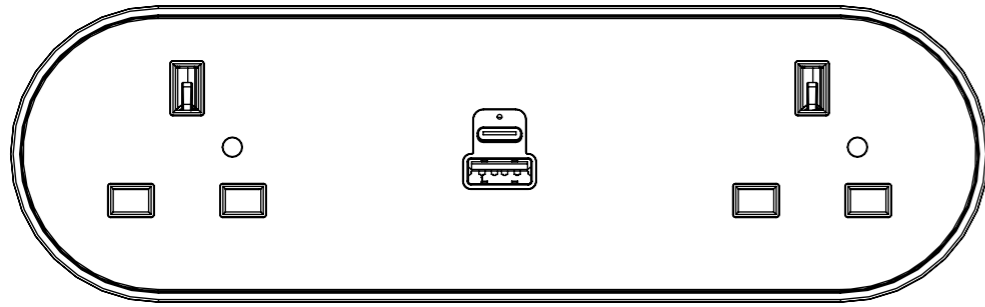

NT\*BWBXxxXX

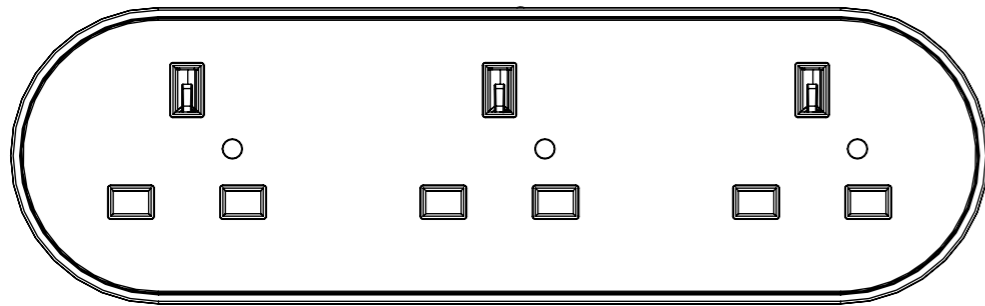

NT\*BBBXxxXX

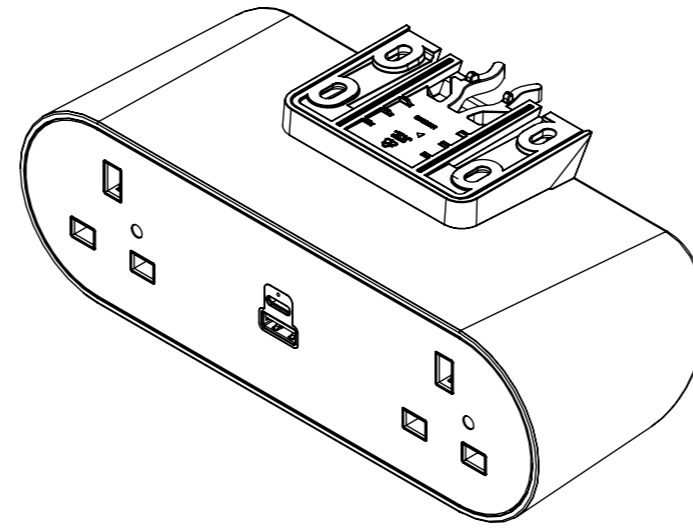

Z = UNDER DESK CLAMP

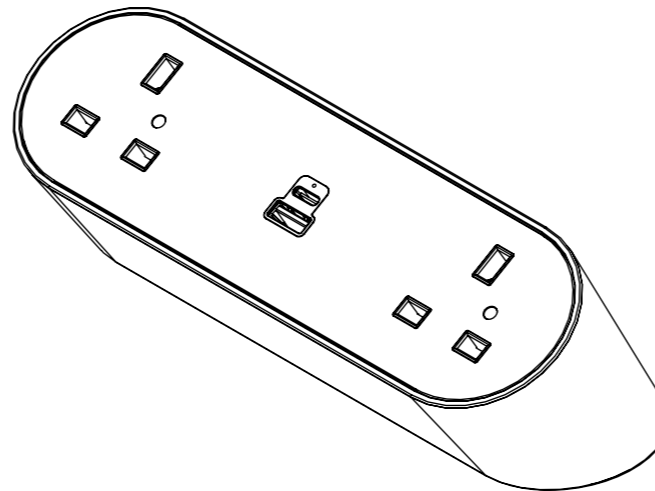

S= ABOVE DESK CLAMP

NOTE:

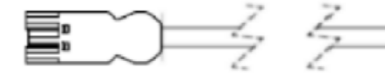

CABLE TYPE: 3 CORE x 1.5mm<sup>2</sup>  
 DESCRIPTION: GST PLUG LEAD  
 COLOUR: WHITE OR BLACK  
 (REFER TO PURCHASE ORDER)  
 LENGTH (mm):

xx	LENGTH (mm)
05	500
10	1000
15	1500
20	2000
25	2500
30	3000
35	3500
40	4000
45	4500
50	5000

NOTE:

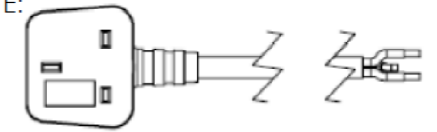

CABLE TYPE: 3 CORE x 1.5mm<sup>2</sup>  
 DESCRIPTION: BRITISH 13A PLUG LEAD  
 COLOUR: WHITE OR BLACK  
 (REFER TO PURCHASE ORDER)  
 LENGTH (mm):

xx	LENGTH (mm)
05	500
10	1000
15	1500
20	2000
25	2500
30	3000
35	3500
40	4000
45	4500
50	5000

COLOUR VARIATIONS	
PART NUMBER	DESCRIPTION
W	WHITE BODY & CLAMP
B	BLACK BODY & CLAMP
1	WHITE DECAL GLOSS
2	WHITE DECAL MATT
3	BLACK DECAL GLOSS
4	BLACK DECAL MATT
FABRIC FINISH REFER TO LU41142	
A	FABRIC COLOUR 1 - VANILA
B	FABRIC COLOUR 2 - SMOKE
C	FABRIC COLOUR 3 - IRON FORMERLY KNOWN AS CHARCOAL
D	FABRIC COLOUR 4 - CHARCOAL FORMERLY KNOWN AS BLACK

**PART NUMBER:** (REFER CONFIGURATION)xxXX  
 NOTE - \* - CLAMP TYPE - (S = ABOVE DESK OR Z = UNDER DESK)  
 X - LEAD TYPE (BS PLUG = B), (GST CONNECTOR = W)  
 xx - LENGTH - 05 / 10 / 15 / 20 / 25 / 30 / 35 / 40 / 45 / 50  
 XX - COLOUR - W / B + 1 / 2 / 3 / 4 + (OPTIONAL) A / B / C / D

<b>CUSTOMER SIGNATURE:</b>	<b>TOLERANCES UNLESS OTHERWISE STATED:</b>  X ±0.5 X.X ±0.2 X.XX ±0.1 X.XXX ±0.05 ANG ±0.5°	 <b>CMS Electracom</b> COPYRIGHT © 2020	
<b>MATERIAL:</b> PC FR			<b>TITLE:</b> NOVA TRIO XL UK CONFIGURATIONS
<b>FINISH:</b> FINE EDM / POLISHED / FABRIC		<b>DRAWING:</b> LU39629	<b>REV:</b> 4
<b>COLOUR:</b> REFER TABLE		SCALE 1:2	A3
THIS DRAWING & ASSOCIATED CAD FILES ARE ISSUED IN THE STRICTEST CONFIDENCE AND ARE ONLY TO BE USED IN THE COMMERCIAL INTERESTS OF CMS ELECTRACOM PTY LTD		SHEET 2 OF 4	