

USE SC_CMS131_11
WHEN INSTALLING USB

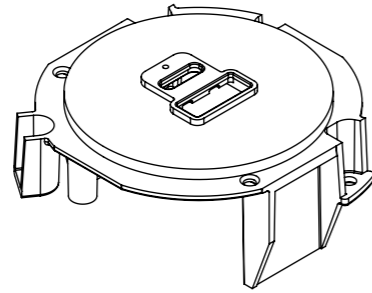

30W USB AC MODUAL = U

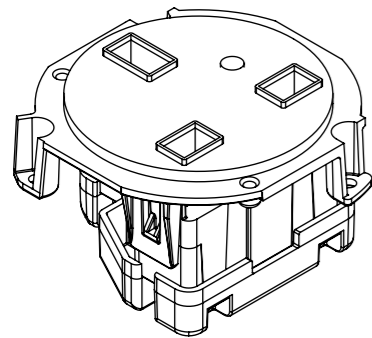

UK FUSED OUTLET = B

**FACTORY ONLY INSERTABLE MODULES
REFER PAGE 2 FOR MODULE
CONFIGURATION**

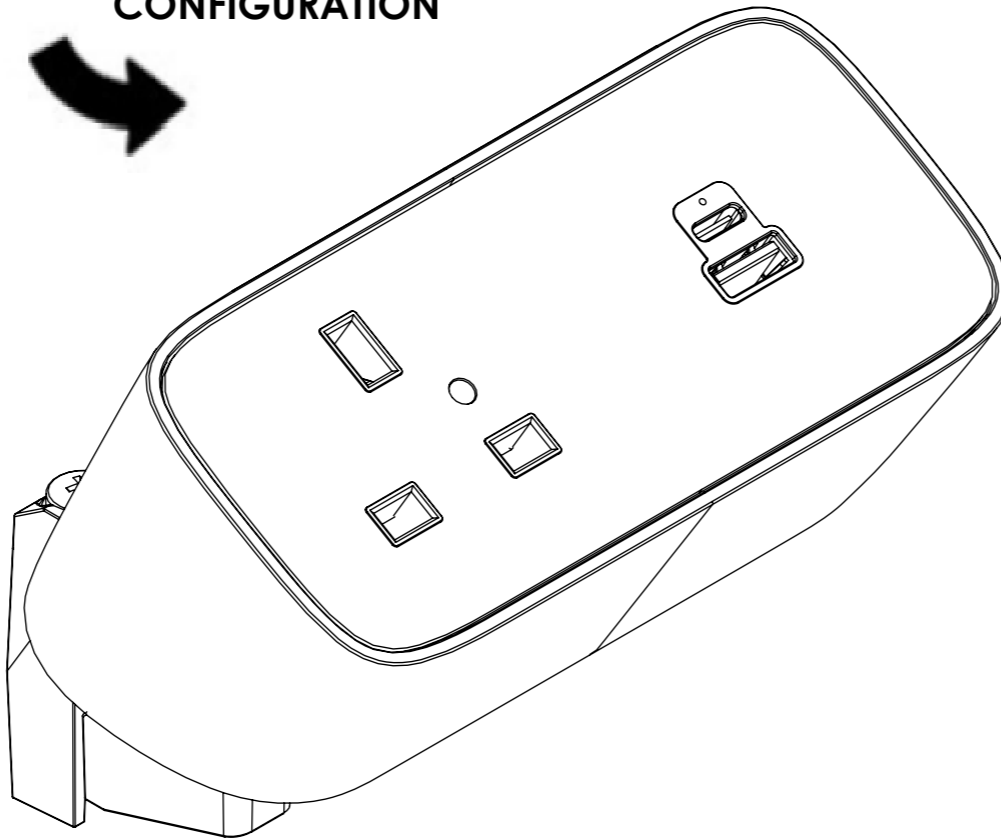

ABOVE DESK CLAMP

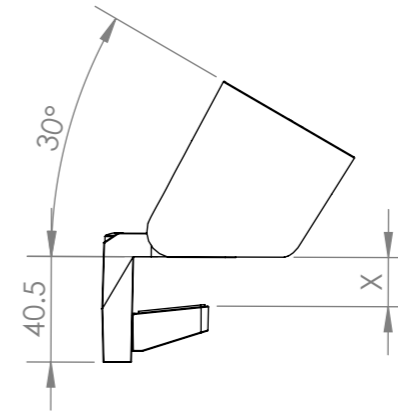

MIN TABLE THICKNESS: 20MM
MAX TABLE THICKNESS 32MM

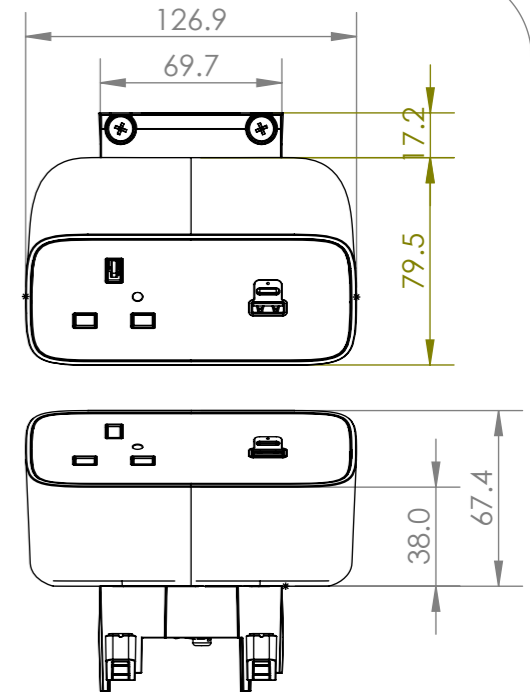

UNDER DESK CLAMP

COMPATIBLE MOUNTING
SCREWS: 4G, 6G

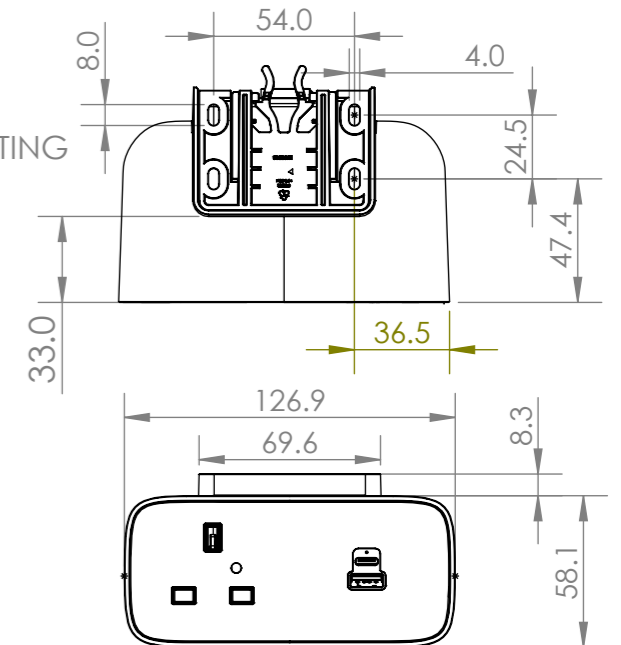
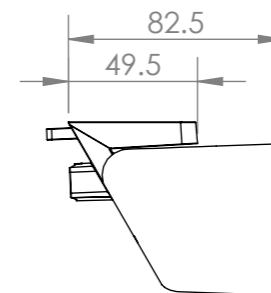

REV	DESCRIPTION	DATE	DRWN	APPV
2	SCREW NOTE ADDED FOR USE OF TYPE 25 OR TYPE B	29/7/2022	JB	RG
1	RELEASED FOR PRODUCTION	3/5/2022	JB	RG
REVISIONS				

CUSTOMER SIGNATURE:	
MATERIAL:	PC FR
FINISH:	FINE EDM / POLISHED / FABRIC
COLOUR:	REFER TABLE
THIS DRAWING & ASSOCIATED CAD FILES ARE ISSUED IN THE STRICTEST CONFIDENCE AND ARE ONLY TO BE USED IN THE COMMERCIAL INTERESTS OF CMS ELECTRACOM PTY LTD	

TOLERANCES UNLESS OTHERWISE STATED:

X ±0.5
X.X ±0.2
X.XX ±0.1
X.XXX ±0.05
ANG ±0.5°

DRAWN IN mm TO AS1100 DO NOT SCALE



TITLE:
VIVA DUO XL UK CONFIGURATIONS

DRAWING: LU39631	REV: 2	A3
SCALE 1:2	SHEET 1 OF 4	

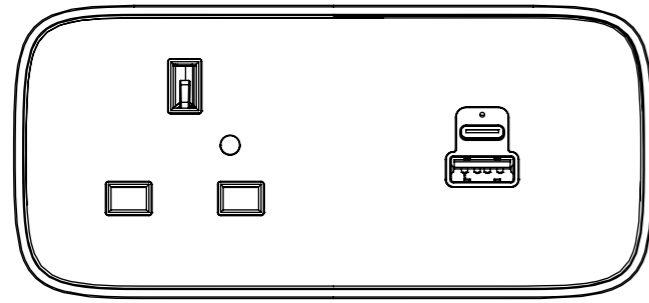

VD*BUXxxXX

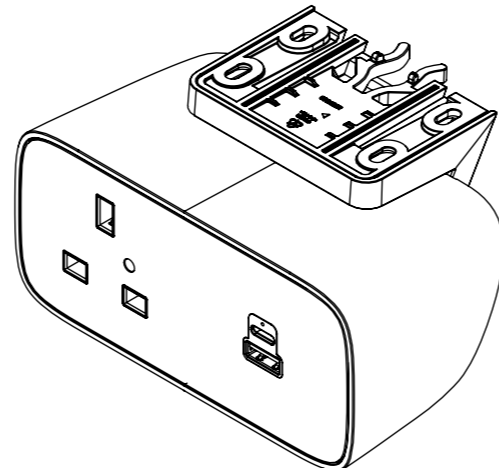

Z = UNDER DESK CLAMP

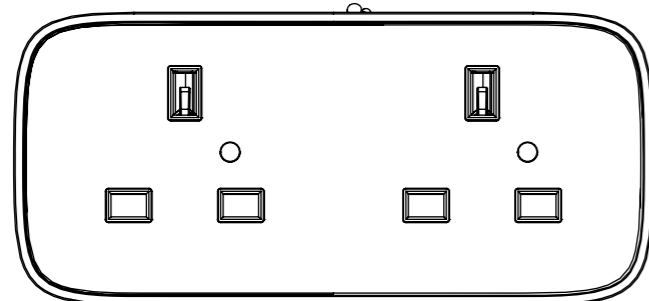

VD*BBXxxXX

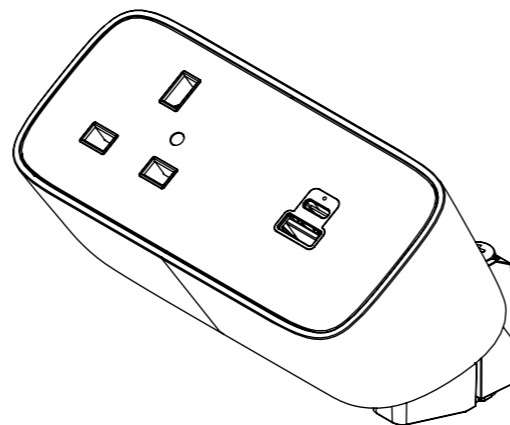

S= ABOVE DESK CLAMP

COLOUR VARIATIONS	
PART NUMBER	DESCRIPTION
W	WHITE BODY & CLAMP
B	BLACK BODY & CLAMP
1	WHITE DECAL GLOSS
2	WHITE DECAL MATT
3	BLACK DECAL GLOSS
4	BLACK DECAL MATT
FABRIC FINISH REFER TO LU38547	
A	FABRIC COLOUR 1
B	FABRIC COLOUR 2
C	FABRIC COLOUR 3
D	FABRIC COLOUR 4

NOTE:

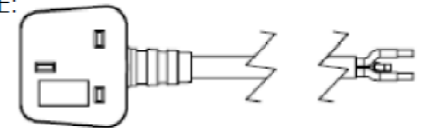

CABLE TYPE: 3 CORE x 1.5mm²
 DESCRIPTION: BRITISH 13A PLUG LEAD
 COLOUR: WHITE OR BLACK
 (REFER TO PURCHASE ORDER)

xx	LENGTH (mm)
05	500
10	1000
15	1500
20	2000
25	2500
30	3000
35	3500
40	4000
45	4500
50	5000

NOTE:



CABLE TYPE: 3 CORE x 1.5mm²
 DESCRIPTION: GST PLUG LEAD
 COLOUR: WHITE OR BLACK
 (REFER TO PURCHASE ORDER)

xx	LENGTH (mm)
05	500
10	1000
15	1500
20	2000
25	2500
30	3000
35	3500
40	4000
45	4500
50	5000

PART NUMBER: (REFER CONFIGURATION)xxXX

NOTE - * - CLAMP TYPE - (S = ABOVE DESK OR Z = UNDER DESK)

X - LEAD TYPE (BS PLUG = B), (GST CONNECTOR = W)

xx - LENGTH - 05 / 10 / 15 / 20 / 25 / 30 / 35 / 40 / 45 / 50

XX - COLOUR - W / B + 1 / 2 / 3 / 4 + (OPTIONAL) A / B / C / D

CUSTOMER SIGNATURE:	TOLERANCES UNLESS OTHERWISE STATED: X ±0.5 X.X ±0.2 X.XX ±0.1 X.XXX ±0.05 ANG ±0.5°	 CMS Electracom COPYRIGHT © 2020		
MATERIAL: PC FR				TITLE: VIVA DUO XL UK CONFIGURATIONS
FINISH: FINE EDM / POLISHED / FABRIC		DRAWING: LU39631	REV: 2	A3
COLOUR: REFER TABLE		SCALE 1:2		
THIS DRAWING & ASSOCIATED CAD FILES ARE ISSUED IN THE STRICTEST CONFIDENCE AND ARE ONLY TO BE USED IN THE COMMERCIAL INTERESTS OF CMS ELECTRACOM PTY LTD		DRAWN IN mm TO AS1100 DO NOT SCALE		