



2015-16 Ducting & Trunking Application Guide

**Wiring + Power
Solutions**

cmselectra.com

Table of Contents

Page 3 Key Contacts List

Skirting Duct

Page 6 Skirting Duct - SK35 Series-150mm x 35mm - 2 Channel

Page 9 Skirting Duct - SK50 Series -150mm x 50mm - 2 Channel

Floor Trunking

Page 12 Trunking - Flush Floor

Page 13 Trunking - Screed Floor

Electrical Poles

Page 16 Power Pole - SPA28 2800mm

Page 17 Power Pole - SPA33 3300mm

Page 18 Totem Power Pole - SPT06AN 670mm

Page 19 Totem Power Pole - SPT21AN 2100mm

Page 20 Totem Power Pole - SPT28AN 2800mm

Page 21 Totem Power Pole - SPT33AN 3300mm

Page 22 Centrepoint Series II - CPT2-02U - 300mm

Page 23 Centrepoint Series II - CPT2FD - 720mm

Page 24 Centrepoint Series II - CPT2FS - 900mm

Page 25 Centrepoint Series II - CPT2CW - 2100mm

Page 26 Centrepoint Series II - CPT2CF - 2800mm

Key Contacts

KEY CONTACTS

Sales - All Regions

Customer Service

+61 2 8814 8133

sales@cmselectra.com

.....

Sydney Office

24 Binney Road

Kings Park NSW 2148

Sales: 1300 159 159

Telephone: 02 8814 8133

Facsimile: 02 8814 8399

.....

Melbourne Office

76-78 Leggo Court

Dandenong VIC 3175

Sales: 1300 159 159

Telephone: 03 9768 4833

Facsimile: 03 9706 5663

.....

Brisbane Office

Unit 4, 300 Cullen Avenue East

Eagle Farm QLD 4009

Sales: 1300 159 159

Telephone: 07 3209 7299

Facsimile: 07 3209 6806

.....

Perth Office

10/41 Holder way

Malaga WA 6090

Sales: 1300 159 159

Telephone: 08 9209 1166

Facsimile: 08 9248 1689

.....

NZ Office

Hamlins Hill Commercial Centre

Unit E27, 930 Great South Road

Penrose, Auckland 1061

Telephone: 09 582 0776

Facsimile: 09 525 0846

.....

London Office

31-35 Kirby Street

London EC1N 8TE

T +44 (0) 203 356 9709

F +44 (0) 203 356 9709

uksales@cmselectra.com

.....

Singapore Office

203 Henderson Road

#01-04 Henderson Industrial Park

SINGAPORE 159546

T +65 945 704 61

E asiasales@cmselectra.com

.....

Malaysia

Chris Cramond

Sales Manager - Asia Pacific

T +65 945 704 61

E chris@cmselectra.com

.....

Website

www.cmselectra.com

About CMS

CMS Electracom is an Australasian global leader supplying innovative wiring solutions to commercial and industrial applications.

CMS Electracom commenced business in 1979 supplying custom made cable harnesses and wiring assemblies for the data and electrical industry.

Our head office and modern manufacturing facility is located in the Melbourne suburb of Dandenong. Combined with sales operations in Sydney, Brisbane, Perth, New Zealand, UK, and an Australasian wide distribution network.

We have, over recent years been expanding our range of electrical products used in the commercial building sector and are committed to continued expansion in this area. CMS offers you a wealth of expertise in softwiring and power solutions for commercial buildings, and the flexibility of customisation to assist in fulfilling any special requirements you may have.



Modular Wiring



Floor Boxes & Floor



Busbar



Screed Trunking



Power Pole



Dali Lighting



Installation tools



Skirting Duct

CMS Ducting and Trunking Solutions

Since 1979, CMS Electracom, a leading manufacturer and innovator of Softwiring, Cable Management and Floor Boxes has worked with leading designers, engineers and builders to supply wiring and power solutions to all types of commercial and industrial applications.

CMS supplies wiring and power products to Australia, New Zealand, United Kingdom and Asia- Pacific customers. Our products are installed in office fitouts, shopping centres, banks, classrooms and government agencies worldwide.

The CMS range of Ducting and Trunking Products allows you to install power, audio, video, telecommunications, and data ports around your work space. CMS Electracom in-house design team provide custom solutions to all projects.

CMS Ducting and Trunking Products blend seamlessly into any environment to suit the aesthetics of the space and engineered to perform. Our team of dedicated professionals are trained to work with you in delivering the right wiring and power solution within time and budget.

CMS Electracom manufactures all their wiring and power products under strict quality standards in their state of the art manufacturing plant in Victoria, Australia.

With over 30 years industry experience, CMS Electracom are market leaders in supplying wiring and power solutions.

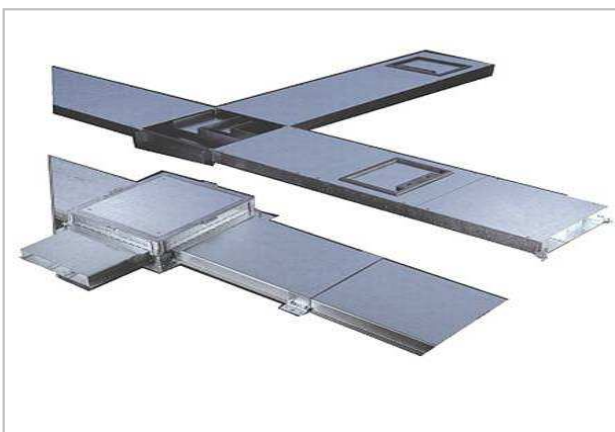

SK35 Series Skirting Duct Specification

TYPE: CMS 150mm x 35mm - 2 Channel

The contractor shall supply and install a CMS 150mm x 35mm, three compartment (2 Cable compartments, 1 outlet compartment), surface mounted or semi/fully recessed skirting duct system, as indicated on the tender drawing.

The duct system shall incorporate separate compartments for the power and data/telephone cabling. The skirting duct body is to measure 150mm x 35mm and be constructed of extruded Aluminium anodised or powder coated in a colour to be selected by the superintendent.

The duct lid is to be manufactured from 0.8mm thick thermally bonded vinyl veneer Versiclad or powder coated in a matching colour. The skirting duct body is to be supplied in 2.4mtr lengths with lid panels in 1.2mtr lengths.

CMS Electracom shall ensure straightness, consistency of cross sectional tolerances and adequate rigidity against twisting and distortion. Exposed duct ends are to be fixed with purpose made end plates.

The corners shall be accurately cut straight with the recommended cutting equipment, secured with angle brackets and purpose made internal and external corner cover pieces.

Service outlets are to be centrally mounted in the designated service channel in one-level configuration and positioned at the nominated locations. Individual outlet lid section shall be punched to suit the service outlets. The outlet lid sections will be supplied with a universal clip in box for cable separation of differing services and shall be readily capable of relocation for future requirements.

Skilled tradesmen utilising the recommended cutting equipment are to be employed for the duct installation.

SK35 Series Skirting Duct Specification

SK35 Series

TECHNICAL SPECIFICATIONS:

CMS SK35 Series 2 channel (2 wiring compartments and 1 central fit-off zone compartment) anodised or powder coated extruded aluminium skirting duct body, complete with PVC sheeted steel Versiclad drop in cover with all outlets mounted on the one level.

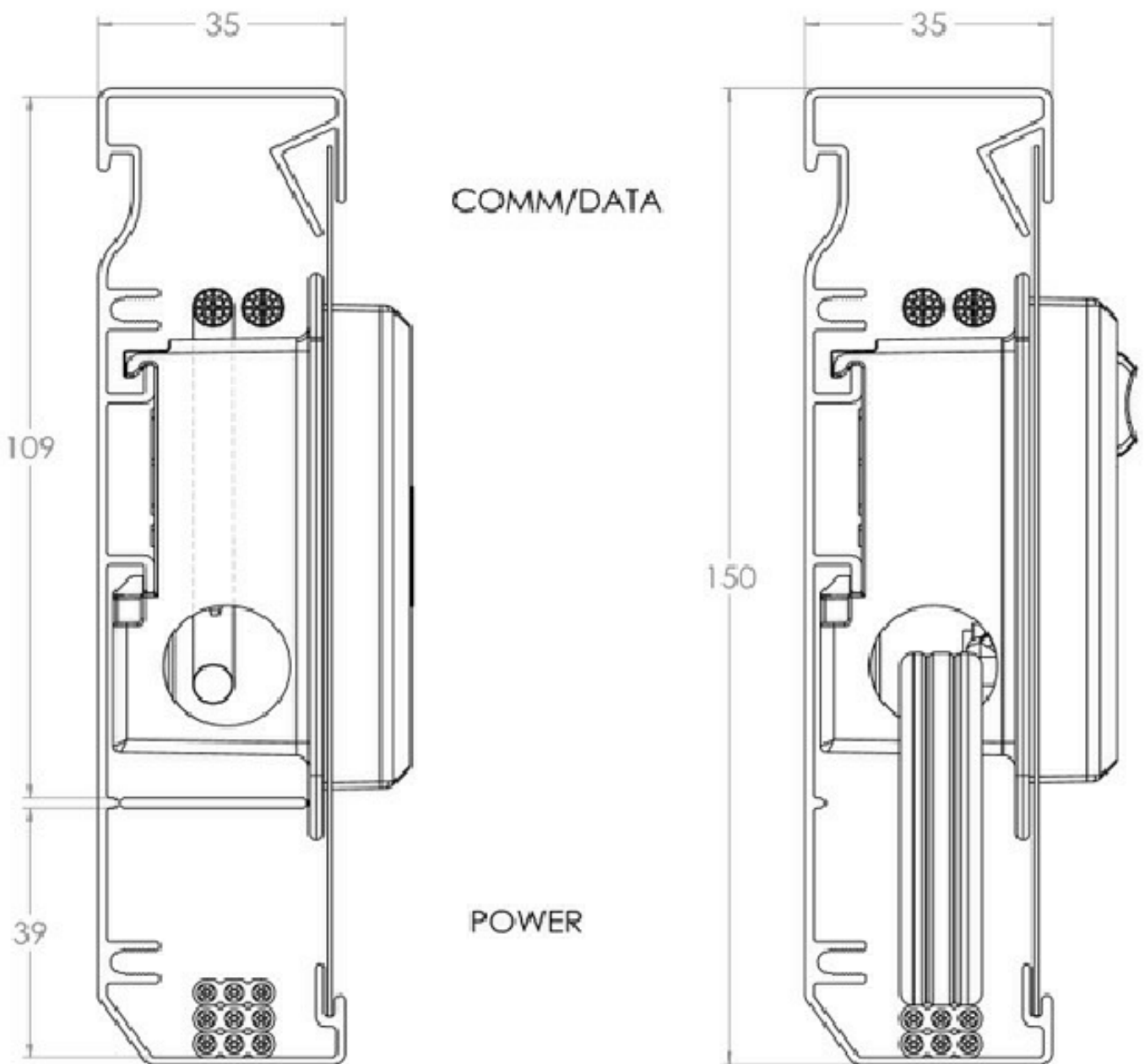

SK35 Series Skirting Duct Specification

PART NO: SK35D

CMS Skirting duct 150mm x 35mm - 2.4m

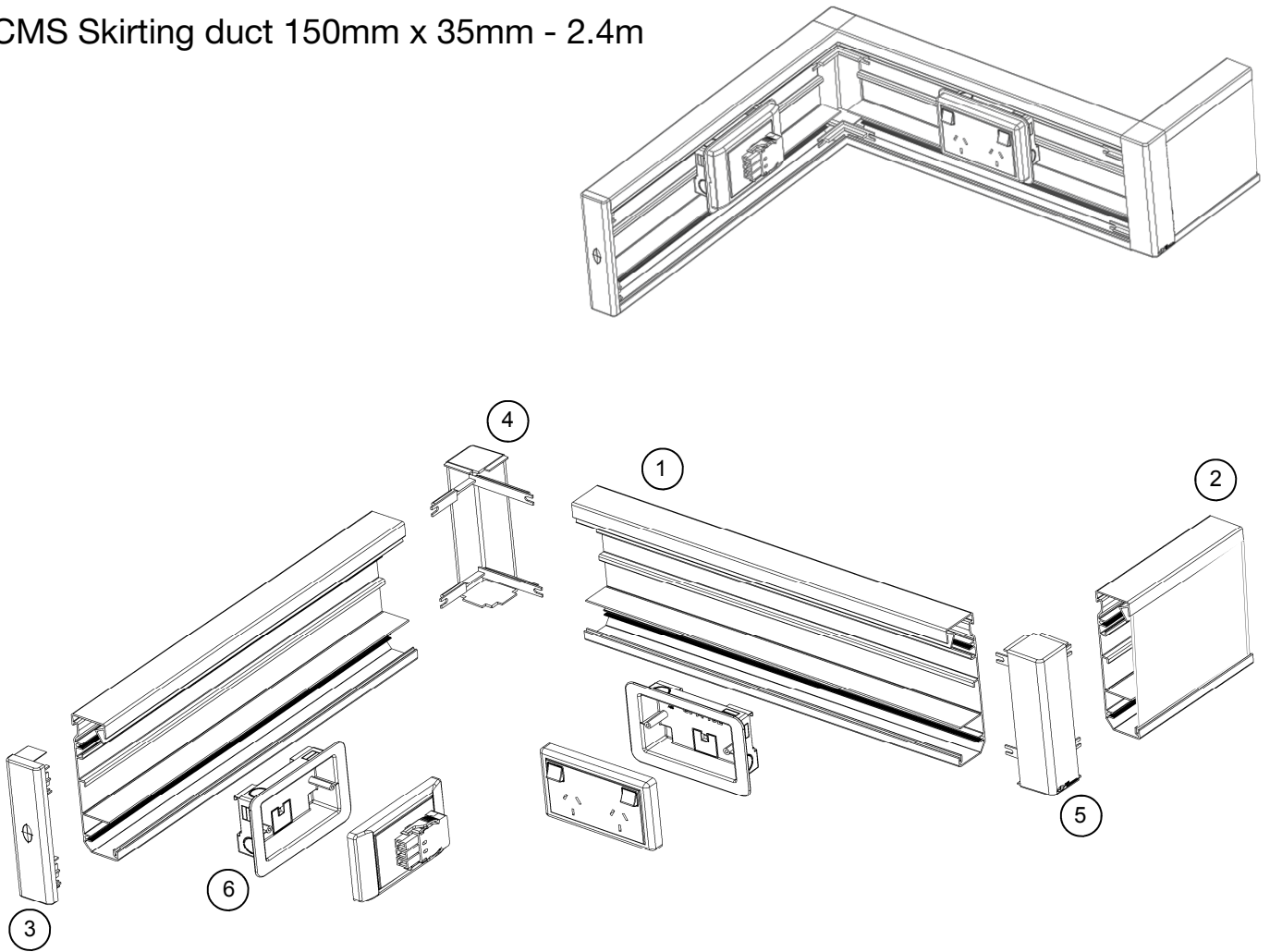

ITEM NO.	DESCRIPTION	QTY
1	PART NO: SK35D Skirting Duct 150mm x 35mm - 2.4mm lengths	1
2	PART NO: SKC Skirting cover 150mm high - 1.2m lengths (suits 35mm & 50mm deep)	1
3	PART NO: SK35E 35mm SK End cap	1
4	PART NO: SK35I 35mm SK Internal Cnr	1
5	PART NO: SK35X 35mm SK External Cnr	1
6	PART NO: SKGPO Universal accessory box to suit duct with outlet cover plate - 200mm	1

SK50 Series Skirting Duct Specification

TYPE: CMS 150mm x 50mm - 2 Channel

The contractor shall supply and install a CMS 150mm x 50mm, three compartment (2 Cable compartments, 1 outlet compartment), surface mounted or semi/fully recessed skirting duct system, as indicated on the tender drawing.

The duct system shall incorporate separate compartments for the power and data/telephone cabling. The skirting duct body is to measure 150mm x 50mm and be constructed of extruded Aluminium anodised or powder coated in a colour to be selected by the superintendent.

The duct lid is to be manufactured from 0.8mm thick thermally bonded vinyl veneer Versiclad or powder coated in a matching colour. The skirting duct body is to be supplied in 2.4mtr lengths with lid panels in 1.2mtr lengths.

CMS Electracom shall ensure straightness, consistency of cross sectional tolerances and adequate rigidity against twisting and distortion. Exposed duct ends are to be fixed with purpose made end plates. The corners shall be accurately cut straight with the recommended cutting equipment, secured with angle brackets and purpose made internal and external corner cover pieces.

Service outlets are to be centrally mounted in the designated service channel in one-level configuration and positioned at the nominated locations. Individual outlet lid section shall be punched to suit the service outlets. The outlet lid sections will be supplied with a steel universal clip in box for cable separation of differing services and shall be readily capable of relocation for future requirements.

Skilled tradesmen utilising the recommended cutting equipment are to be employed for the duct installation.

SK50 Series Skirting Duct Specification

SK50 Series

TECHNICAL SPECIFICATIONS:

CMS SK50 Series 2 channel (2 wiring compartments and 1 central fit-off zone compartment) anodised or powder coated extruded aluminium skirting duct body, complete with PVC sheeted steel Versiclad drop in cover with all outlets mounted on the one level.

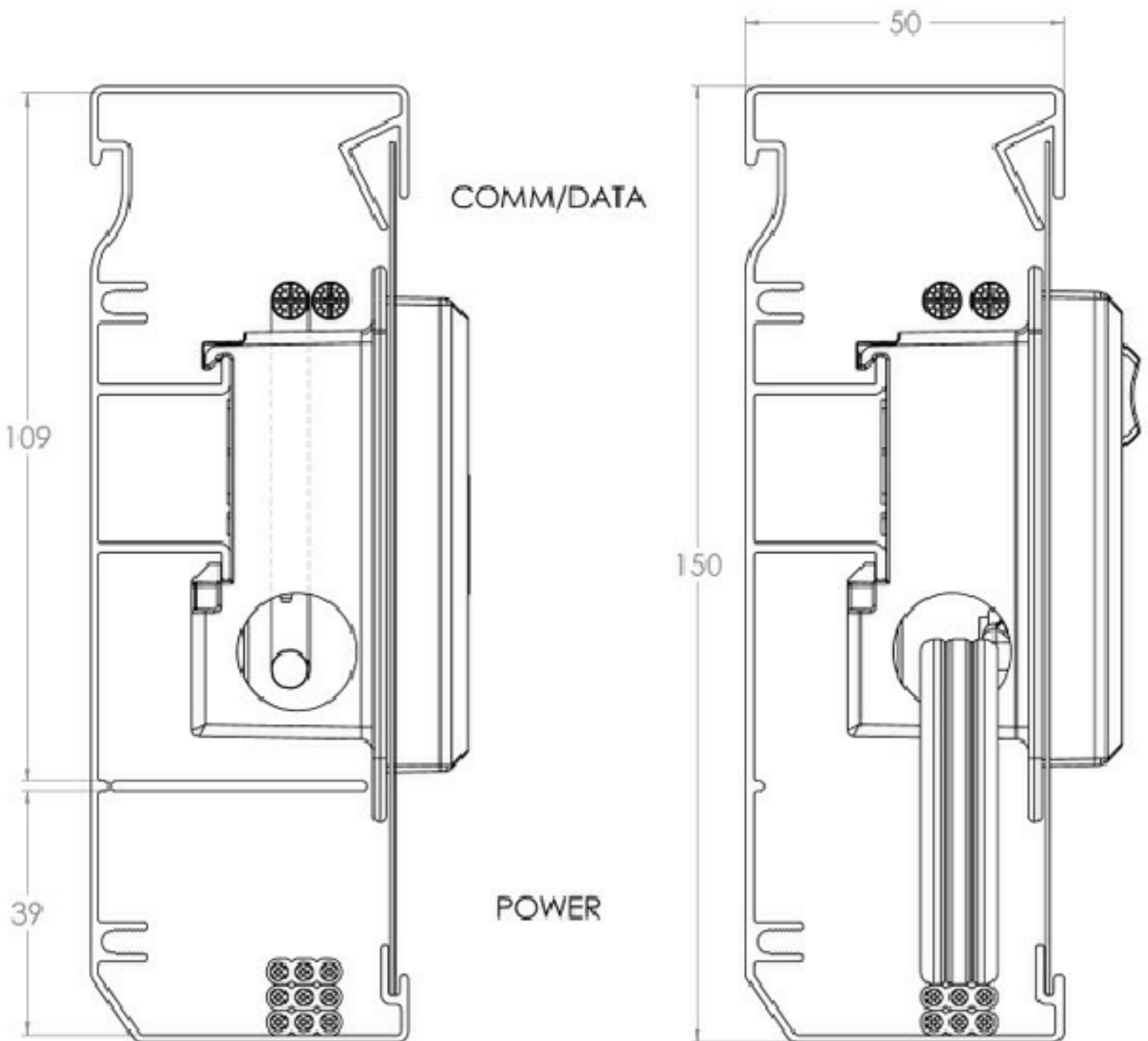

SK50 Series Skirting Duct Specification

PART NO: SK50D

CMS Skirting duct 150mm x 50mm - 2.4m

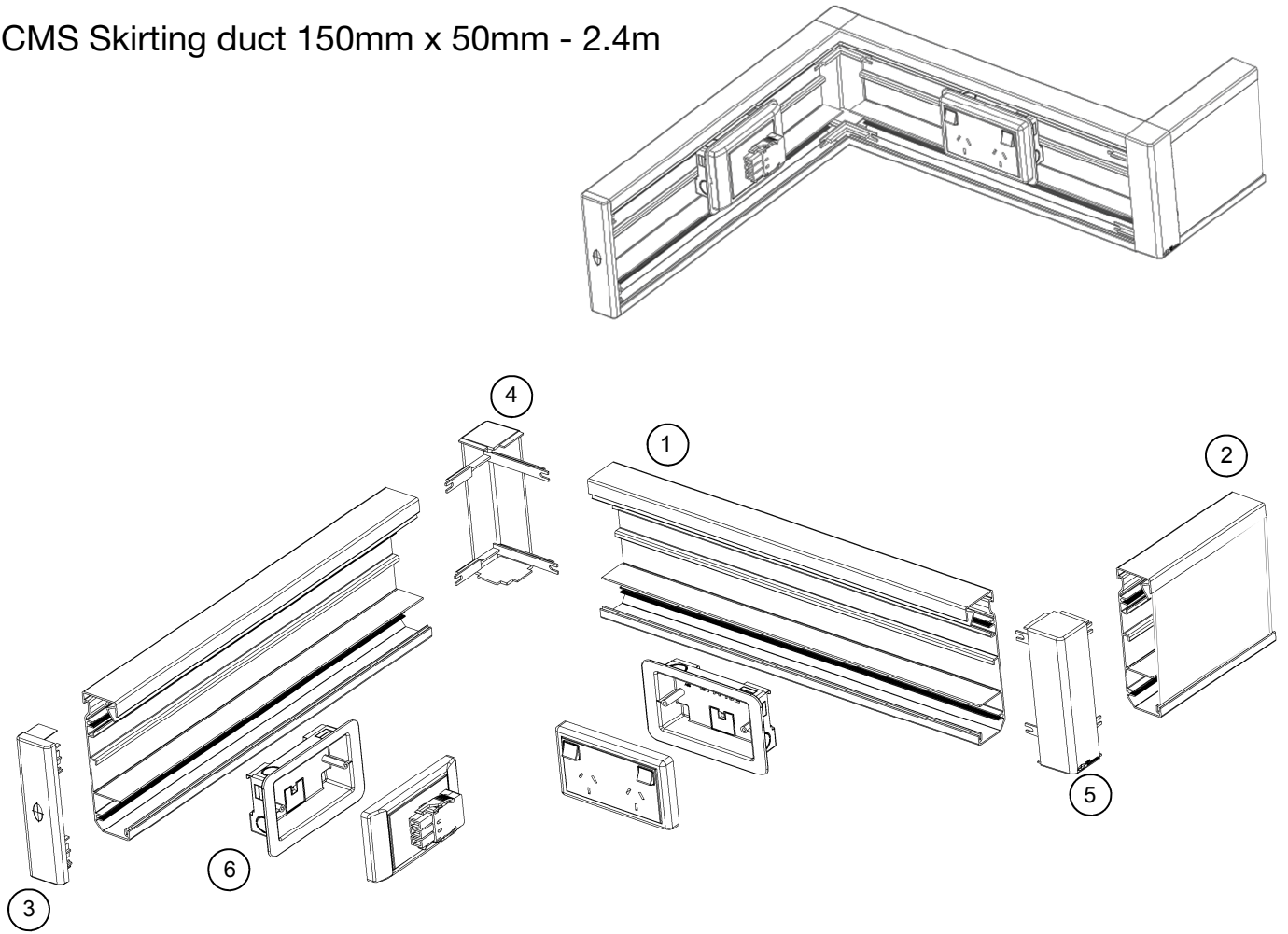

ITEM NO.	DESCRIPTION	QTY
1	PART NO: SK50D Skirting Duct 150mm x 50mm - 2.4mm lengths	1
2	PART NO: SKC Skirting cover 150mm high - 1.2m lengths (suits 35mm & 50mm deep)	1
3	PART NO: SK50E 50mm SK End cap	1
4	PART NO: SK50I 50mm SK Internal Cnr	1
5	PART NO: SK50X 50mm SK External Cnr	1
6	PART NO: SKGPO Universal accessory box to suit duct with outlet cover plate - 200mm	1

Flush Floor Trunking

Base Trunking

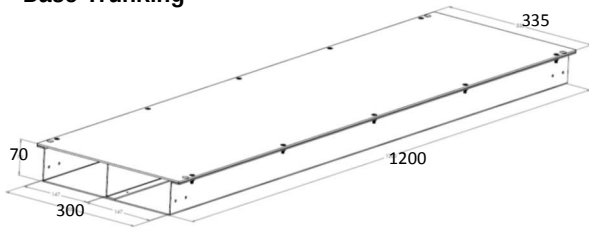

Junction Boxes

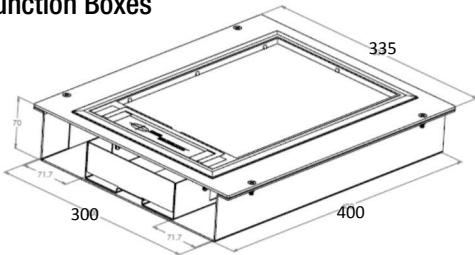

Levelling/joiner plate

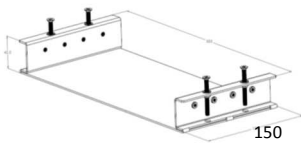

Cross fitting

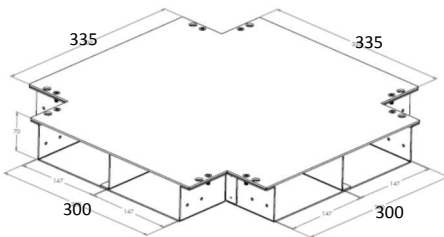

'T' fitting

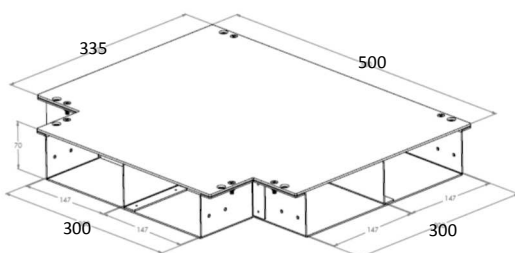

BASE TRUNKING	PART NO.
1200mm x 335 x 70	FF33570

PLATE ACCESSORIES	H	PART NO.
Cross	70	FF33570C
Leveling & Joiner		FF33570LP
Tee	70	FF33570T
90° Bend	70	FF33570B
Junction box	70	FF335705JB

THE TRUNKING MUST BE INSTALLED ON A FLAT SOLID SURFACE, PREFERABLY WITH A MINIMUM RIBBON SCREED THICKNESS OF 10MM AND SET FLUSH IN THE SCREED

* Special sizes available upon request

Bend fitting

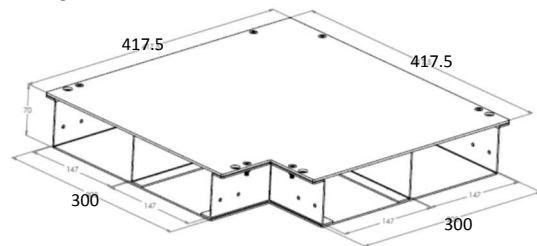

* Note: Junction box comes with 4 x GPO's, 1 x L3.20 Rewireable connector, 4 x Provision for data, 1 x Apollo series 4 compartment floor box lid.

Screed Trunking

Base Trunking

BASE TRUNKING

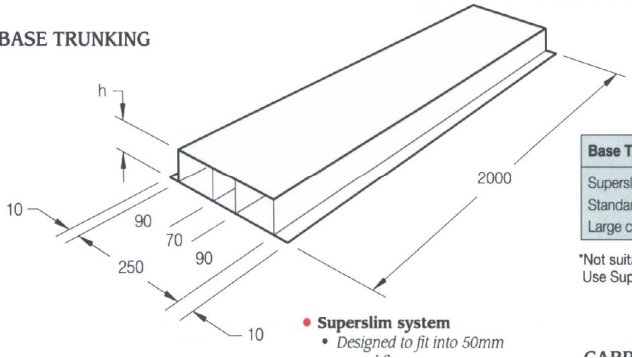

Junction boxes

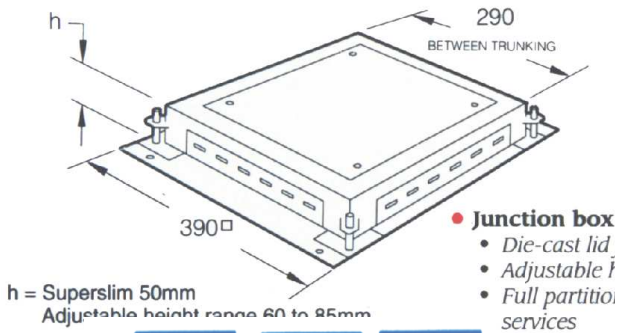

Carpet trim for Junction box

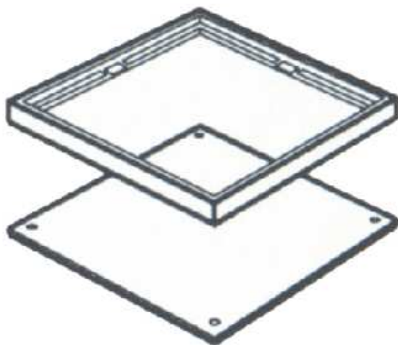

$h =$ Adjustable height range 60 to 85mm

Special Features:

- Simple to install
- Sturdy construction
- 2mm thick steel trunking
- 2 compartment floorbox
- Moulded carpet trim

BASE TRUNKING	H	PART NO.
Standard	28	ST20028
Large capacity	38	ST20038

JUNCTION BOX:

- Die cast lid for maximum strength
- Adjustable height for easy levelling

JUNCTION BOX	TYPE	PART NO.
Crossover	Adjustable	ST20138
Elbow	Adjustable	ST20238
Straight/Floor box	Adjustable	ST20338

THE SUPERLIM JUNCTION BOXES HAVE BEEN SPECIFICALLY DESIGNED TO BE USED WITH THE SUPERSLIM 23MM TRUNKING. FLOORBOXES CANNOT BE USED WITH THIS

- * This product is made to order
- * Special sizes upon request

Screed Trunking

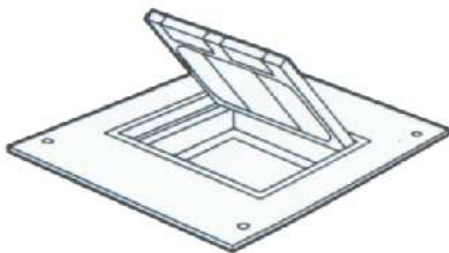
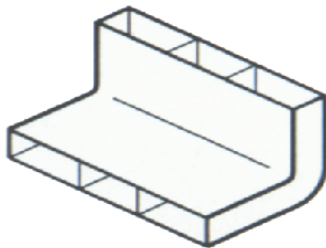
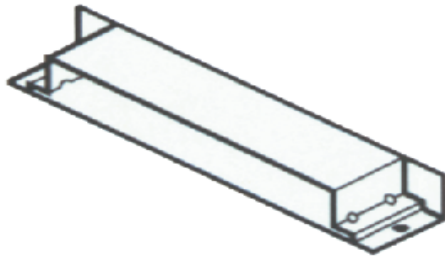
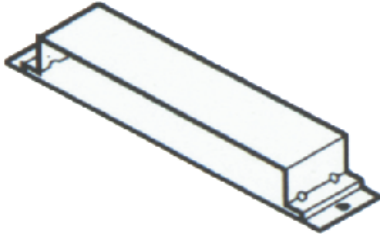
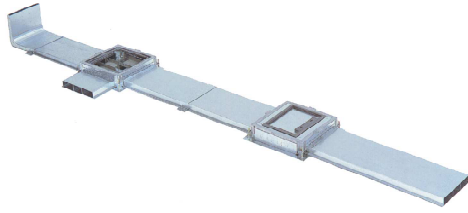

COUPLER	H	PART NO.
Superslim	23	ST20523
Standard	28	ST20528
Large capacity	38	ST20538

END CAP	H	PART NO.
Superslim	23	ST20623
Standard	28	ST20628
Large capacity	38	ST20638

VERTICAL BEND	H	PART NO.
Superslim	23	ST20723
Standard	28	ST20728
Large capacity	38	ST20738

3 COMPARTMENT FLOOR BOX (EMPTY)	PART NO.
N/A	ST20400

USE IN CONJUNCTION WITH THE ADJUSTABLE JUNCTION BOXES ST20338. FLOORBOXES ARE SUPPLIED WITH ALL FIXINGS AND EDGE TRIMMINGS. ACCESSORY MOUNTING PLATES MUST BE ORDERED SEPARATELY.

SINGLE OUTLETS	PART NO.
Steel blank	CL58186
Dome lid	CL1075GRY
Plastic blank	CL1575GRY

USE IN CONJUNCTION WITH THE ADJUSTABLE JUNCTION BOXES ST20338. FLOORBOXES ARE SUPPLIED WITH ALL FIXINGS AND EDGE TRIMMINGS. ACCESSORY MOUNTING PLATES MUST BE ORDERED SEPARATELY.

Screed Trunking

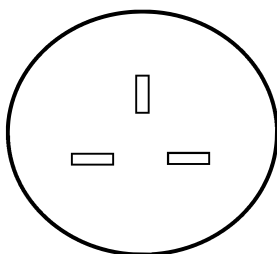
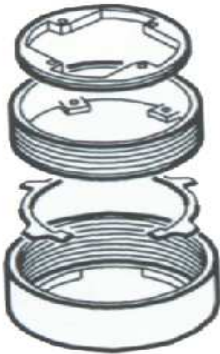

SINGLE OUTLET BOX FOR CONDUIT INSTALLATION	PART NO.
N/A	ST200

KNOCKOUTS: 23MM
HEIGHT ADJUSTMENT: 60 TO 75MM
USE SINGLE OUTLET 24MM SPACERS (PART NO. CL55528) FOR THICKER SCREED

OUTLET BODY FOR IN-SCREED	H	PART NO.
Standard	30-45	ST100
Superslim	26-40	ST50

HEIGHT ADJUSTMENT ABOVE TRUNKING

SPACER	PART NO.
24mm Spacer	CL55528

ACCESSORY PLATES	PART NO.
1 Gang S.O	CL10021
Punched for LJ	CL20021
Blank plate	CL30021

Hole cutters and template data sheets are available from Ackermann on request.

Power Pole





PART NO: SPA28

CMS Power Pole - 2.8m

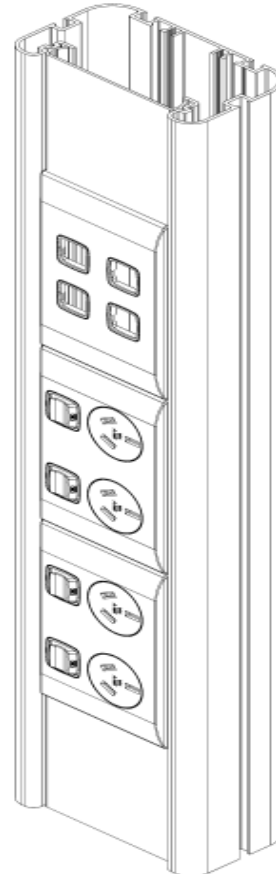
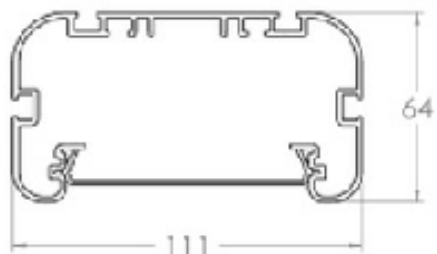
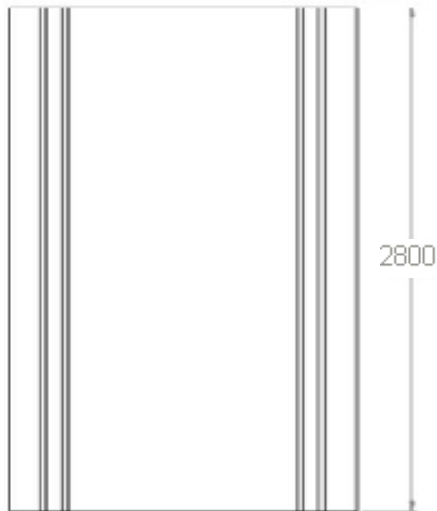
TECHNICAL SPECIFICATIONS:

CMS Power Pole with anodised finish comes with floor and false ceiling mounting kit. Provision included for vertical outlets, segregation conduit.



ITEM NO.		DESCRIPTION	QTY
1		PART NO: SPA28 2.8m Power Pole Anodised finish c/w Ceiling Kit, Floor Bracket, Cover and 3 x Service Mounting boxes	1
2		PART NO: SPA101 Service mounting box	1
3		PART NO: SPA002 T Bar mounting kit	1
4		PART NO: SPA003 Floor mounting bracket	1
5		PART NO: SPA005 Ceiling flange	1
6		PART NO: SPAL200 200mm Pre-cut cover	1

Power Pole





PART NO: SPA33

CMS Power Pole - 3.3m

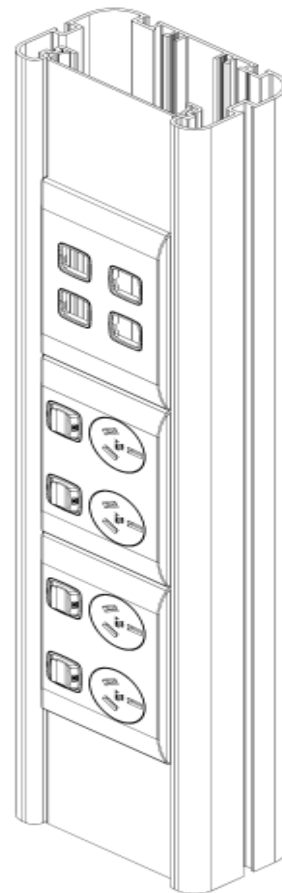
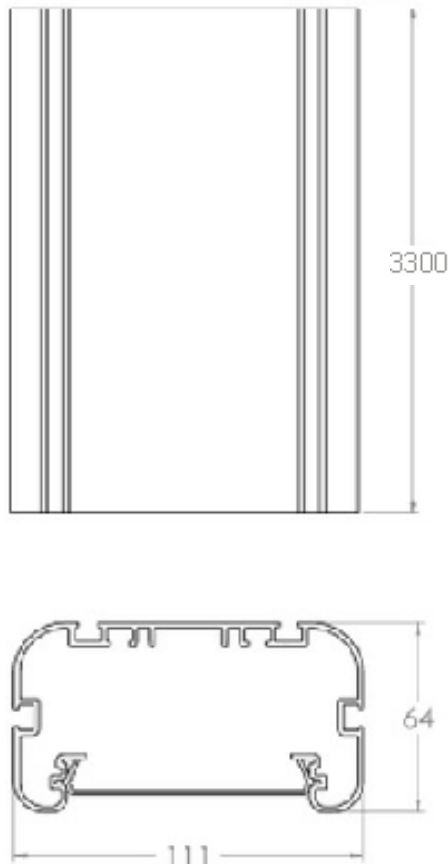
TECHNICAL SPECIFICATIONS:

CMS Power Pole with anodised finish comes with floor and false ceiling mounting kit. Provision included for vertical outlets, segregation conduit.



ITEM NO.		DESCRIPTION	QTY
1		PART NO: SPA33 3.3m Power Pole Anodised finish c/w Ceiling Kit, Floor Bracket, Cover and 3 x Service Mounting boxes	1
2		PART NO: SPA101 Service mounting box	1
3		PART NO: SPA002 T Bar mounting kit	1
4		PART NO: SPA003 Floor mounting bracket	1
5		PART NO: SPA005 Ceiling flange	1
6		PART NO: SPAL200 200mm Pre-cut cover	1

Totem Power Pole

PART NO: SPT06AN

CMS Power Pole - Floor to Desk solution - 670mm

TECHNICAL SPECIFICATIONS:

CMS Totem power pole with anodised finish comes with floor and desk mounting kit. Segregation plate included.

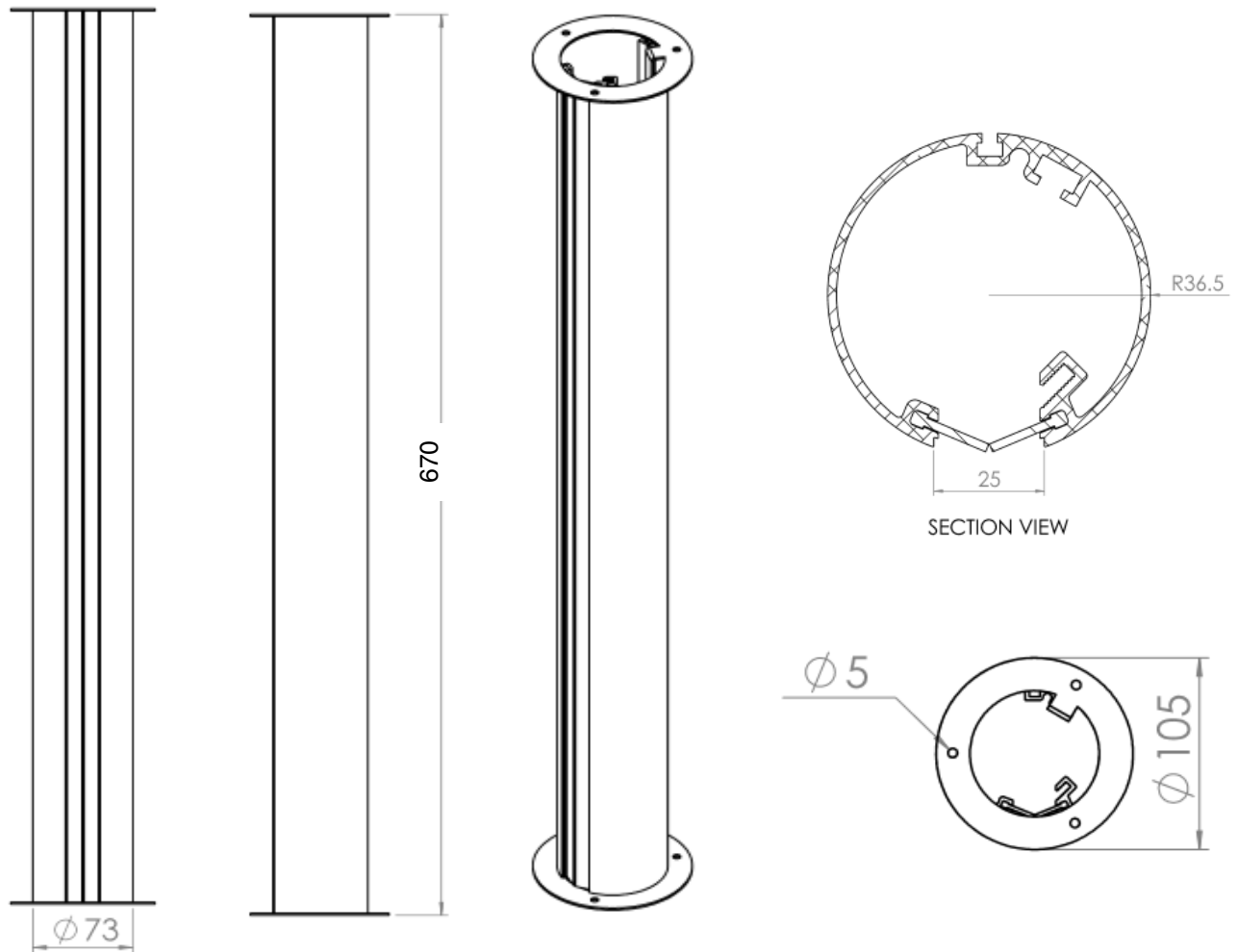

ITEM NO.	DESCRIPTION	QTY
1	PART NO: SPT06AN 670mm Power pole anodised finish c/w floor and desk mounting bracket and cover	1
2	PART NO: SPTFB Floor mounting box	1
3	PART NO: SPTDB Under desk mounting bracket	1
4	PART NO: SPTLID02 200mm Pre-cut cover	1
5	PART NO: AXCD Floor access grommet	1

Totem Power Pole

PART NO: SPT21AN

CMS Power Pole - Ceiling to Desk solution - 2.1m

TECHNICAL SPECIFICATIONS:

CMS Totem power pole with anodised finish comes with ceiling and desk mounting kit. Segregation plate included.

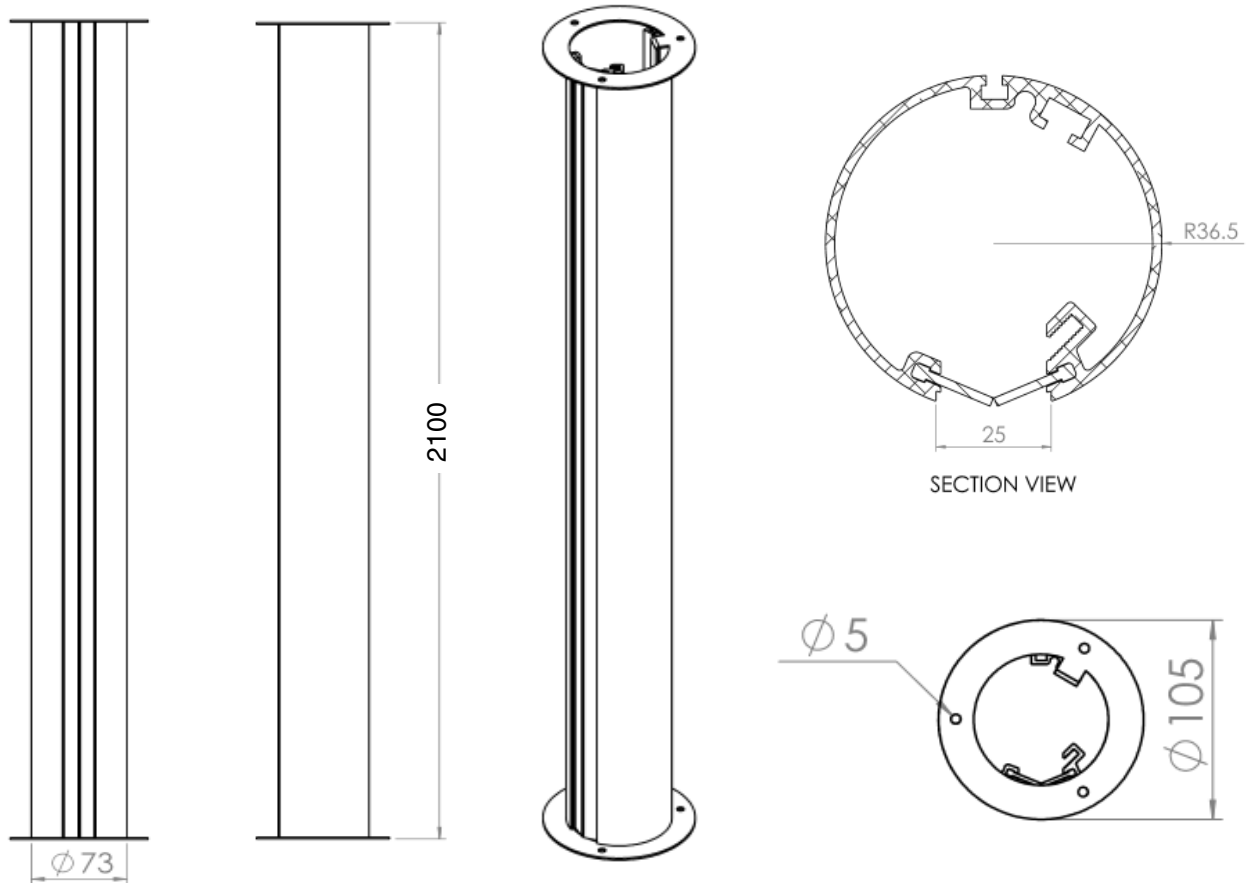

ITEM NO.	DESCRIPTION	QTY
1	PART NO: SPT21AN 2.1m Desk to ceiling power pole anodised finish c/w ceiling kit, mounting bracket, desk grommet and cover	1
2	PART NO: SPTFB Floor mounting box	1
3	PART NO: SPTDB Under desk mounting bracket	1
4	PART NO: SPTLID02 200mm Pre-cut cover	1
5	PART NO: AXCD Ceiling flange	1
6	PART NO: AXCD Floor access grommet	1
7	PART NO: SPTB21 2.1M Brush strip	1

Totem Power Pole

PART NO: SPT28AN

CMS Power Pole - Floor to Ceiling solution - 2.8m

TECHNICAL SPECIFICATIONS:

CMS Totem power pole with anodised finish comes with floor and ceiling mounting kit. Segregation plate included.

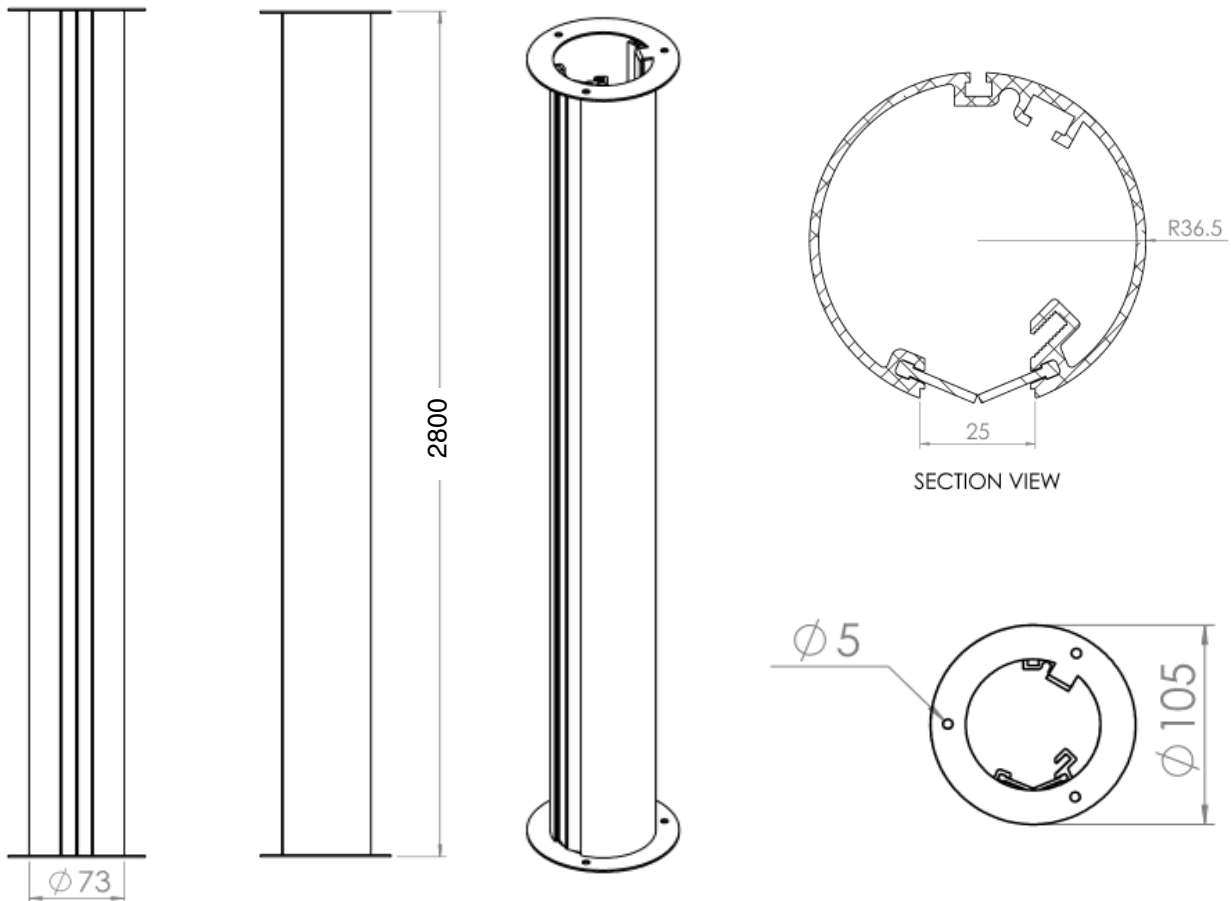

ITEM NO.	DESCRIPTION	QTY
1	PART NO: SPT28AN 2.8m Power pole anodised finish c/w ceiling kit, floor bracket and cover	1
2	PART NO: SPTFB Floor mounting box	1
3	PART NO: AXC Ceiling flange	1
4	PART NO: AXCD Floor access grommet	1
5	PART NO: SPTDB Under desk mounting bracket	1
6	PART NO: SPTLID02 200mm Pre-cut cover	1
7	PART NO: SPTB28 2.8M Brush strip	1

Totem Power Pole

PART NO: SPT33AN

CMS Power Pole - Floor to Ceiling solution - 3.3m

TECHNICAL SPECIFICATIONS:

CMS Totem power pole with anodised finish comes with floor and ceiling mounting kit. Segregation plate included.

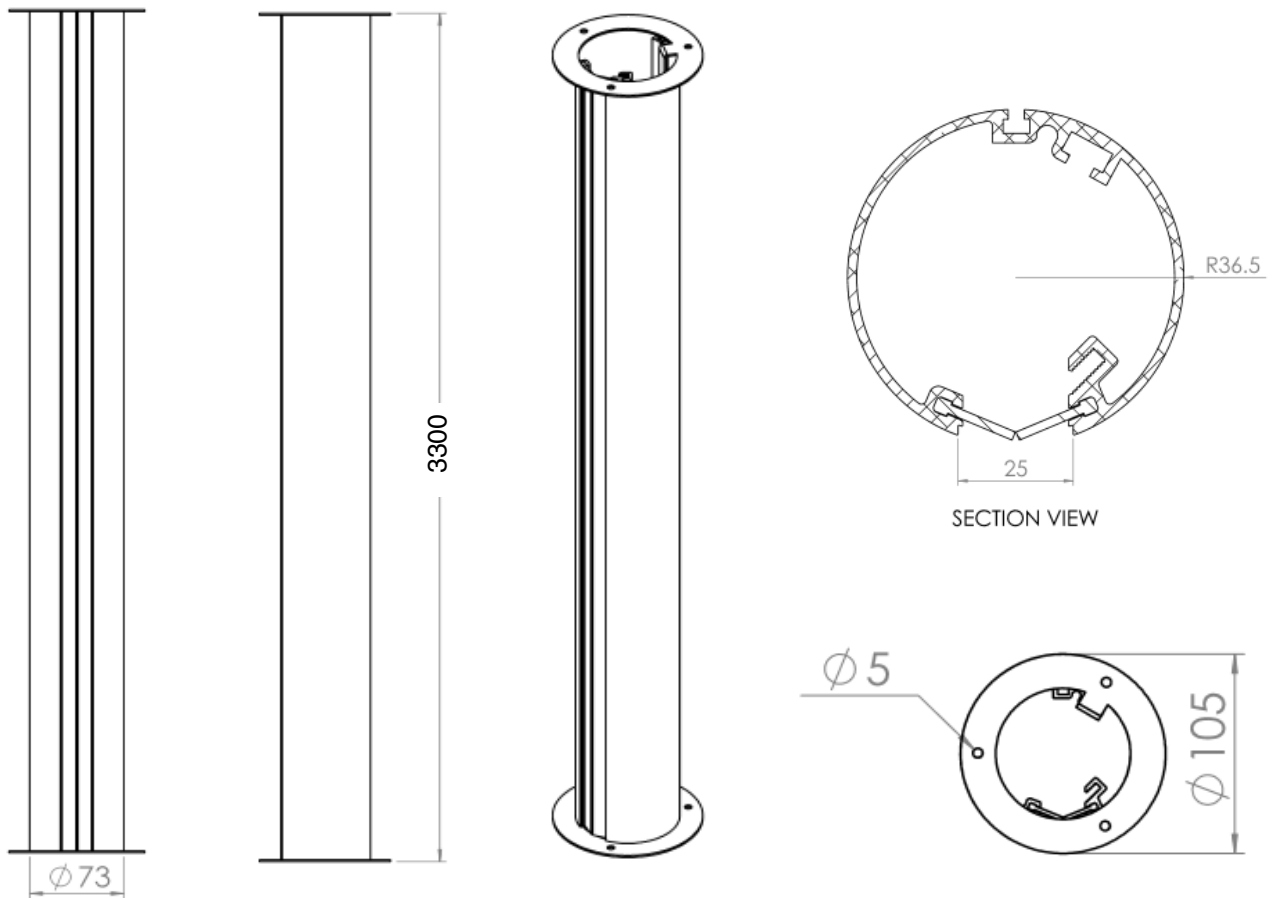

ITEM NO.	DESCRIPTION	QTY
1	PART NO: SPT33AN 3.3m Power pole anodised finish c/w ceiling kit, floor bracket and cover	1
2	PART NO: SPTFB Floor mounting box	1
3	PART NO: AXC Ceiling flange	1
4	PART NO: AXCD Floor access grommet	1
5	PART NO: SPTDB Under desk mounting bracket	1
6	PART NO: SPTLID02 200mm Pre-cut cover	1
7	PART NO: SPTB33 3.3M Brush strip	1

Centrepoint Series II

PART NO: CPT2-02U -

CMS Centre point Power Pole - Under Desk solution - 300mm

TECHNICAL SPECIFICATIONS:

CMS Centrepoint power pole with anodised finish comes with desk mounting kit. Segregation plate included.

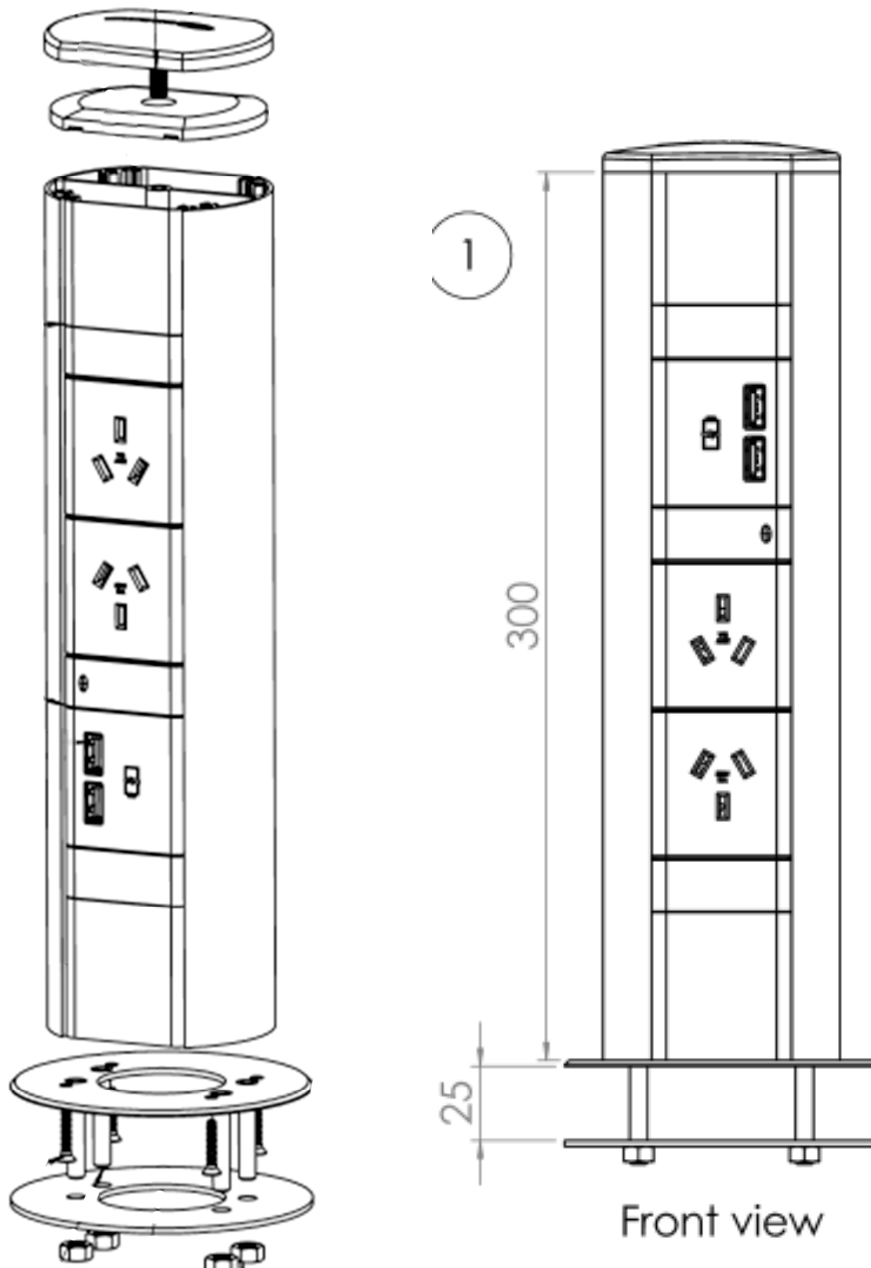

ITEM NO.	DESCRIPTION	QTY
1	PART NO: CPT2-02U 300mm Power pole anodised finish, desk flange mount c/w 2 x Auto switch GPO and USB	1

Centrepoint Series II

PART NO: CPT2FD

CMS Centre point Power Pole - Floor to Desk solution - 720mm

TECHNICAL SPECIFICATIONS:

CMS Centrepoint power pole with anodised finish comes with floor and under desk mounting kit. Segregation plate included.

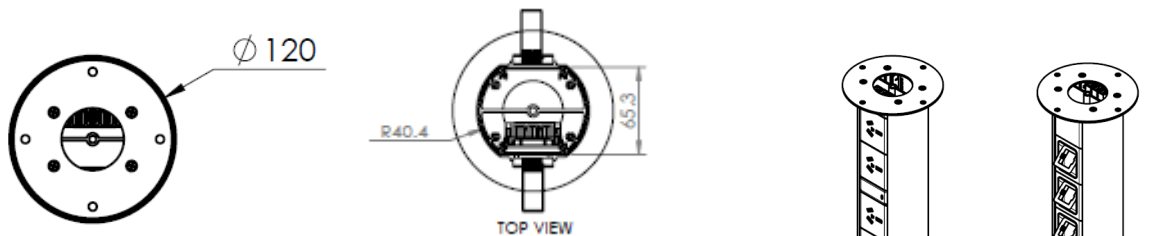
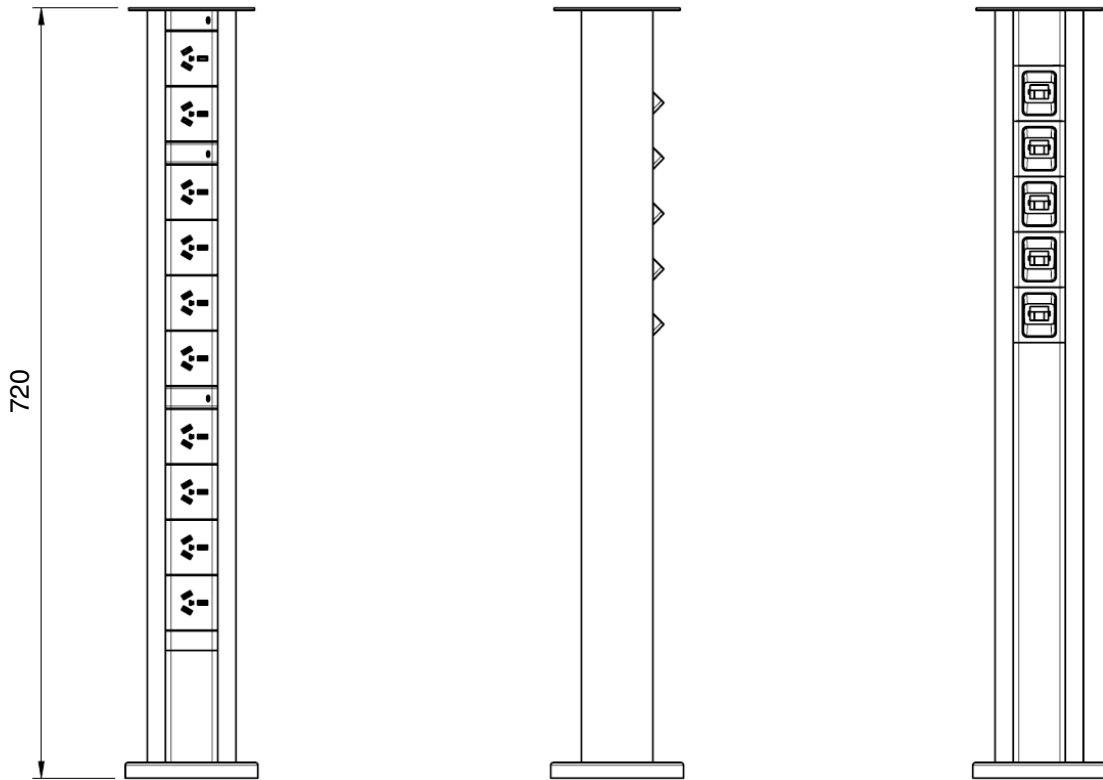

ITEM NO.	DESCRIPTION	QTY
1	PART NO: CPT2FD 720mm Floor to workstation power pole anodised finish c/w floor bracket, cover, under desk mounting bracket	1
2	PART NO: CPT2B Floor mounting bracket including shroud	1
3	PART NO: CPT2D Underdesk mounting bracket	1

Centrepoint Series II

PART NO: CPT2FS

CMS Centre point Power Pole - Free Standing solution - 900mm

TECHNICAL SPECIFICATIONS:

CMS Centrepoint power pole with anodised finish comes with floor bracket and cover.

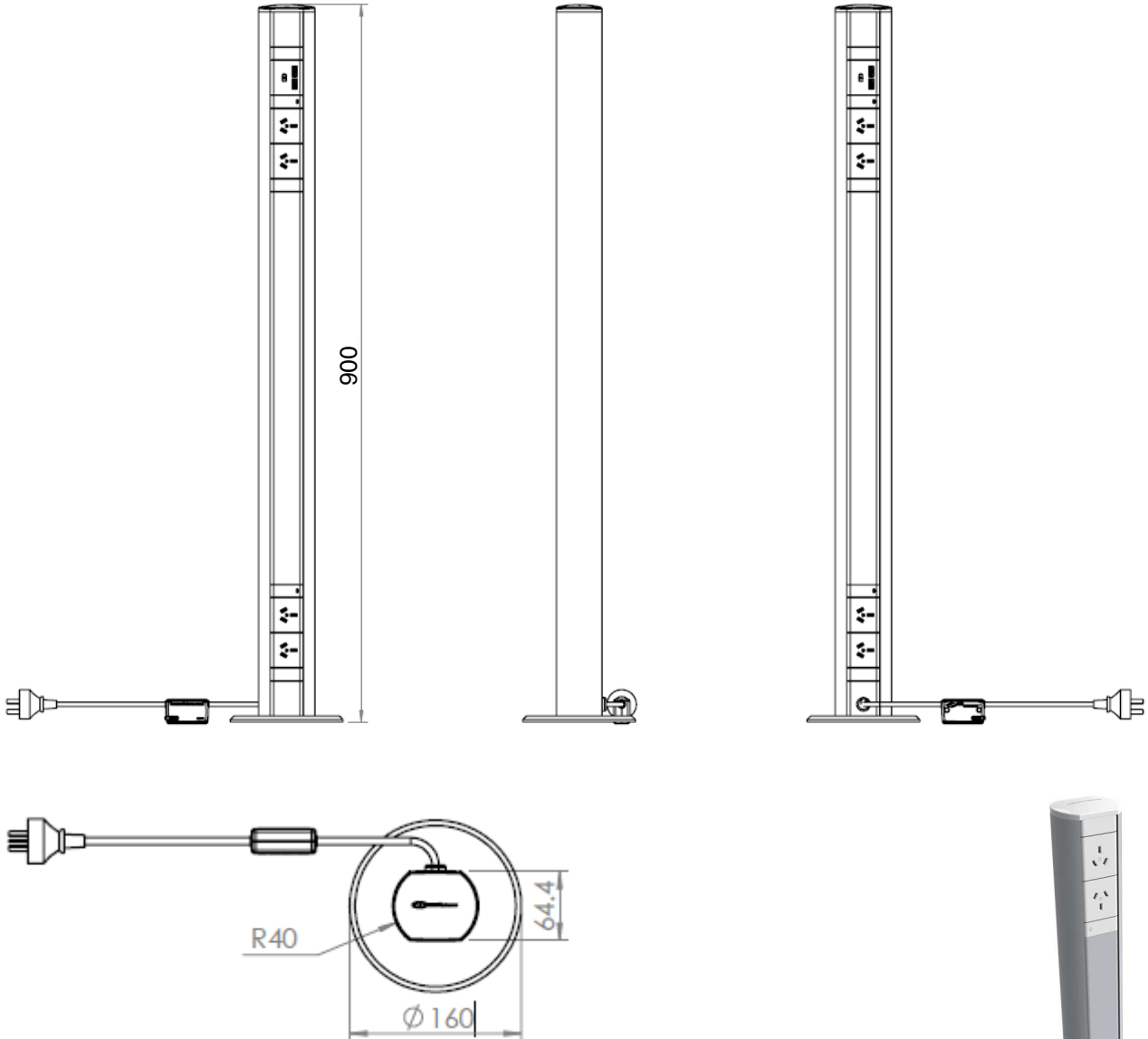

ITEM NO.	DESCRIPTION	QTY
1	PART NO: CPT2FD 720mm Floor to workstation power pole anodised finish c/w floor bracket, cover, under desk mounting bracket	1
2	PART NO: CPT2B Floor mounting bracket including shroud	1
3	PART NO: CPT2D Underdesk mounting bracket	1

Centrepoint Series II

PART NO: CPT2CW

CMS Centre point Power Pole - Ceiling to Workstation solution - 2.1m

TECHNICAL SPECIFICATIONS:

CMS Centrepoint power pole with anodised finish comes with ceiling and desk mounting kit. Segregation plate included.

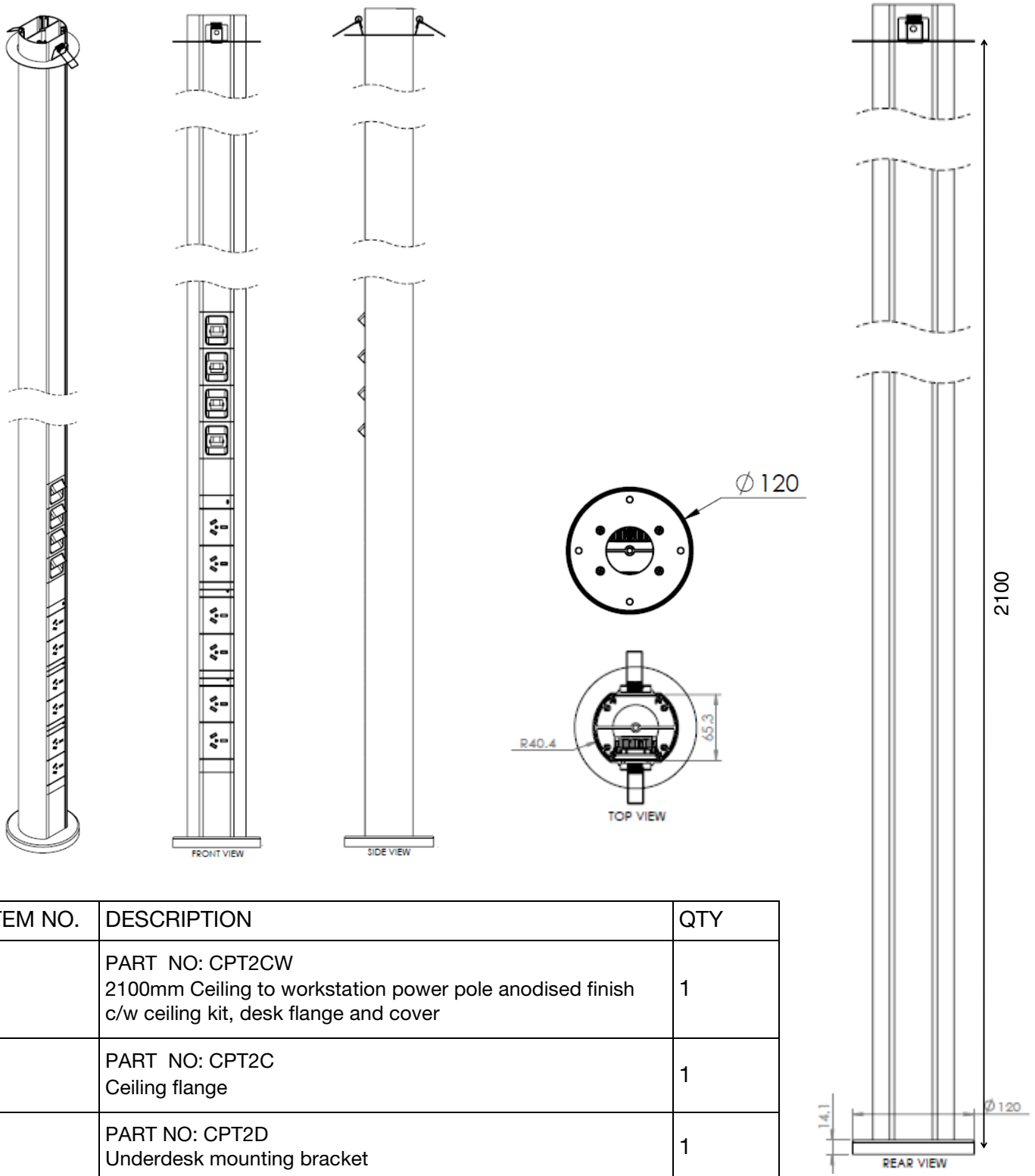

ITEM NO.	DESCRIPTION	QTY
1	PART NO: CPT2CW 2100mm Ceiling to workstation power pole anodised finish c/w ceiling kit, desk flange and cover	1
2	PART NO: CPT2C Ceiling flange	1
3	PART NO: CPT2D Underdesk mounting bracket	1

Centrepoint Series II

PART NO: CPT2CF

CMS Centre point Power Pole - Ceiling to Floor solution - 2800mm

TECHNICAL SPECIFICATIONS:

CMS Centrepoint power pole with anodised finish comes with ceiling and floor mounting kit. Segregation plate included.

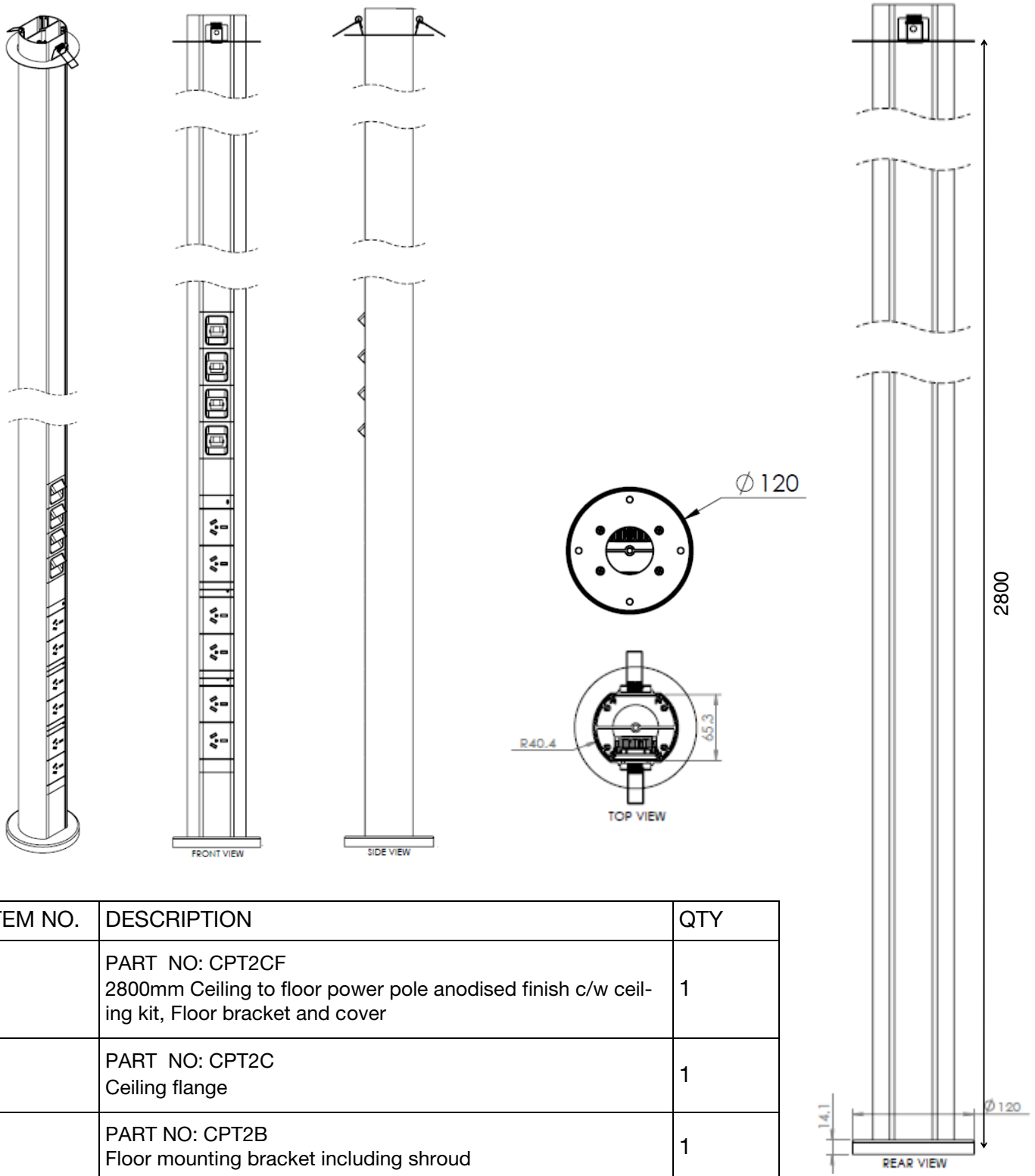

ITEM NO.	DESCRIPTION	QTY
1	PART NO: CPT2CF 2800mm Ceiling to floor power pole anodised finish c/w ceiling kit, Floor bracket and cover	1
2	PART NO: CPT2C Ceiling flange	1
3	PART NO: CPT2B Floor mounting bracket including shroud	1



AUSTRALIA

1300 159 159

NEW ZEALAND

+64 9 582 0776

UNITED KINGDOM

+44 (0) 203 356 9709

SINGAPORE

+65 945 704 61