

2015-16 Floor box Application Guide

Wiring + Power
Solutions

cmselectra.com

About CMS

CMS Electracom is an Australasian global leader supplying innovative wiring solutions to commercial and industrial applications.

CMS Electracom commenced business in 1979 supplying custom made cable harnesses and wiring assemblies for the data and electrical industry.

Our head office and modern manufacturing facility is located in the Melbourne suburb of Dandenong. Combined with sales operations in Sydney, Brisbane, Perth, New Zealand, UK, and an Australasian wide distribution network.

We have, over recent years been expanding our range of electrical products used in the commercial building sector and are committed to continued expansion in this area. CMS offers you a wealth of expertise in softwiring and power solutions for commercial buildings, and the flexibility of customisation to assist in fulfilling any special requirements you may have.



Modular Wiring

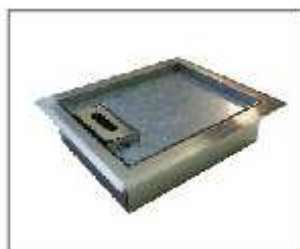

Floor Boxes & Floor Outlets



Busbar



Screed Trunking



Power Pole



Dali Lighting



Installation tools



Skirting Duct

Floorbox Overview

CMS Products in Use

Titan Access Power/Softwiring/AV Floorbox

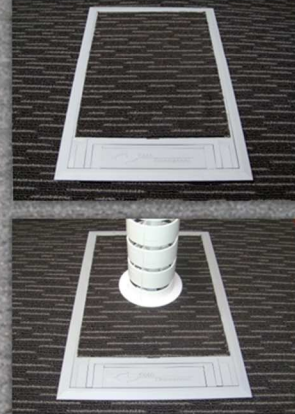

The Range—CMS Floorboxes are determined by its Undercarriage, which are compatible with our range of Polycarbonate, Stainless Steel and Heavy Duty Rhino Lid tops.

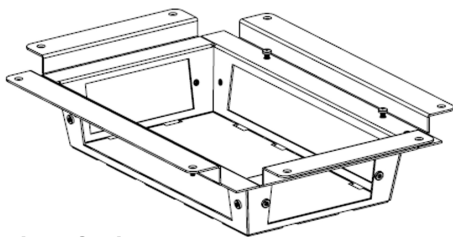

Titan Series

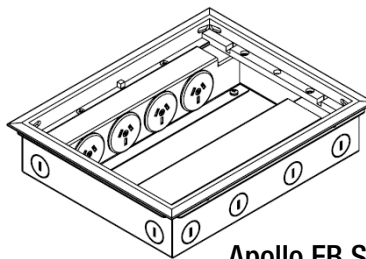

Apollo FB Series

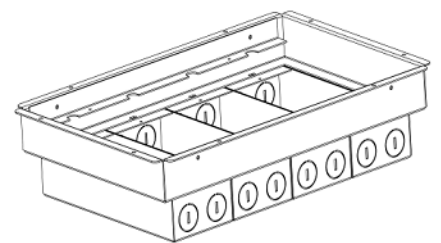

Apollo FL Series

The CMS range of floorboxes allows you to install power, audio, video, telecommunications, and data ports all in one location. CMS Electracom in-house design team provide custom solutions to all projects. Our team of dedicated professionals are trained to work with you in delivering the right wiring and power solution within time and budget.

For your next electrical fit-out requiring Power, Data and AV - Contact our expert Sales team via Email: sales@cmselectra.com or Nationwide sales 1300 159 159

Content

Floorbox Specification Guide Index

Titan Series

- Page 5 Titan Intro
- Page 6 FTA2 Access
- Page 7 FT2CH Inscreed
- Page 8 FT4CH Inscreed
- Page 9 FTA4 Access
- Page 10 FTA4 Low Profile Access
- Page 11 FT4CH Low Profile Inscreed

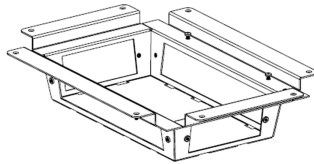

Apollo FL Flush Stainless Steel Series

- Page 12 FLF2080SS
- Page 13 FLF2090SS
- Page 14 FLF2120SS
- Page 15 FLF3080SS
- Page 16 FLF3090SS
- Page 17 FLF3120SS
- Page 18 FLF4080SS
- Page 19 FLF4090SS
- Page 20 FLF4120SS

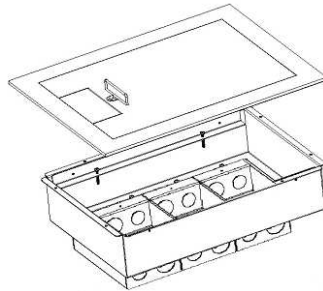

Apollo FL Recessed Series

- Page 21 FL2080
- Page 22 FL2090
- Page 23 FL2120
- Page 24 FL3080
- Page 25 FL3090
- Page 26 FL3120
- Page 27 FL4080
- Page 28 FL4090
- Page 29 FL4120

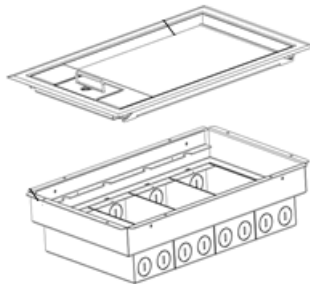

Apollo FL Recessed Stainless Steel

- Page 30 FL2080SS
- Page 31 FL2090SS
- Page 32 FL2120SS
- Page 33 FL3080SS
- Page 34 FL3090SS
- Page 35 FL3120SS
- Page 36 FL4080SS
- Page 37 FL4090SS
- Page 38 FL4120SS

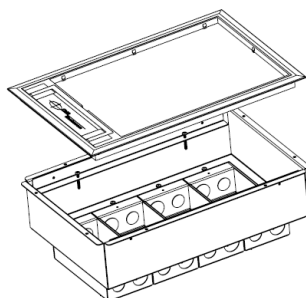

Apollo FB Recessed Series:

- Page 39 FB260
- Page 40 FB280
- Page 41 FB210
- Page 42 FB360
- Page 43 FB460
- Page 44 FB480
- Page 45 FB410

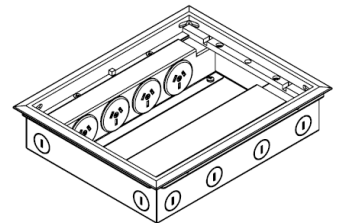

Rhino Heavy-duty Lid Series:

- Page 46 RF2080SS
- Page 47 RF2090SS
- Page 48 RF2120SS
- Page 49 RF4080SS
- Page 50 RF4090SS
- Page 51 RF4120SS

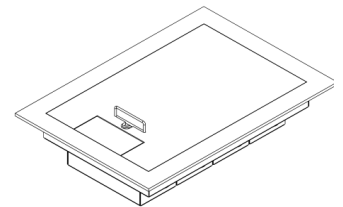

3 Phase Stainless Steel Series:

- Page 52 RF4B5120SS

G1 & G2 Service Outlets Series

- Page 53 G1
- Page 54 G2
- Page 55 G1 - Mini
- Page 56 G1-56

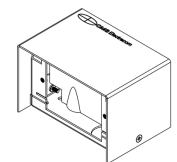

GES2 Recessed Series

- Page 57 GES2

GES2 Stainless Steel Series

- Page 58 GES2

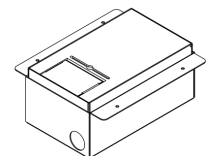

GESRM2 Series

- Page 59 GESRM2B/BE Series
- Page 60 GESRM2/CT



Cablelink Series

- Page 61 Cablelink 1

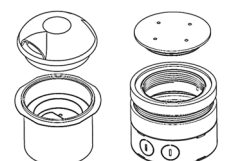

BR1 Series

- Page 62 BR1 Series

Titan Series

CMS Electracom have the largest range of floor boxes in the market.

Manufactured in Australia - the CMS Titan is the latest edition to the CMS Floor box range. The CMS Titan floor box is built with the highest quality delivery many capabilities.

The Titan Floor box is designed with AV, data, electrical trades in mind, ensuring all trades have a floor box that is easy to use and adaptable to the wide variety of products on the market. In the Titan floor box we can accommodate power, data - across the full range, and all AV requirements such as Extron, Kramer, Crestron and AMX.

The Titan floor box comes in various sizes and is suitable for raised floor or in slab applications. The in slab Titan floor box has a proprietary screed box that suits all applications and maintains all required data bend radius. Furthermore, the Titan floor box is a cost-effective product that is fast becoming a market leader when a tough and adaptable floor outlet service is required.

The Titan floor box is designed for maximum flexibility incorporating power, data and AV to suit client requirements. The Titan floor box provides services directly to workstations, conferences, meetings, and training rooms suitable for concrete or computer access floor applications. The Titan floor box has interchangeable face plate to incorporate power and specific brands of data and audio visual components.

The lid incorporates an easy grab lifting handle and an oversized cable exit cap.

A bevelled edge carpet frame and 7mm carpet/tile recessed lid is moulded in hard wearing, high impact, polycarbonate / ABS blend Polyamide with a 2.5mm steel plate fitted for extra strength.

Some of the features include:

- Available in two sizes
- Interchangeable plates
- Branded AV Solutions (Extron, Kramer)
- Easy grab lifting handle
- High impact lid with 7mm recess
- Concrete or Access floor applications

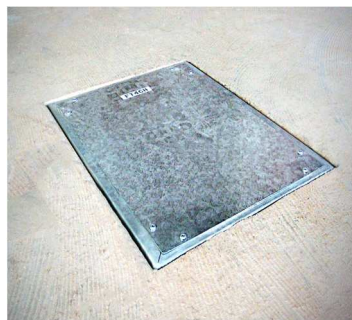

CMS have an in-house engineering design team and an estimating department to assist with your project requirements. We do provide project pricing and the know-how to meet your project deadlines, and most importantly we assist you to achieve your project within budget.

Note: The CMS Titan 65mm deep Titan floor boxes are available in 3 & 4 compartment options. These custom floor boxes are made to order.

For product and specification enquiries about CMS Floor box solutions, please call 1300 159 159 or alternatively email estimating@cmselectra.com.

Floorbox: Titan FTA2 Access Floorbox

PART NO: FTA2

CMS Titan FTA2 Access Floorbox With Lid - 95mm deep

TECHNICAL SPECIFICATIONS:

CMS Titan FTA2 Access floorbox lid has bevelled edge carpet frame with 7mm Carpet/Tile recessed lid. Lid manufactured from poly carbonate/ABS blend Polymide. 2.5mm Steel plate fitted into lid. Easy grab lifting handle with oversized cable exit cap. The Access undercarriage is 95mm deep and constructed from 1.6mm powder coated mild steel. **Load Capacity: 120kg**

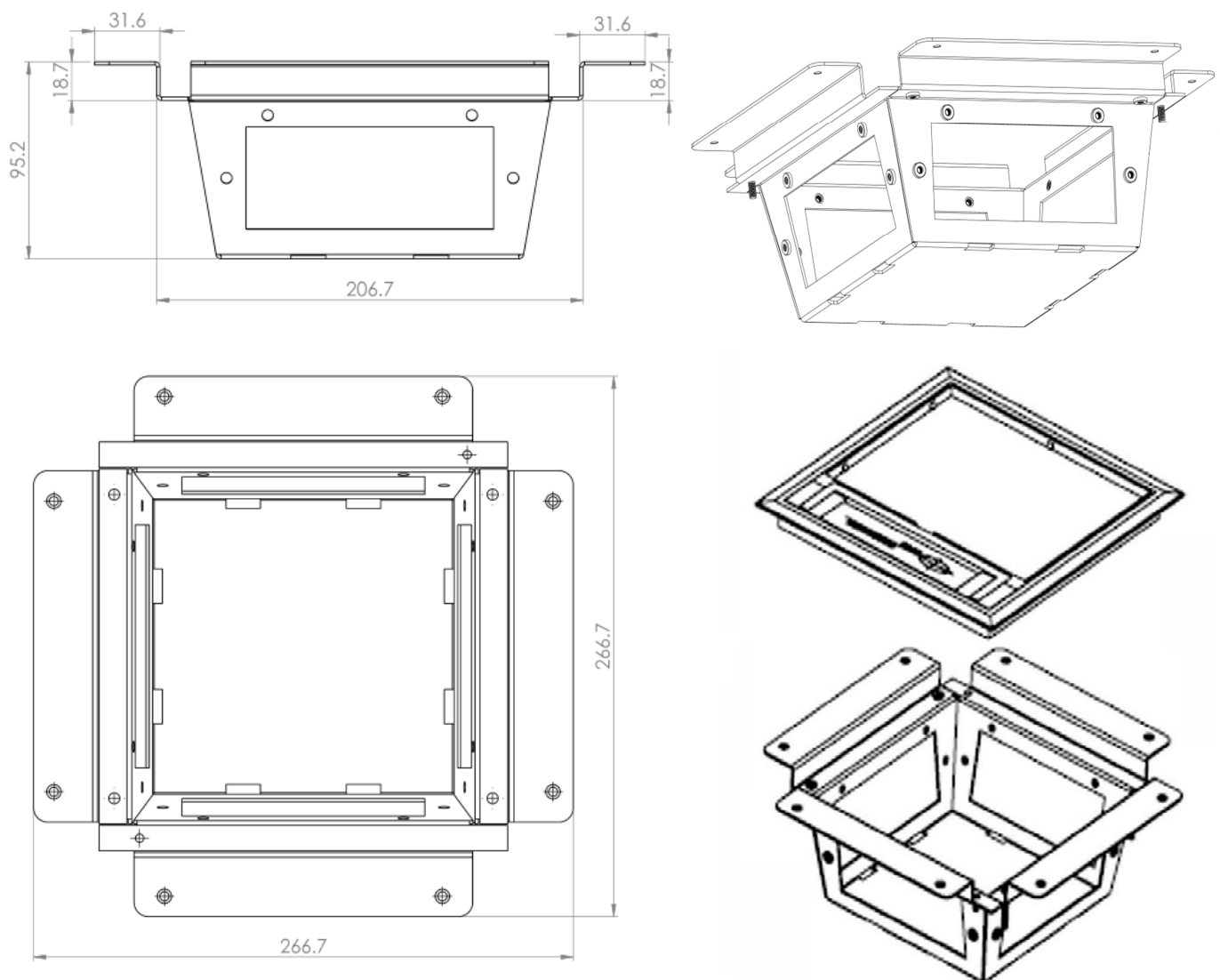

ITEM NO.	DESCRIPTION	QTY
1	Titan FTA2 Access Lid	1
2	Titan FTA2 Access Undercarriage	1
Floorbox cut out dimensions: 210mm x 210mm		

Floorbox: Titan FT2 Inscreed Floorbox

PART NO: FT2CH

CMS Titan FT2CH Inscreed Floorbox - 100mm deep

TECHNICAL SPECIFICATIONS:

CMS Titan FT2 Screed floorbox carcass is manufactured from Galvanised steel with multiple knockouts for conduit on the sides and underneath of the box.

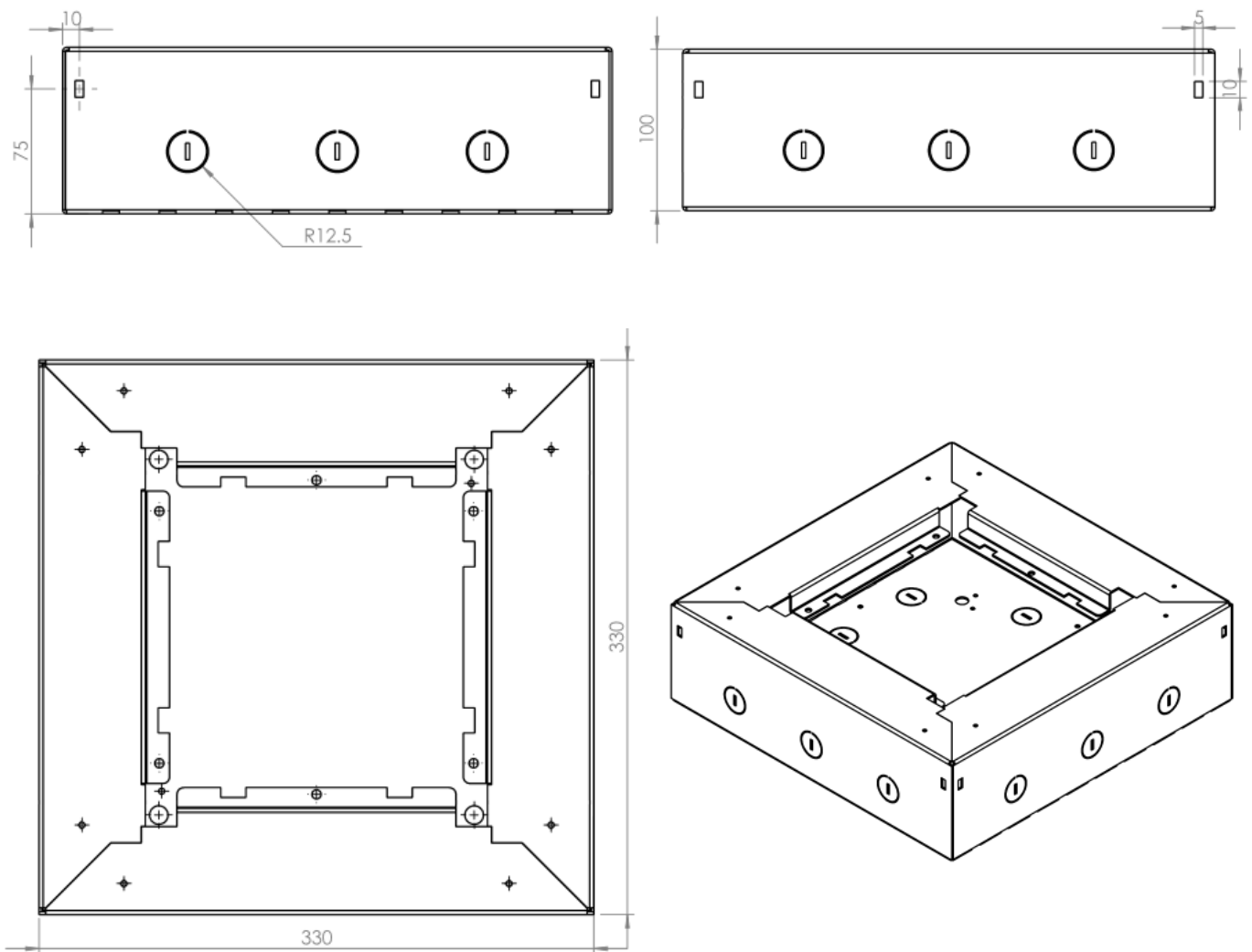

ITEM NO.	DESCRIPTION	QTY
1	Titan FT2 Inscreed Lid	1
2	Titan FT2 Inscreed Undercarriage	1
Floorbox cut out dimensions: 332mm x 332mm		

Floorbox: Titan FT4 Inscreed Floorbox

PART NO: FT4CH

CMS Titan FT4CH Inscreed Floorbox - 100mm deep

TECHNICAL SPECIFICATIONS:

CMS Titan FT4 Screed floorbox carcass is manufactured from Galvanised steel with multiple knockouts for conduit on the sides and underneath of the box.

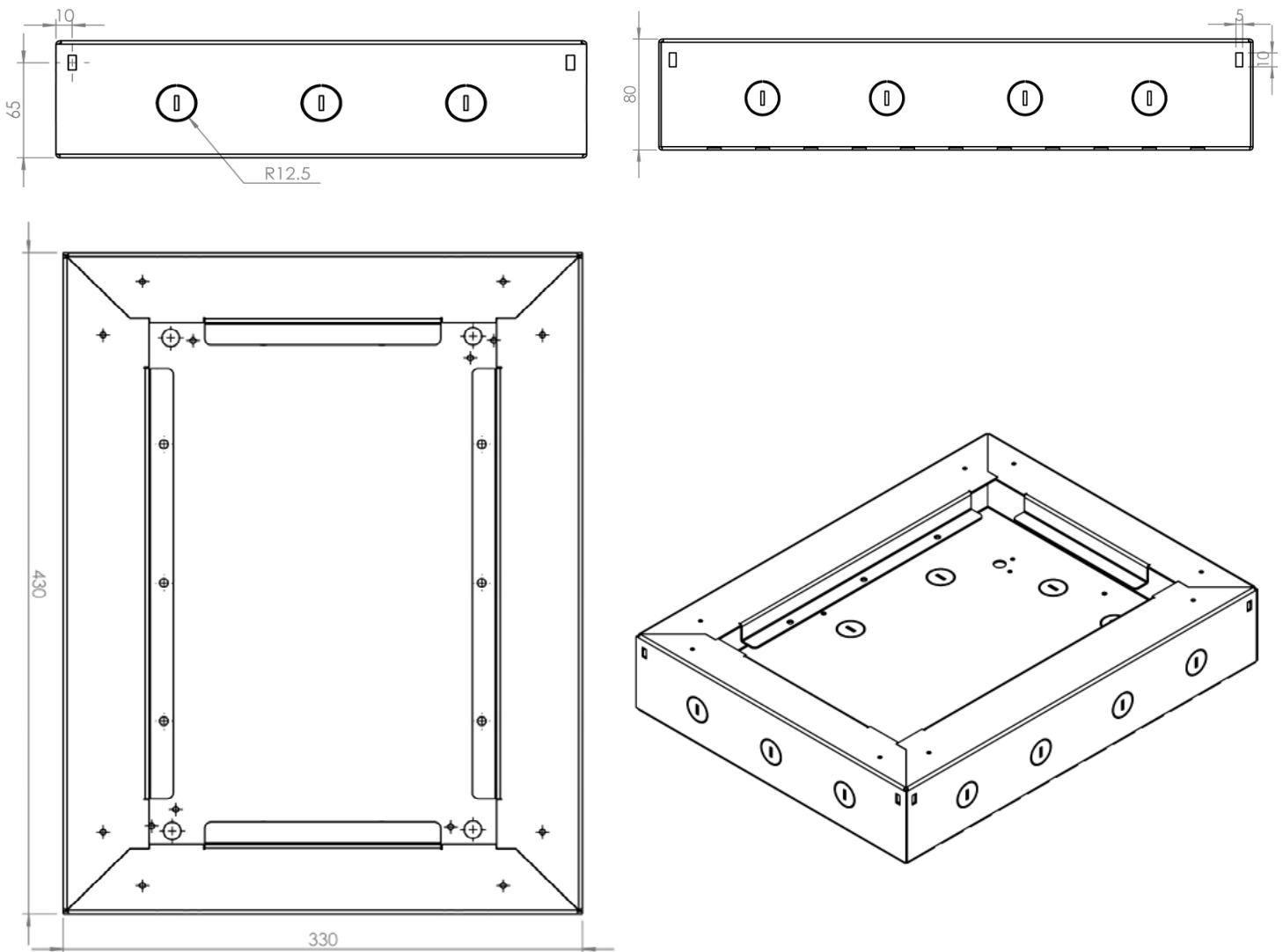

ITEM NO.	DESCRIPTION	QTY
1	Titan FT4 Screed Box	1
Floorbox cut out dimensions: 432mm x 332mm		

Floorbox: Titan FTA4 Access Floorbox

PART NO: FTA4

CMS Titan FTA4 Access Floorbox With Lid - 95mm deep

TECHNICAL SPECIFICATIONS:

CMS Titan FTA4 Access floorbox lid has bevelled edge carpet frame with 7mm Carpet/Tile recessed lid. Lid manufactured from poly carbonate/ABS blend Polymide. 2.5mm Steel plate fitted into lid. Easy grab lifting handle with oversized cable exit cap. The Access undercarriage is 95mm deep and constructed from 1.6mm powder coated mild steel.

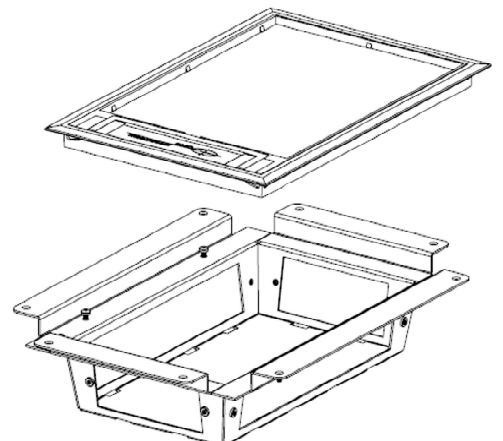
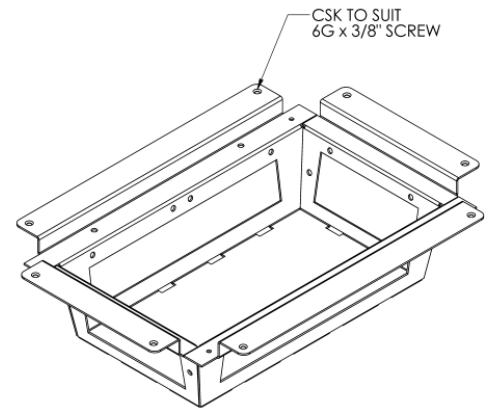
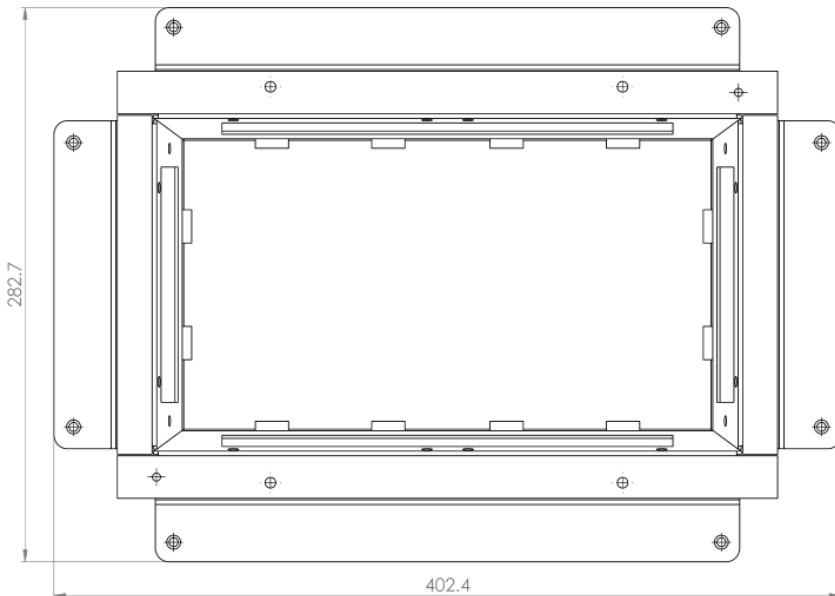
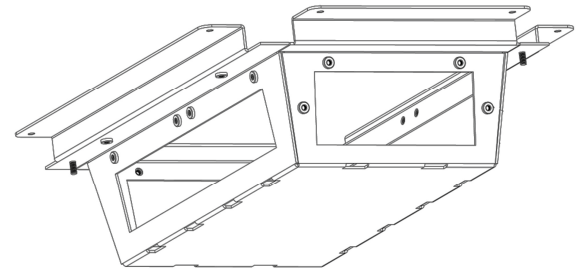
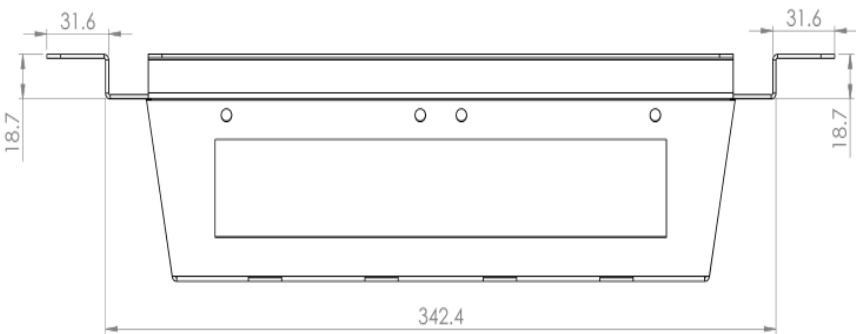

ITEM NO.	DESCRIPTION	QTY
1	Titan FTA4 Access Lid	1
2	Titan FTA4 Access Undercarriage	1
Floorbox cut out dimensions: 345mm x 225mm		

Floorbox: Titan FTA4 Low Profile Access Floorbox

PART NO: FTA4GY75

CMS Titan FTA4GY75 Low Profile Access Floorbox With Lid - 75mm deep

TECHNICAL SPECIFICATIONS:

CMS Titan FTA4GY75 Access floorbox lid has bevelled edge carpet frame with 7mm Carpet/Tile recessed lid. Lid manufactured from poly carbonate/ABS blend Polymide. 2.5mm Steel plate fitted into lid. Easy grab lifting handle with oversized cable exit cap. The Access undercarriage is 75mm deep and constructed from 1.6mm powder coated mild steel.

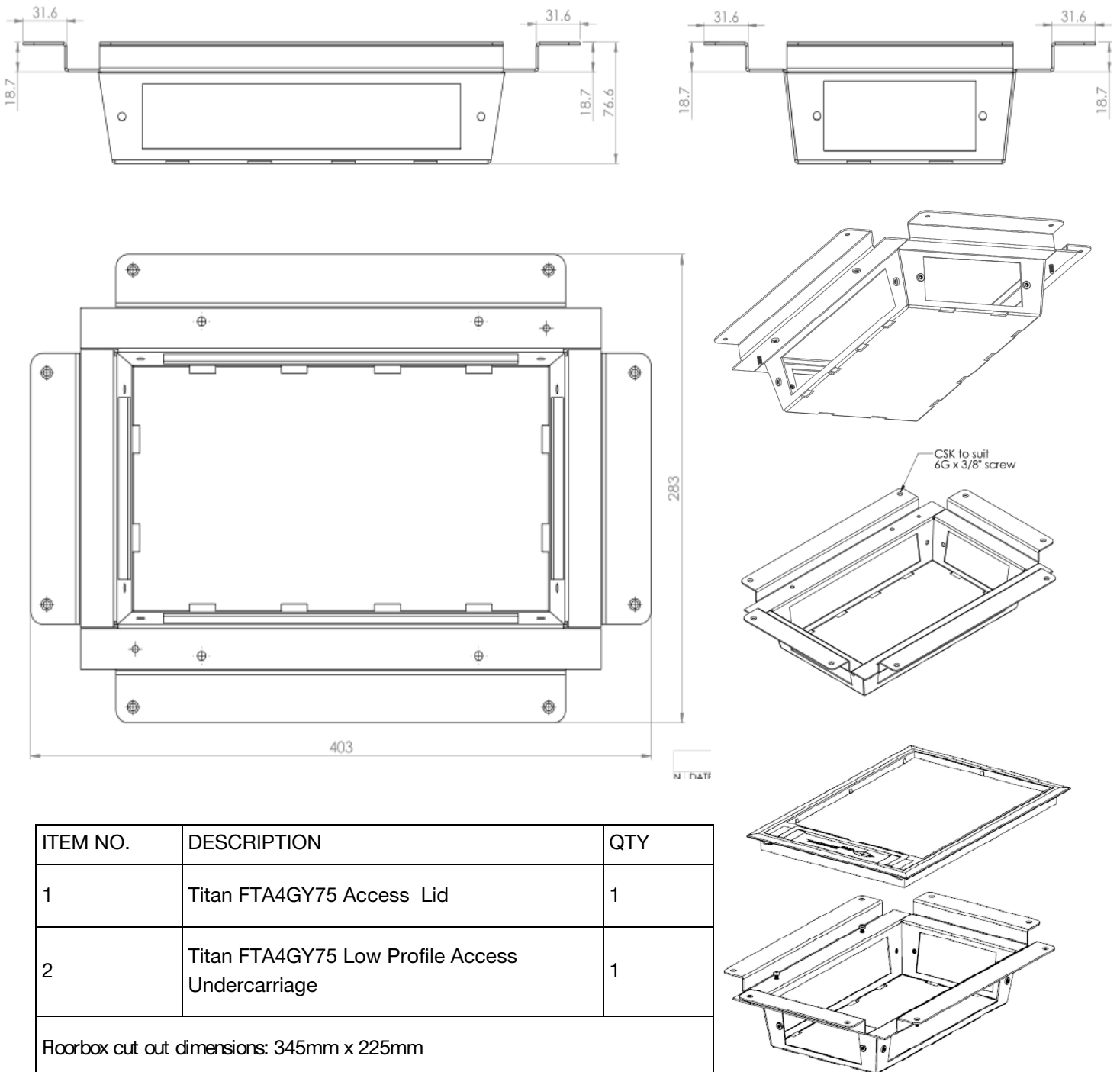

ITEM NO.	DESCRIPTION	QTY
1	Titan FTA4GY75 Access Lid	1
2	Titan FTA4GY75 Low Profile Access Undercarriage	1
Floorbox cut out dimensions: 345mm x 225mm		

Floorbox: Titan FT4CH80 Low Profile Inscreed Floorbox

PART NO: FT4CH80

CMS Titan FT4CH80 Low Profile Inscreed Floorbox - 80 deep

TECHNICAL SPECIFICATIONS:

CMS Titan FT4CH80 Screed floorbox carcass is manufactured from Galvanised steel with multiple knockouts for conduit on the sides and underneath of the box.

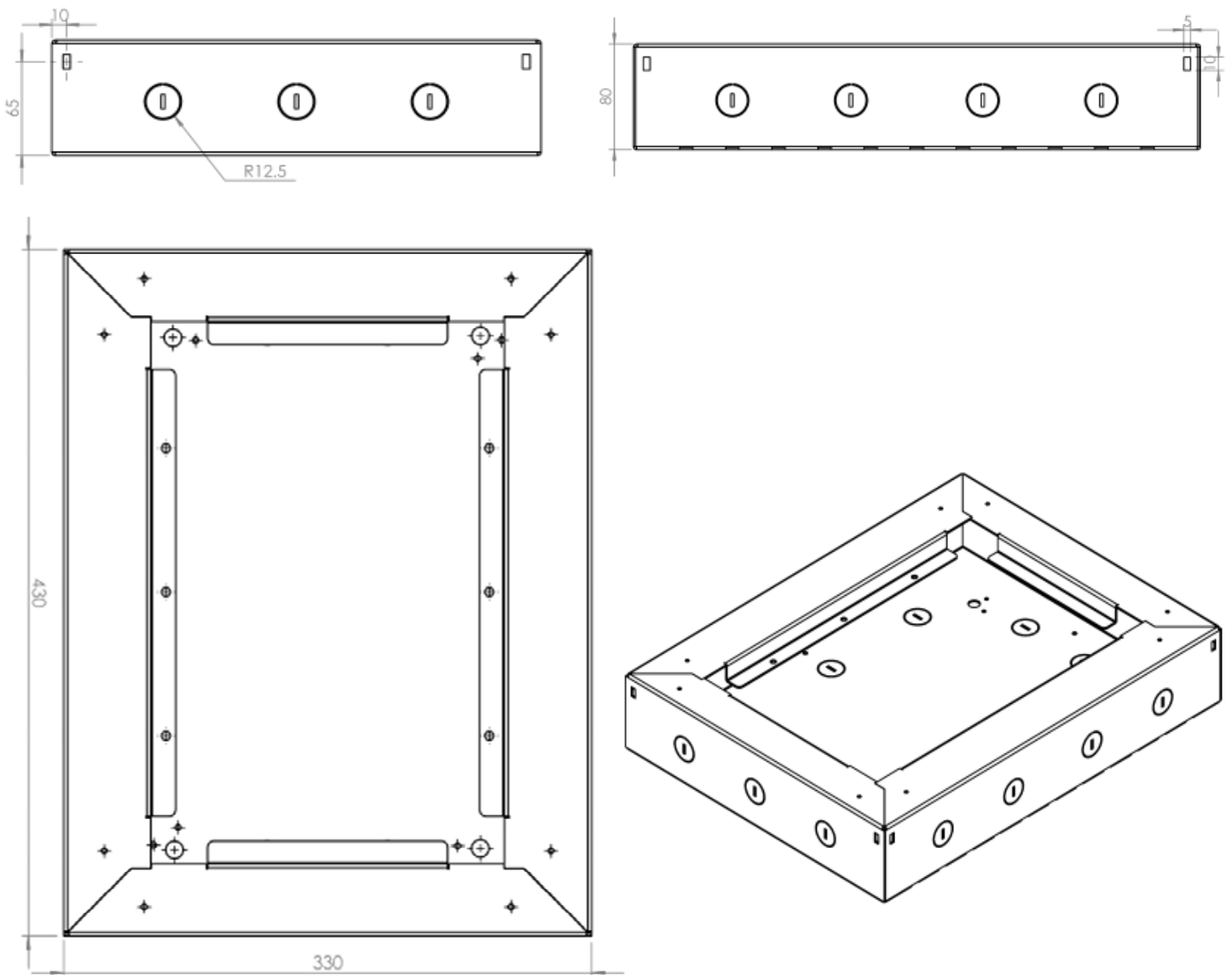

ITEM NO.	DESCRIPTION	QTY
1	Titan FT4 Low Profile Inscreed	1

Floorbox cut out dimensions: 432mm x 332mm

Floorbox: Apollo FL Flush Stainless Steel Series

PART NO: FLF2080SS

CMS Apollo FL Flush Stainless Steel Floorbox - 2 Compartment, 80mm deep

TECHNICAL SPECIFICATIONS:

CMS 2 compartment , 80mm deep Apollo floorbox flush mount bevelled lid is manufactured from 5mm stainless steel and is suitable in applications requiring additional strength and easily installed into a concrete or timber floor. Accessory boxes come in galvanised steel. The chassis and mounting plates are constructed from powder coated sheet steel with multiple knockouts for conduit. **Load Capacity: 150kg**

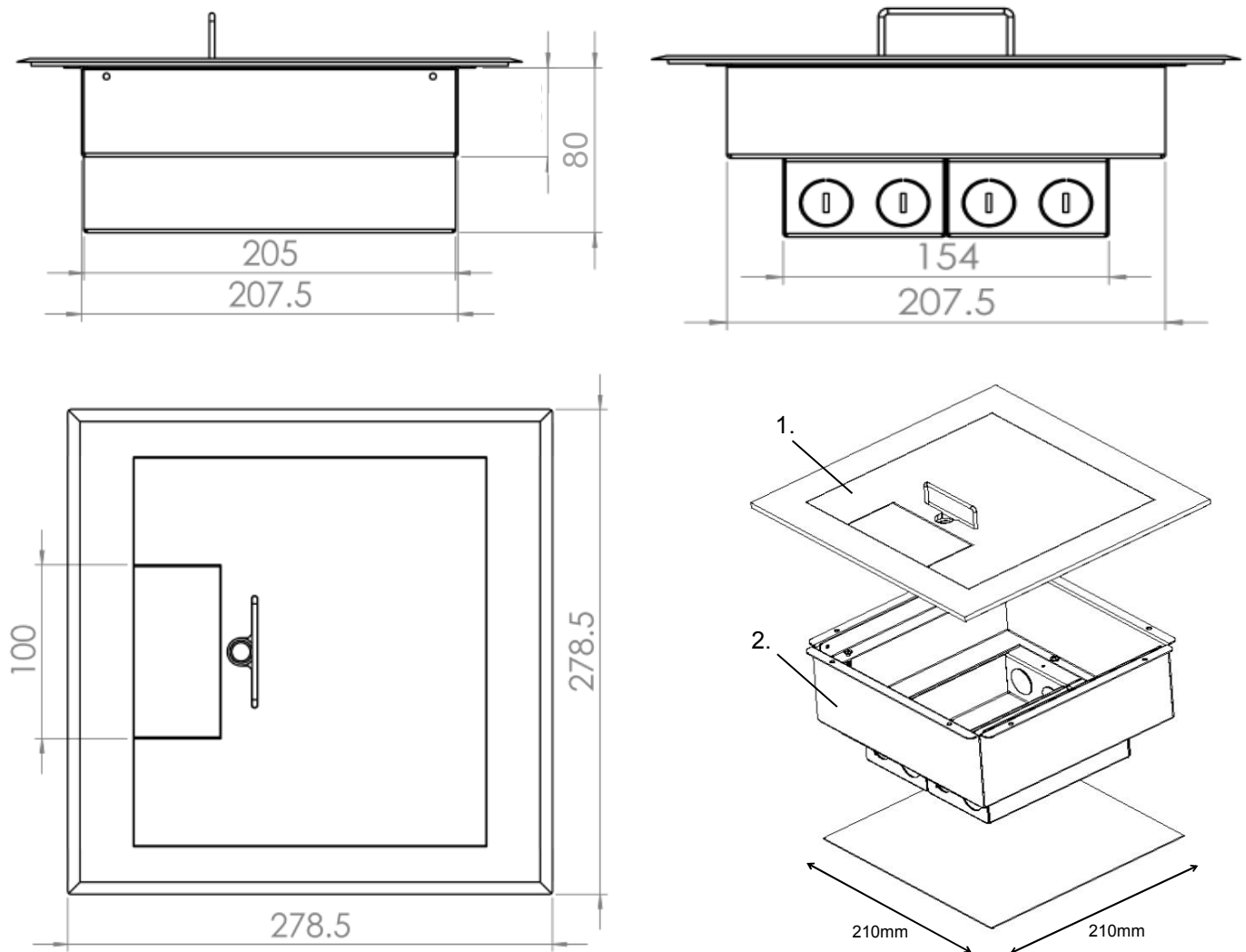

ITEM NO.	DESCRIPTION	QTY
1	APOLLO FL FLUSH STAINLESS STEEL BEVELLED LID	1
2	APOLLO FL SS 80MM UNDERCARRIAGE	1
Floorbox cut out dimensions: 210mm X 210mm		

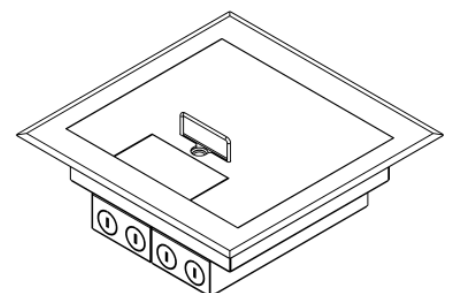

Floorbox: Apollo FL Flush Stainless Steel Series

PART NO: FLF2090SS

CMS Apollo FL Flush Stainless Steel Floorbox - 2 Compartment, 90mm deep

TECHNICAL SPECIFICATIONS:

CMS 2 compartment , 90mm deep Apollo floorbox flush mount bevelled lid is manufactured from 5mm stainless steel and is suitable in applications requiring additional strength and easily installed into a concrete or timber floor. Accessory boxes come in galvanised steel. The chassis and mounting plates are constructed from powder coated sheet steel with multiple knockouts for conduit. **Load Capacity: 150kg**

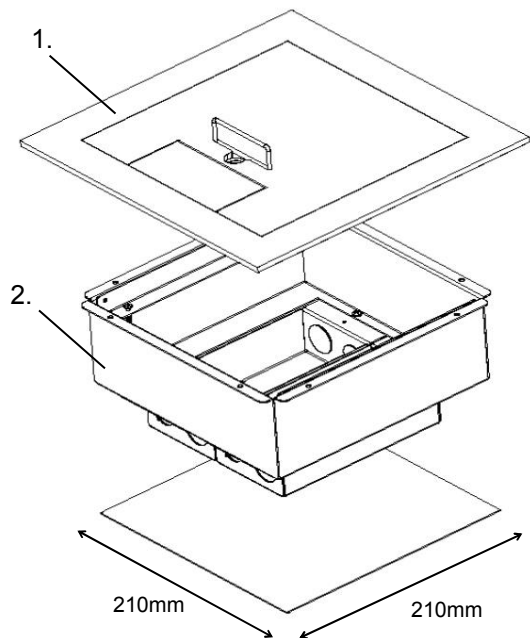
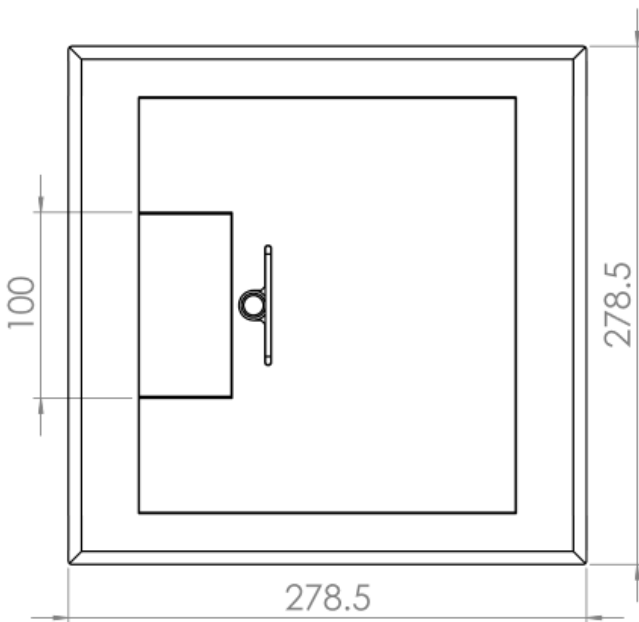
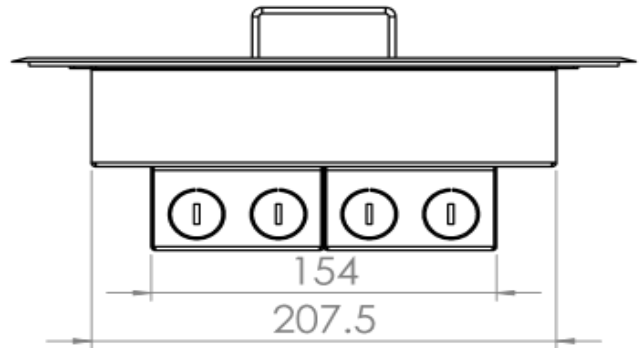
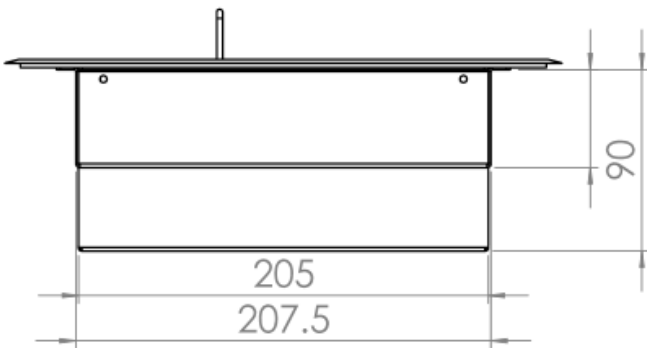

ITEM NO.	DESCRIPTION	QTY
1	APOLLO FL FLUSH STAINLESS STEEL BEVELLED LID	1
2	APOLLO FL SS 90MM UNDERCARRIAGE	1
Floorbox cut out dimensions: 210mm X 210mm		

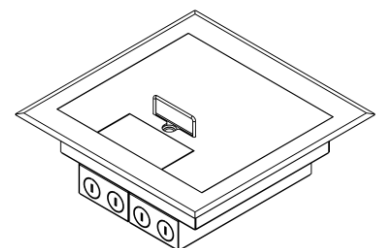

Floorbox: Apollo FL Flush Stainless Steel Series

PART NO: FLF2120SS

CMS Apollo FL Flush Stainless Steel Floorbox - 2 Compartment, 120mm deep

TECHNICAL SPECIFICATIONS:

CMS 2 compartment , 120mm deep Apollo floorbox flush mount bevelled lid is manufactured from 5mm stainless steel and is suitable in applications requiring additional strength and easily installed into a concrete or timber floor. Accessory boxes come in galvanised steel. The chassis and mounting plates are constructed from powder coated sheet steel with multiple knockouts for conduit. **Load Capacity: 150kg**

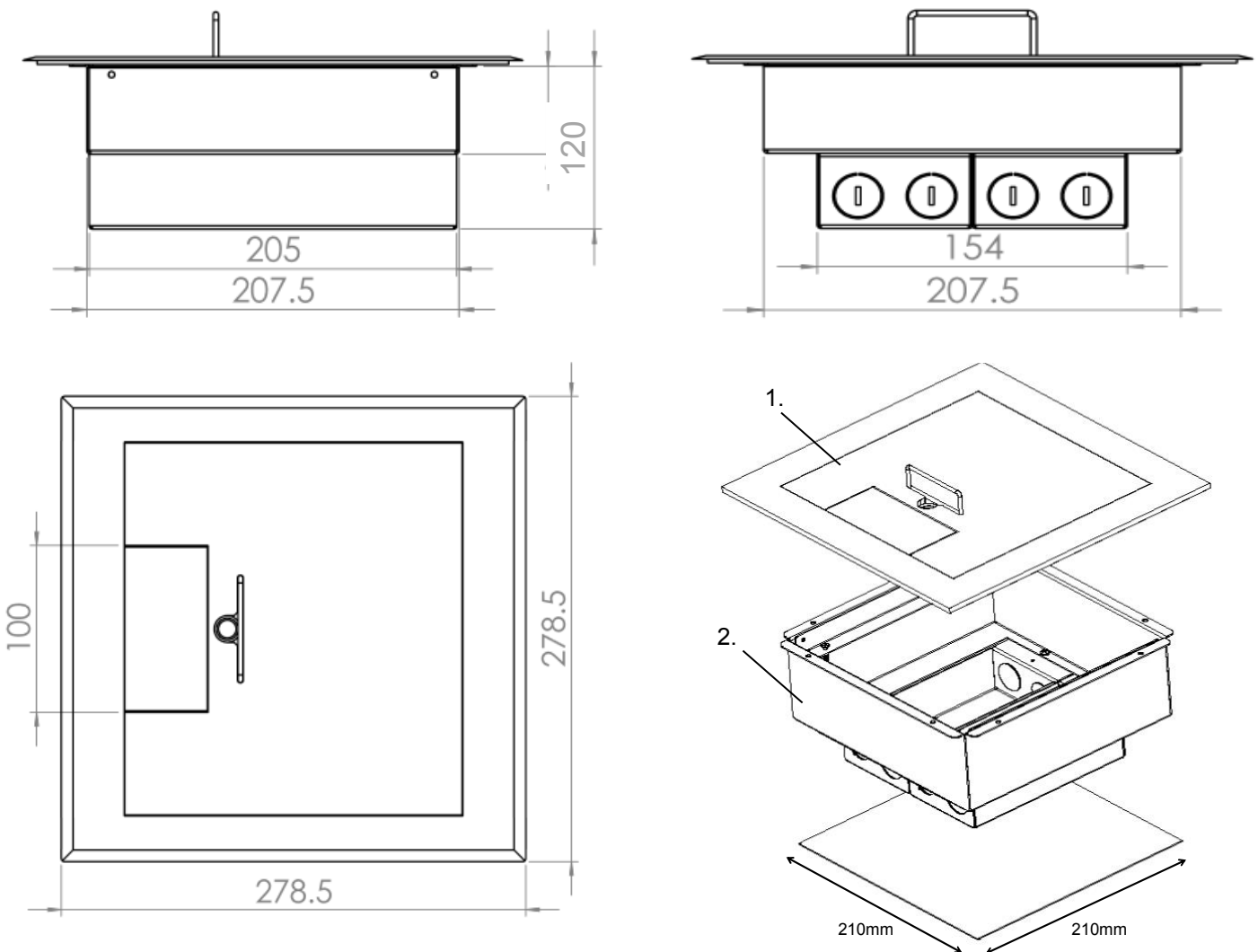

ITEM NO.	DESCRIPTION	QTY
1	APOLLO FL FLUSH STAINLESS STEEL BEVELLED LID	1
2	APOLLO FL SS 120MM UNDERCARRIAGE	1

Floorbox cut out dimensions: 210mm X 210mm

Floorbox: Apollo FL Flush Stainless Steel Series

PART NO: FLF3080SS

CMS Apollo FL Flush Stainless Steel Floorbox - 3 Compartment, 80mm deep

TECHNICAL SPECIFICATIONS:

CMS 3 compartment , 80mm deep Apollo floorbox flush mount bevelled lid is manufactured from 5mm stainless steel and is suitable in applications requiring additional strength and easily installed into a concrete or timber floor. Accessory boxes come in galvanised steel. The chassis and mounting plates are constructed from powder coated sheet steel with multiple knockouts for conduit. **Load Capacity: 150kg**

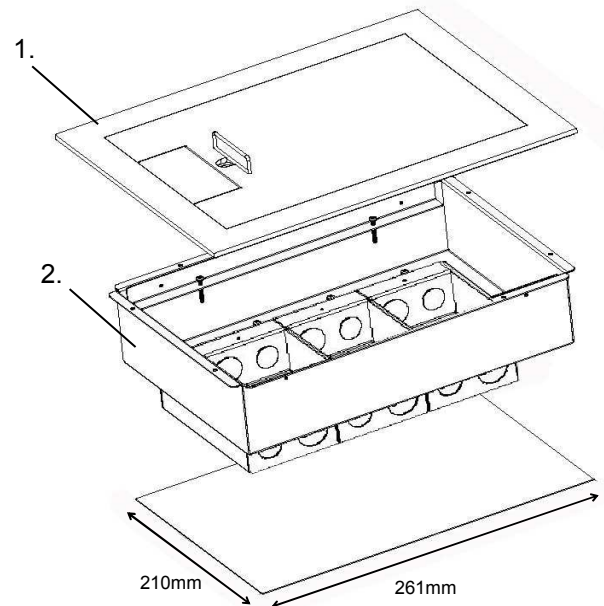
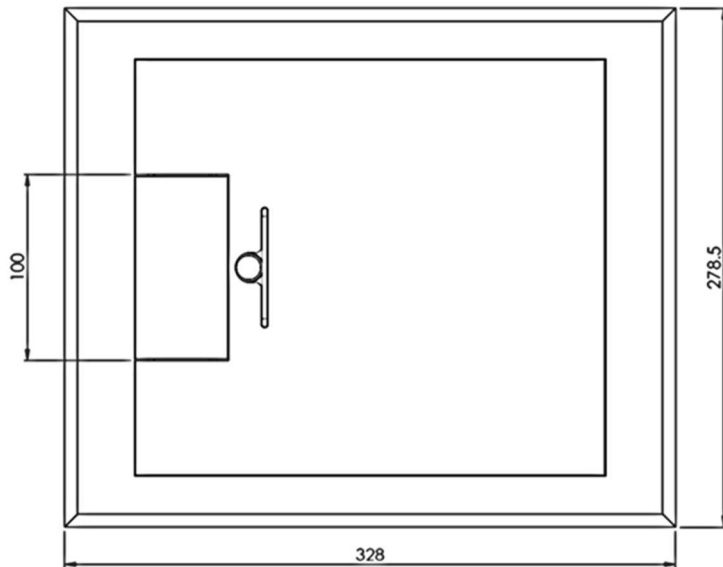
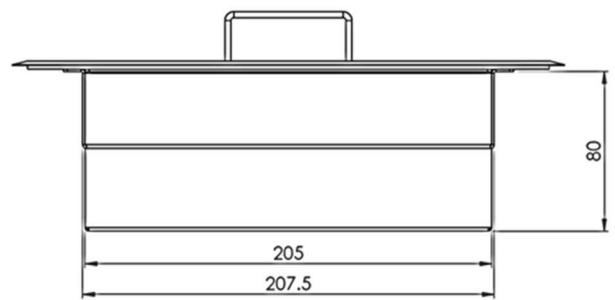
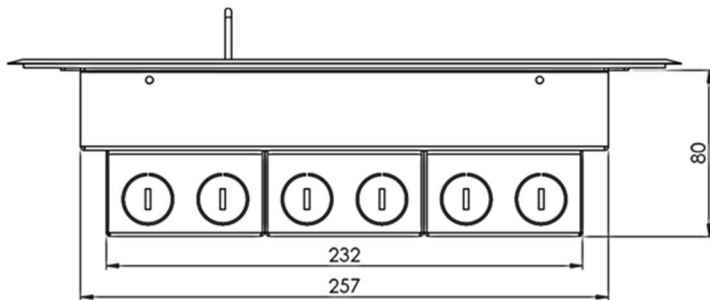

ITEM NO.	DESCRIPTION	QTY
1	APOLLO FL FLUSH STAINLESS STEEL BEVELLED LID	1
2	APOLLO FL SS 80MM UNDERCARRIAGE	1
Floorbox cut out dimensions: 261mm X 210mm		

Floorbox: Apollo FL Flush Stainless Steel Series

PART NO: FLF3090SS

CMS Apollo FL Flush Stainless Steel Floorbox - 3 Compartment, 90mm deep

TECHNICAL SPECIFICATIONS:

CMS 3 compartment , 90mm deep Apollo floorbox flush mount bevelled lid is manufactured from 5mm stainless steel and is suitable in applications requiring additional strength and easily installed into a concrete or timber floor. Accessory boxes come in galvanised steel. The chassis and mounting plates are constructed from powder coated sheet steel with multiple knockouts for conduit. **Load Capacity: 150kg**

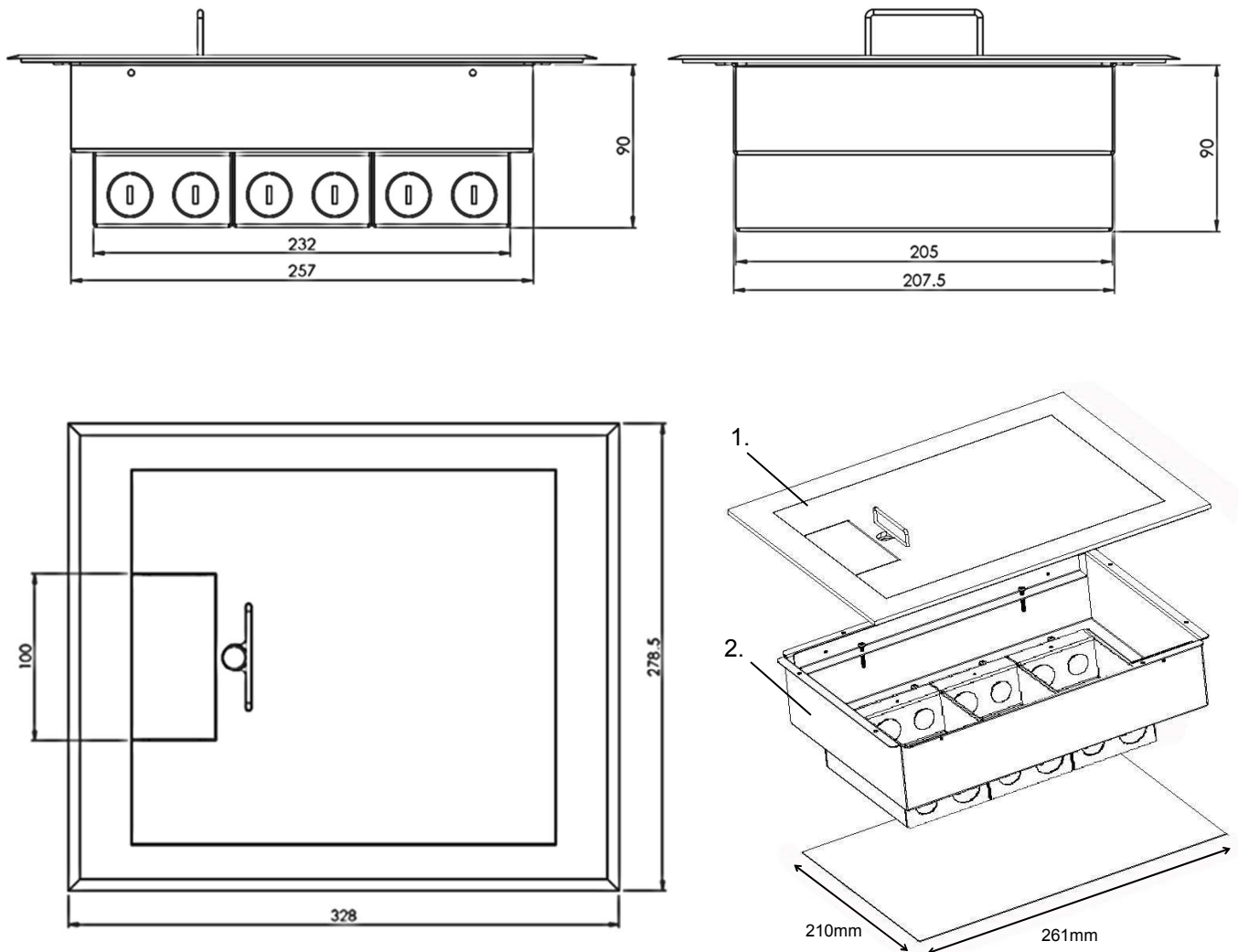

ITEM NO.	DESCRIPTION	QTY
1	APOLLO FL FLUSH STAINLESS STEEL BEVELLED LID	1
2	APOLLO FL SS 90MM UNDERCARRIAGE	1
Floorbox cut out dimensions: 261mm X 210mm		

Floorbox: Apollo FL Flush Stainless Steel Series

PART NO: FLF3120SS

CMS Apollo FL Flush Stainless Steel Floorbox - 3 Compartment, 120mm deep

TECHNICAL SPECIFICATIONS:

CMS 3 compartment , 120mm deep Apollo floorbox flush mount bevelled lid is manufactured from 5mm stainless steel and is suitable in applications requiring additional strength and easily installed into a concrete or timber floor. Accessory boxes come in galvanised steel. The chassis and mounting plates are constructed from powder coated sheet steel with multiple knockouts for conduit. **Load Capacity: 150kg**

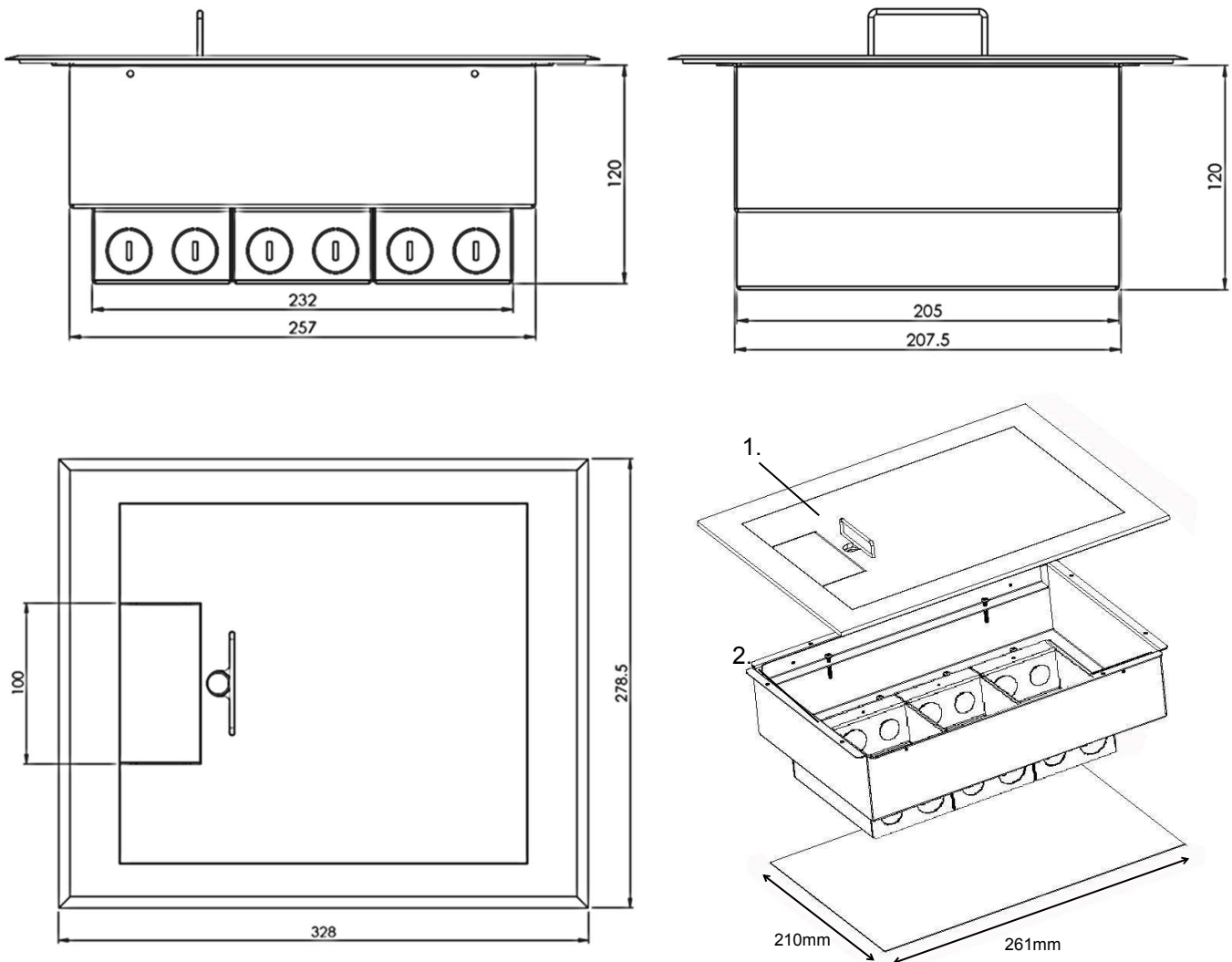

ITEM NO.	DESCRIPTION	QTY
1	APOLLO FL FLUSH STAINLESS STEEL BEVELLED LID	1
2	APOLLO FL SS 120MM UNDERCARRIAGE	1

Floorbox cut out dimensions: 261mm X 210mm

Floorbox: Apollo FL Flush Stainless Steel Series

PART NO: FLF4080SS

CMS Apollo FL Flush Stainless Steel Floorbox - 4 Compartment, 80mm deep

TECHNICAL SPECIFICATIONS:

CMS 4 compartment , 80mm deep Apollo floorbox flush mount bevelled lid is manufactured from 5mm stainless steel and is suitable in applications requiring additional strength and easily installed into a concrete or timber floor. Accessory boxes come in galvanised steel. The chassis and mounting plates are constructed from powder coated sheet steel with multiple knockouts for conduit. **Load Capacity: 150kg**

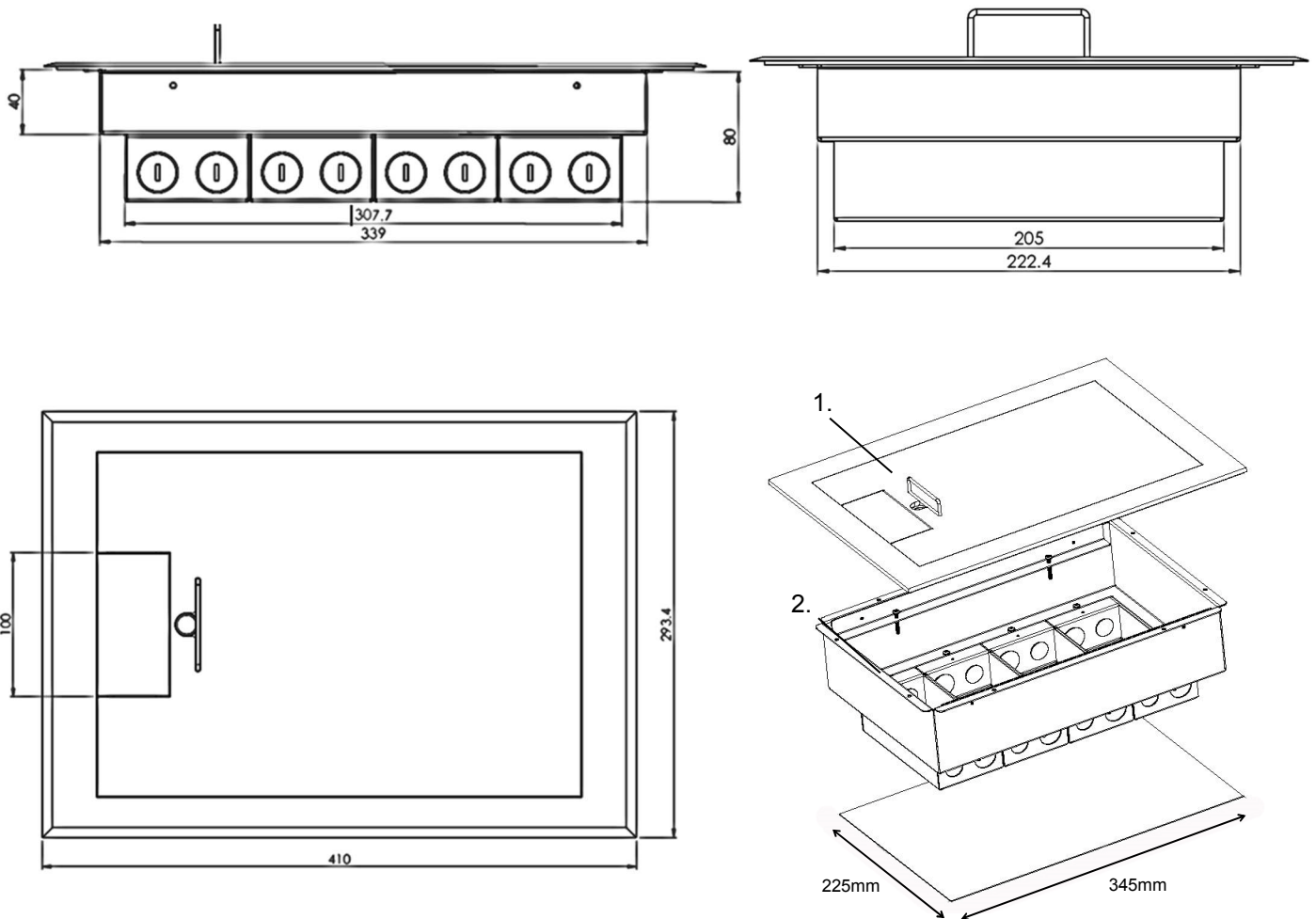

ITEM NO.	DESCRIPTION	QTY
1	APOLLO FL FLUSH STAINLESS STEEL BEVELLED LID	1
2	APOLLO FL SS 80MM UNDERCARRIAGE	1
Floorbox cut out dimensions: 345mm x 225mm		

Floorbox: Apollo FL Flush Stainless Steel Series

PART NO: FLF4090SS

CMS Apollo FL Flush Stainless Steel Floorbox - 4 Compartment, 90mm deep

TECHNICAL SPECIFICATIONS:

CMS 4 compartment , 90mm deep Apollo floorbox flush mount bevelled lid is manufactured from 5mm stainless steel and is suitable in applications requiring additional strength and easily installed into a concrete or timber floor. Accessory boxes come in galvanised steel. The chassis and mounting plates are constructed from powder coated sheet steel with multiple knockouts for conduit. **Load Capacity: 150kg**

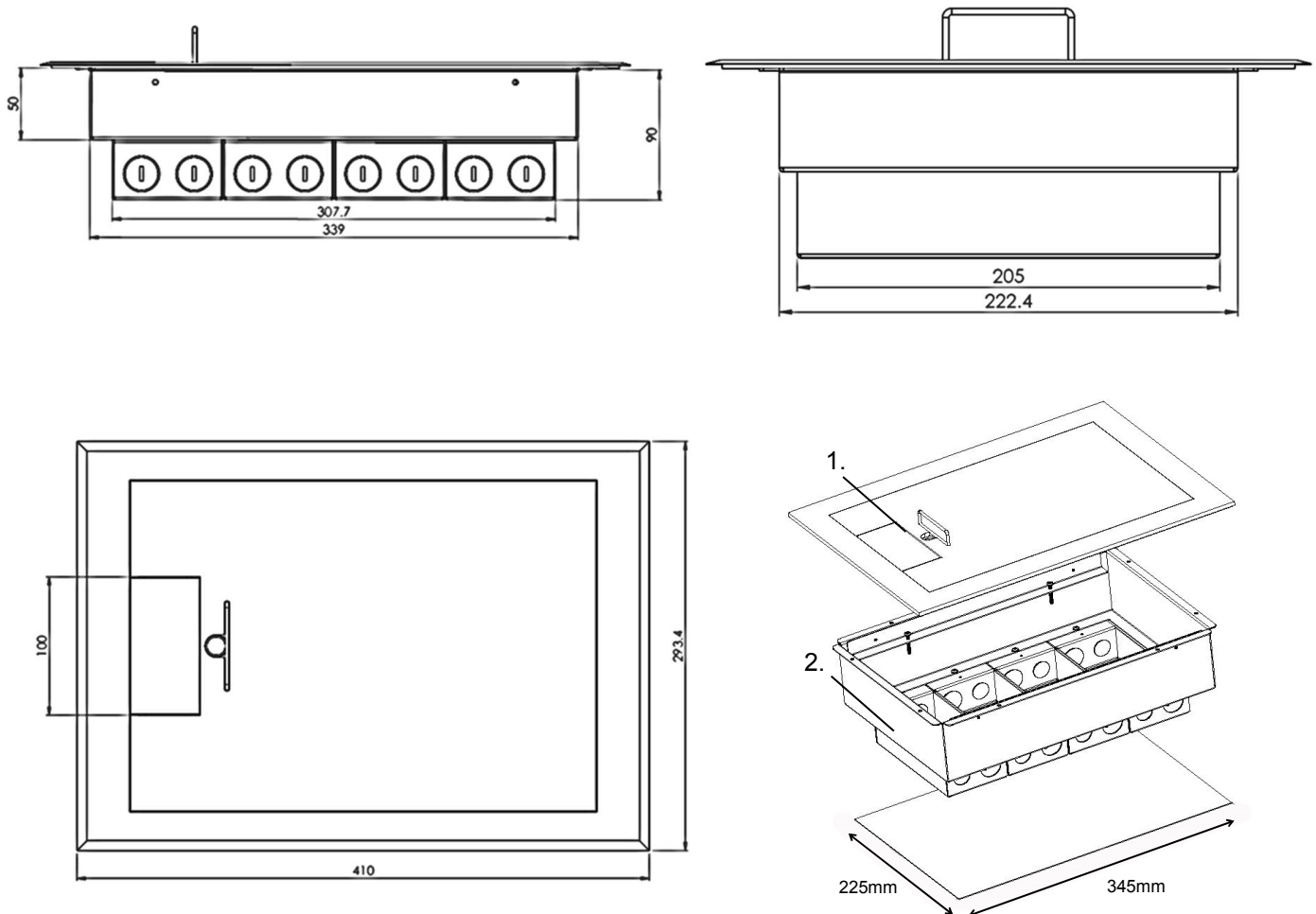

ITEM NO.	DESCRIPTION	QTY
1	APOLLO FL FLUSH STAINLESS STEEL BEVELLED LID	1
2	APOLLO FL SS 90MM UNDERCARRIAGE	1
Floorbox cut out dimensions: 345mm x 225mm		

Floorbox: Apollo FL Flush Stainless Steel Series

PART NO: FLF4120SS

CMS Apollo FL Flush Stainless Steel Floorbox - 4 Compartment, 120mm deep

TECHNICAL SPECIFICATIONS:

CMS 4 compartment , 120mm deep Apollo floorbox flush mount bevelled lid is manufactured from 5mm stainless steel and is suitable in applications requiring additional strength and easily installed into a concrete or timber floor. Accessory boxes come in galvanised steel. The chassis and mounting plates are constructed from powder coated sheet steel with multiple knockouts for conduit. **Load Capacity: 150kg**

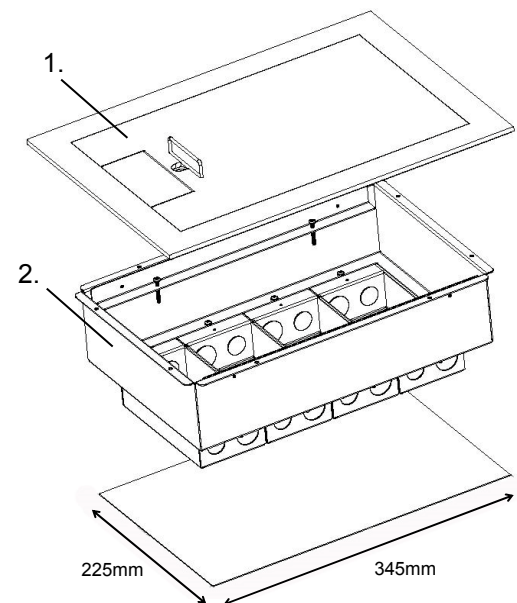
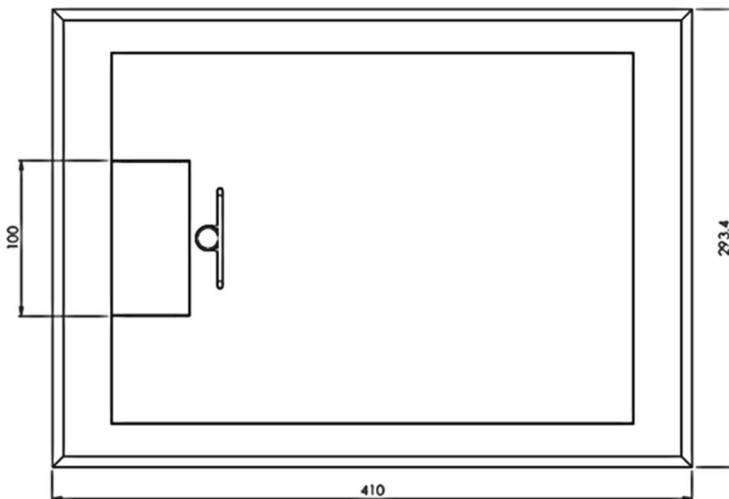
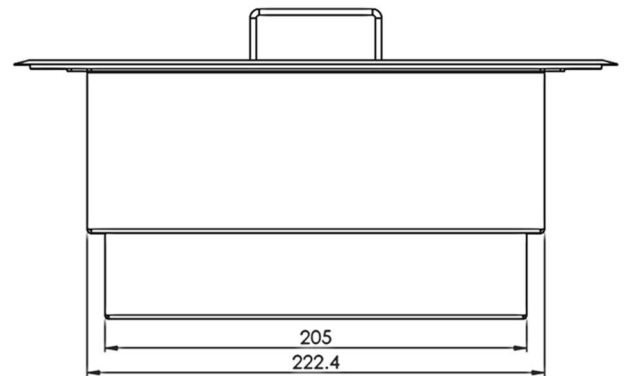
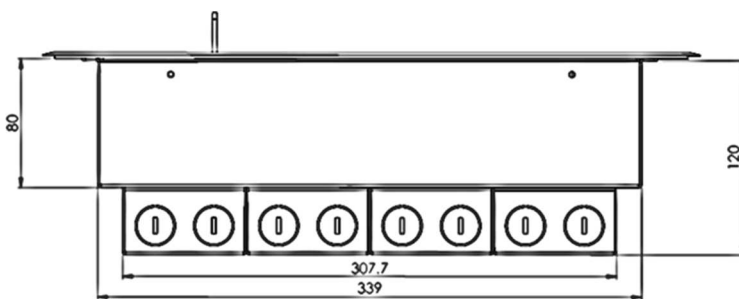

ITEM NO.	DESCRIPTION	QTY
1	APOLLO FL FLUSH STAINLESS STEEL BEVELLED LID	1
2	APOLLO FL SS 120MM UNDERCARRIAGE	1
Floorbox cut out dimensions: 345mm x 225mm		

Floorbox: Apollo FL Recessed Series

PART NO: FL2080

CMS Apollo FL Module Floorbox - 2 Compartment, 80mm deep

TECHNICAL SPECIFICATIONS:

CMS 2 Compartment, 80mm deep Apollo FL floorbox with multi directional, high-impact Polycarbonate lid & easy to grab lifting handle. The chassis and mounting plates are constructed from powder coated sheet steel with multiple cable entry points. Accessories boxes are made in galvanised steel. Lid available in Grey or Black. **Load Capacity: 120kg**

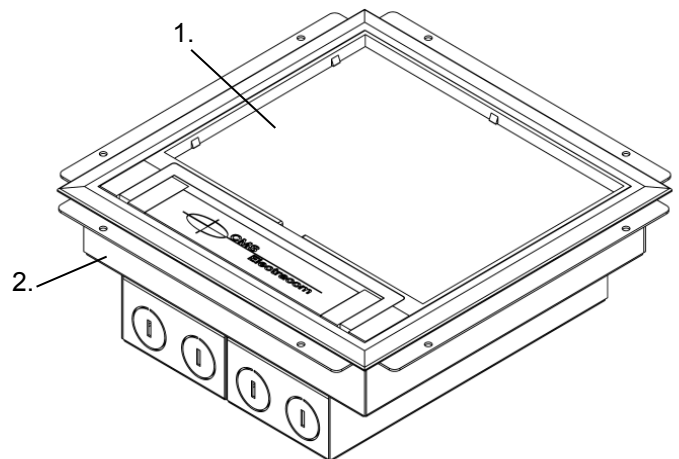
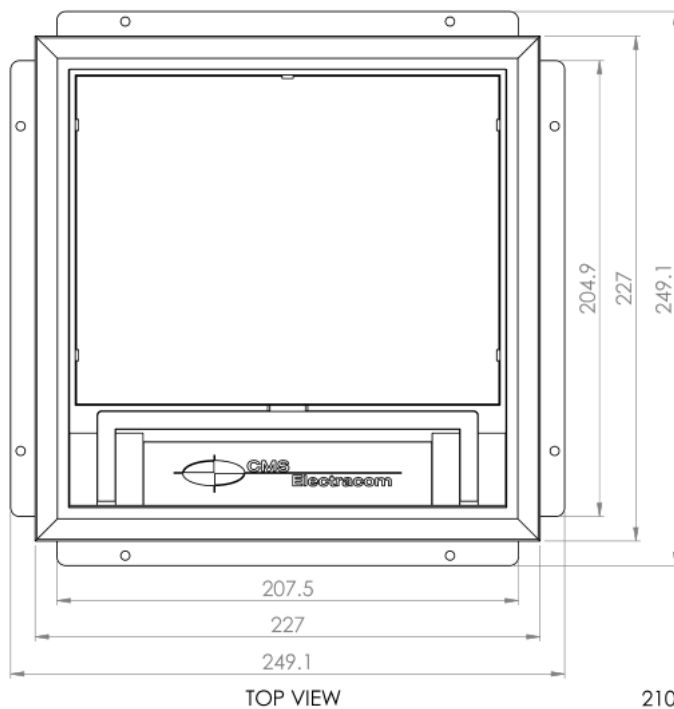
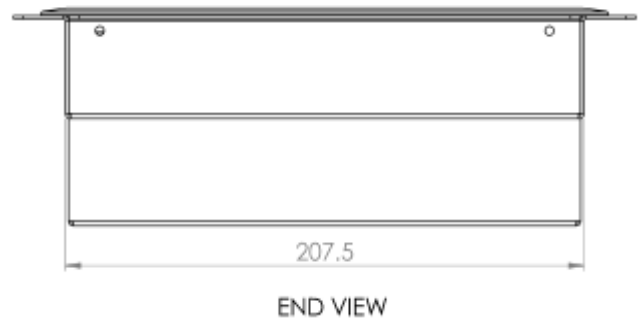
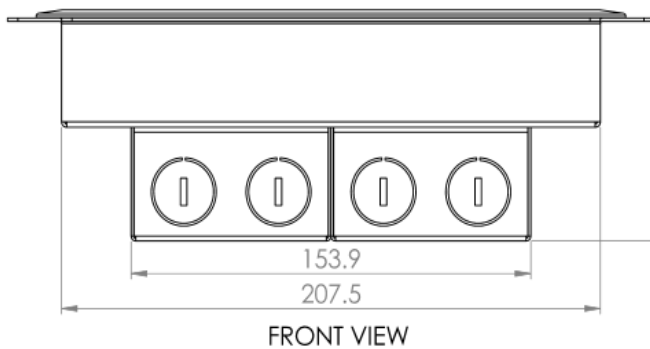

ITEM NO.	DESCRIPTION	QTY
1	APOLLO FL LID	1
2	APOLLO FL 80MM UNDERCARRIAGE	1

Floorbox cut out dimensions: 210mm x 210m

Floorbox: Apollo FL Recessed Series

PART NO: FL2090

CMS Apollo FL Module Floorbox - 2 Compartment, 90mm deep

TECHNICAL SPECIFICATIONS:

CMS 2 Compartment, 90mm deep Apollo FL floorbox with multi directional, high-impact Polycarbonate lid & easy to grab lifting handle. The chassis and mounting plates are constructed from powder coated sheet steel with multiple cable entry points. Accessories boxes are made in galvanised steel. Lid available in Grey or Black. **Load Capacity: 120kg**

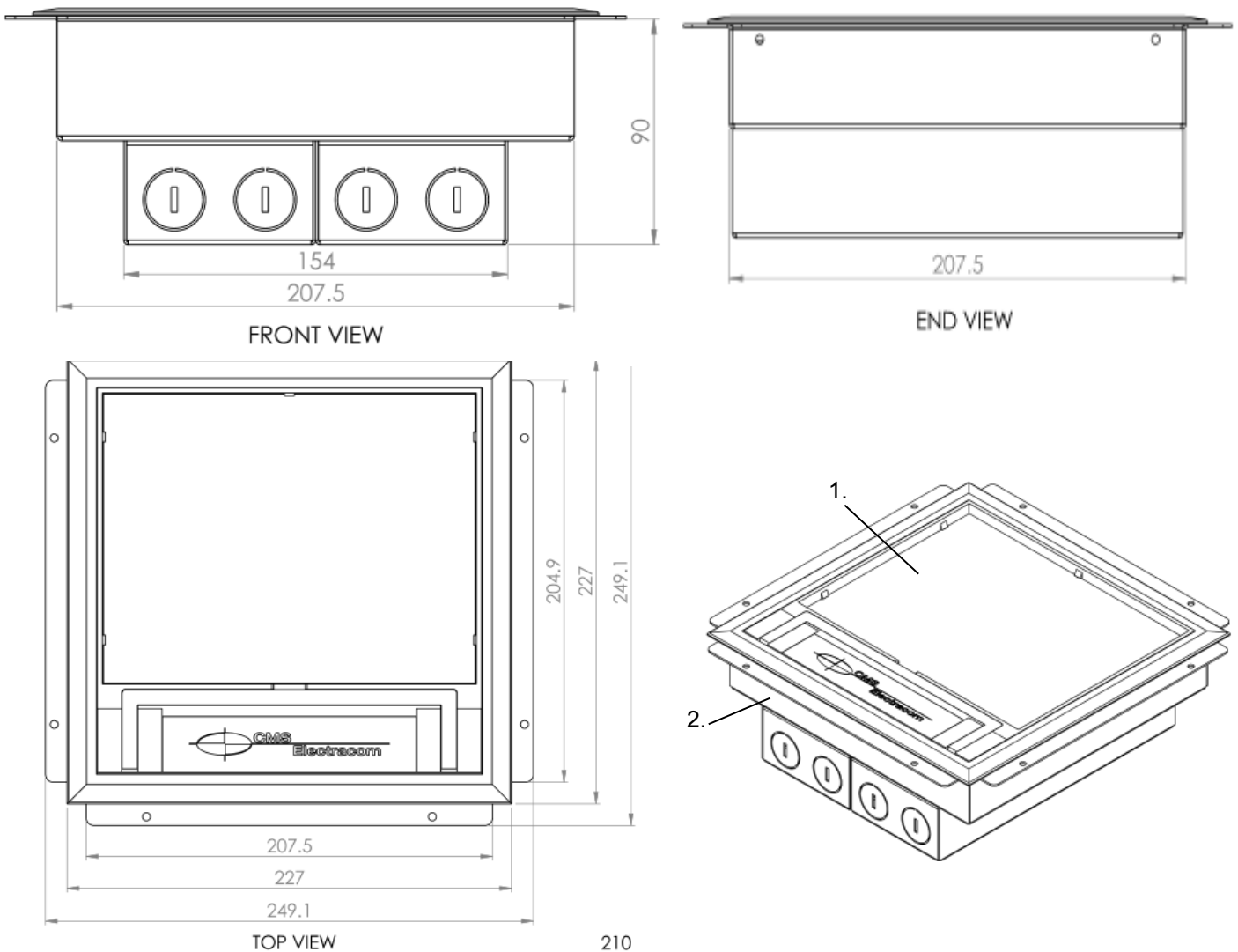

ITEM NO.	DESCRIPTION	QTY
1	APOLLO FL LID	1
2	APOLLO FL 90MM UNDERCARRIAGE	1
Floorbox cut out dimensions: 210mm x 210m		

Floorbox: Apollo FL Recessed Series

PART NO: FL2120

CMS Apollo FL Module Floorbox - 2 Compartment, 120mm deep

TECHNICAL SPECIFICATIONS:

CMS 2 Compartment, 120mm deep Apollo FL floorbox with multi directional, high-impact Polycarbonate lid & easy to grab lifting handle. The chassis and mounting plates are constructed from powder coated sheet steel with multiple cable entry points. Accessories boxes are made in galvanised steel. Lid available in Grey or Black. **Load Capacity: 120kg**

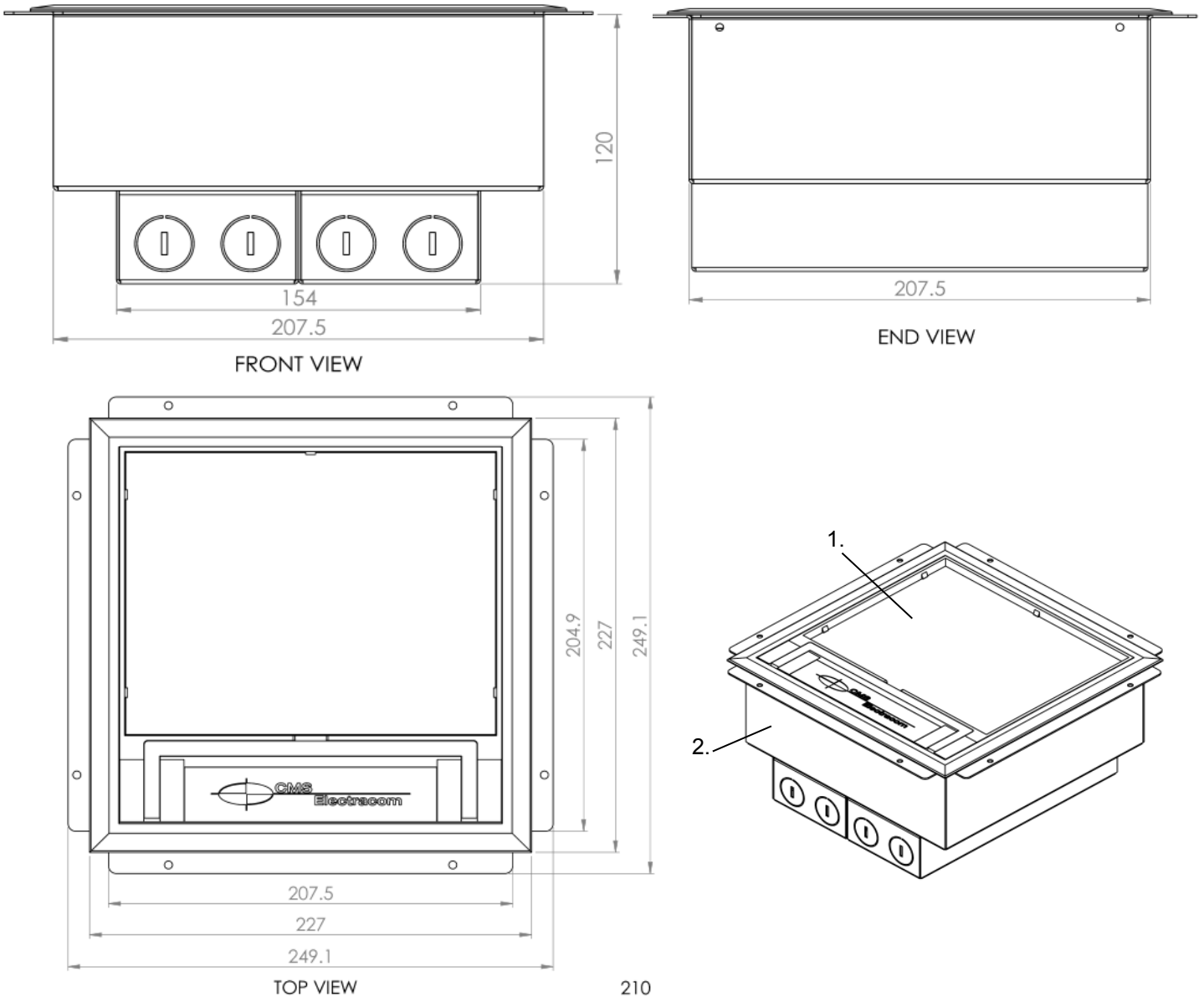

ITEM NO.	DESCRIPTION	QTY
1	APOLLO FL LID	1
2	APOLLO FL 120MM UNDERCARRIAGE	1
Floorbox cut out dimensions: 210mm x 210m		

Floorbox: Apollo FL Recessed Series

PART NO: FL3080

CMS Apollo FL3 Module Floorbox - 3 Compartment, 80mm deep

TECHNICAL SPECIFICATIONS:

CMS 3 Compartment, 80mm deep Apollo FL floorbox with multi directional, high-impact Polycarbonate lid & easy to grab lifting handle. The chassis and mounting plates are constructed from powder coated sheet steel with multiple cable entry points. Accessories boxes are made in galvanised steel. Lid available in Grey or Black. **Load Capacity: 120kg**

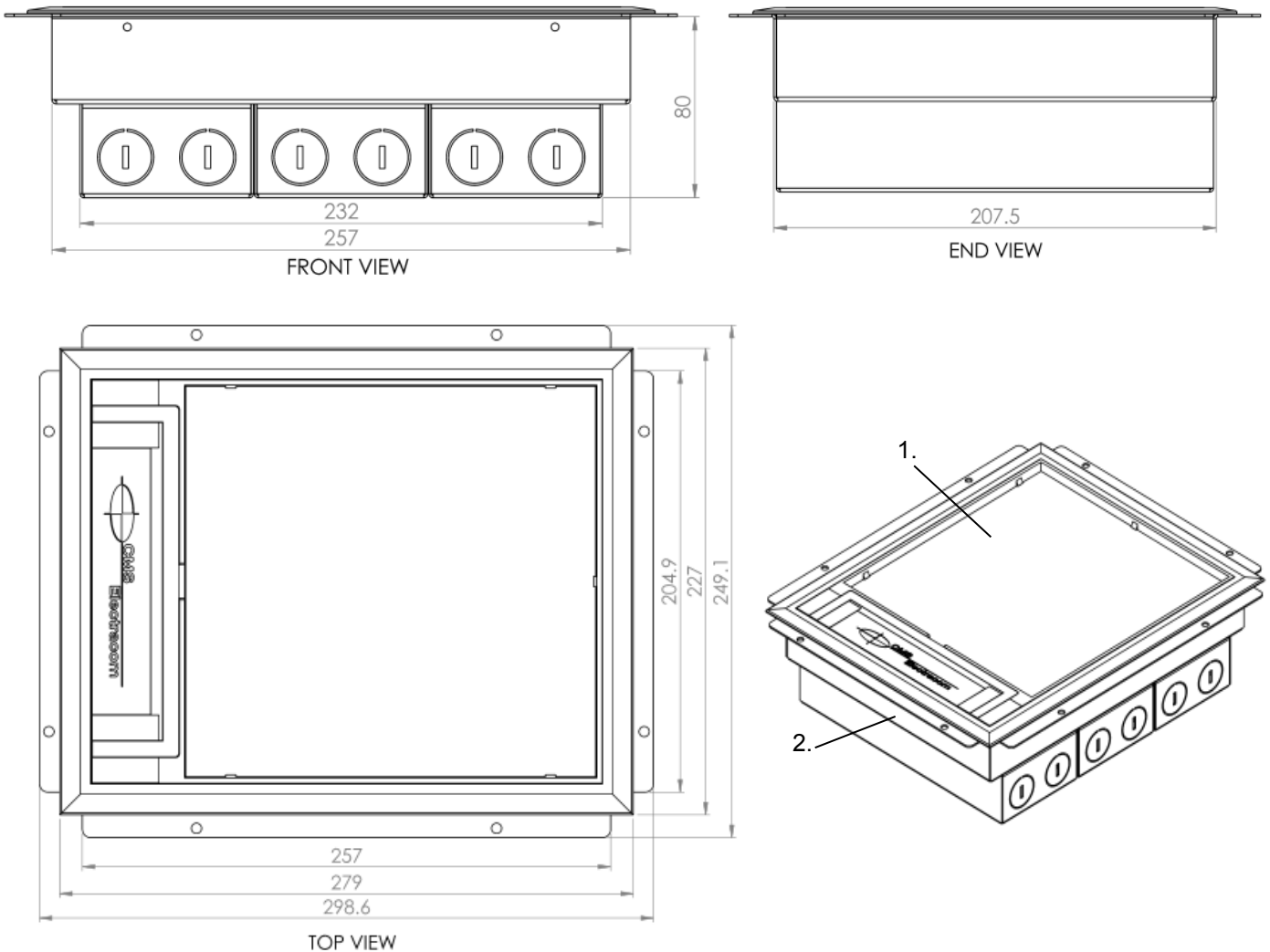

ITEM NO.	DESCRIPTION	QTY
1	APOLLO FL LID	1
2	APOLLO FL3 80MM UNDERCARRIAGE	1

Floorbox cut out dimensions: 261mm x 210mm

Floorbox: Apollo FL Recessed Series

PART NO: FL3090

CMS Apollo FL3 Module Floorbox - 3 Compartment, 90mm deep

TECHNICAL SPECIFICATIONS:

CMS 3 Compartment, 90mm deep Apollo FL floorbox with multi directional, high-impact Polycarbonate lid & easy to grab lifting handle. The chassis and mounting plates are constructed from powder coated sheet steel with multiple cable entry points. Accessories boxes are made in galvanised steel. Lid available in Grey or Black. **Load Capacity: 120kg**

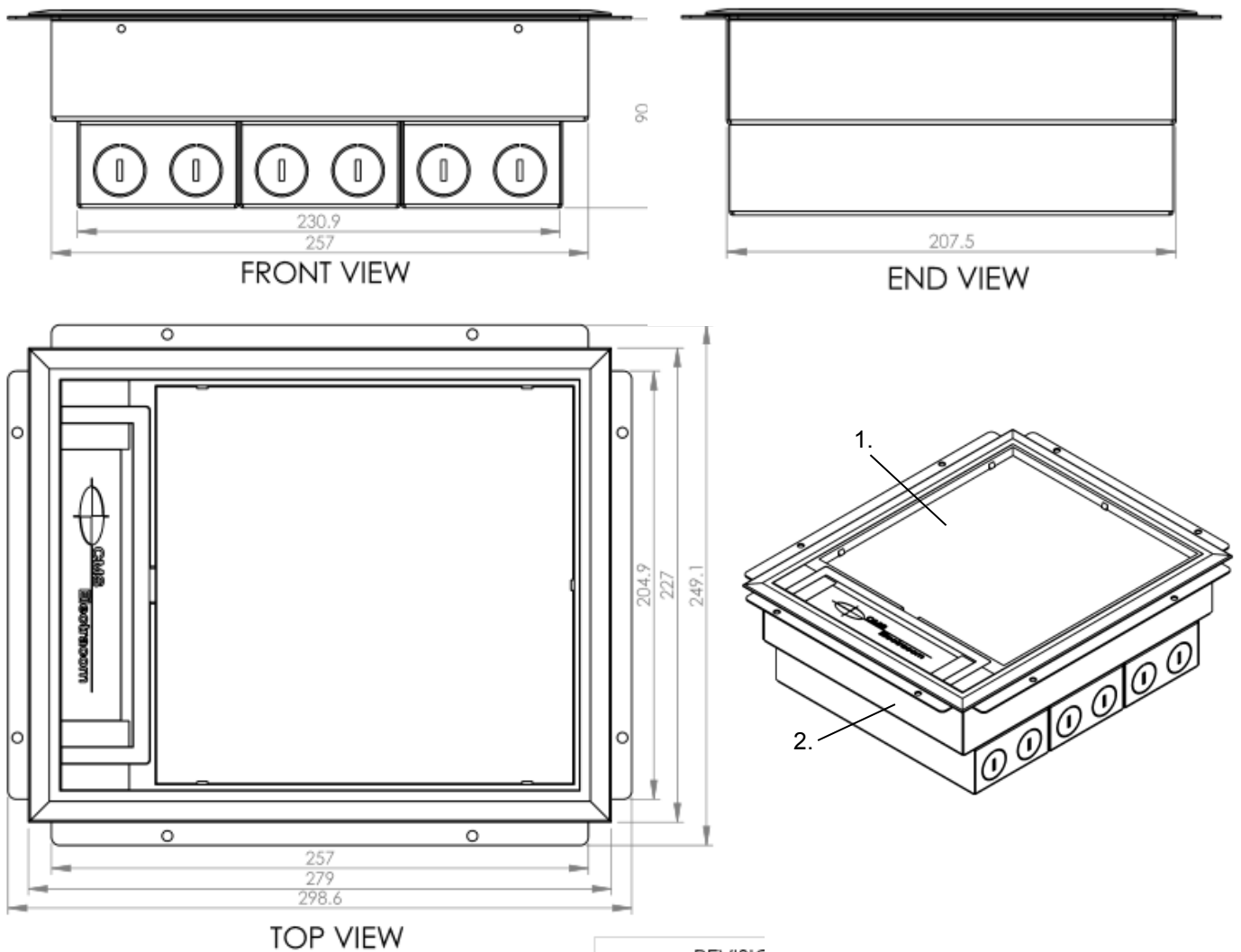

ITEM NO.	DESCRIPTION	QTY
1	APOLLO FL LID	1
2	APOLLO FL3 90MM UNDERCARRIAGE	1
Floorbox cut out dimensions: 261mm x 210mm		

Floorbox: Apollo FL Recessed Series

PART NO: FL3120

CMS Apollo FL3 Module Floorbox - 3 Compartment, 120mm deep

TECHNICAL SPECIFICATIONS:

CMS 3 Compartment, 120mm deep Apollo FL floorbox with multi directional, high-impact Polycarbonate lid & easy to grab lifting handle. The chassis and mounting plates are constructed from powder coated sheet steel with multiple cable entry points. Accessories boxes are made in galvanised steel. Lid available in Grey or Black. **Load Capacity: 120kg**

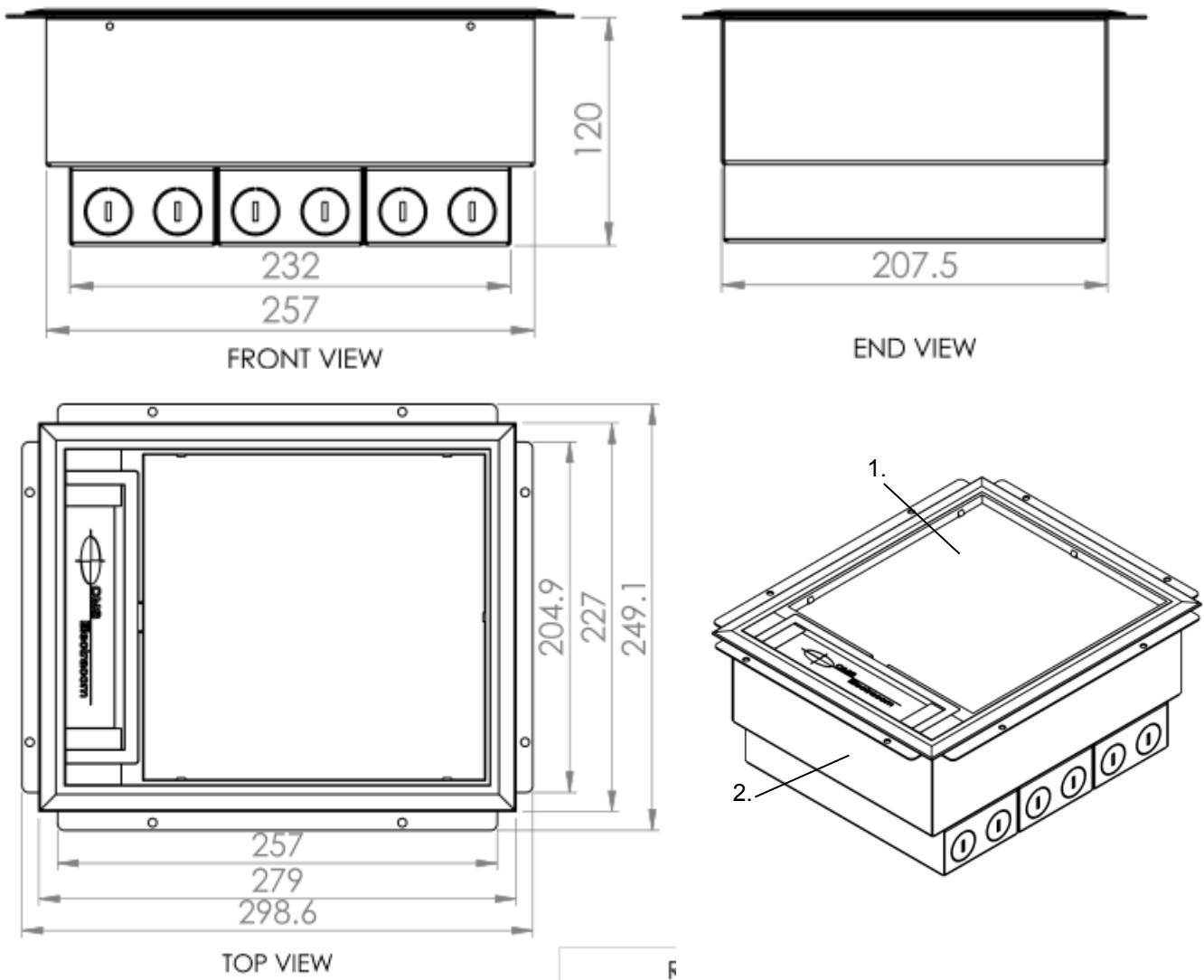

ITEM NO.	DESCRIPTION	QTY
1	APOLLO FL LID	1
2	APOLLO FL3 120MM UNDERCARRIAGE	1
Floorbox cut out dimensions: 261mm x 210mm		

Floorbox: Apollo FL Recessed Series

PART NO: FL4080

CMS Apollo FL4 Module Floorbox - 4 Compartment, 80mm deep

TECHNICAL SPECIFICATIONS:

CMS 4 Compartment, 80mm deep Apollo FL floorbox with multi directional, high-impact Polycarbonate lid & easy to grab lifting handle. The chassis and mounting plates are constructed from powder coated sheet steel with multiple cable entry points. Accessories boxes are made in galvanised steel. Lid available in Grey or Black. **Load Capacity: 120kg**

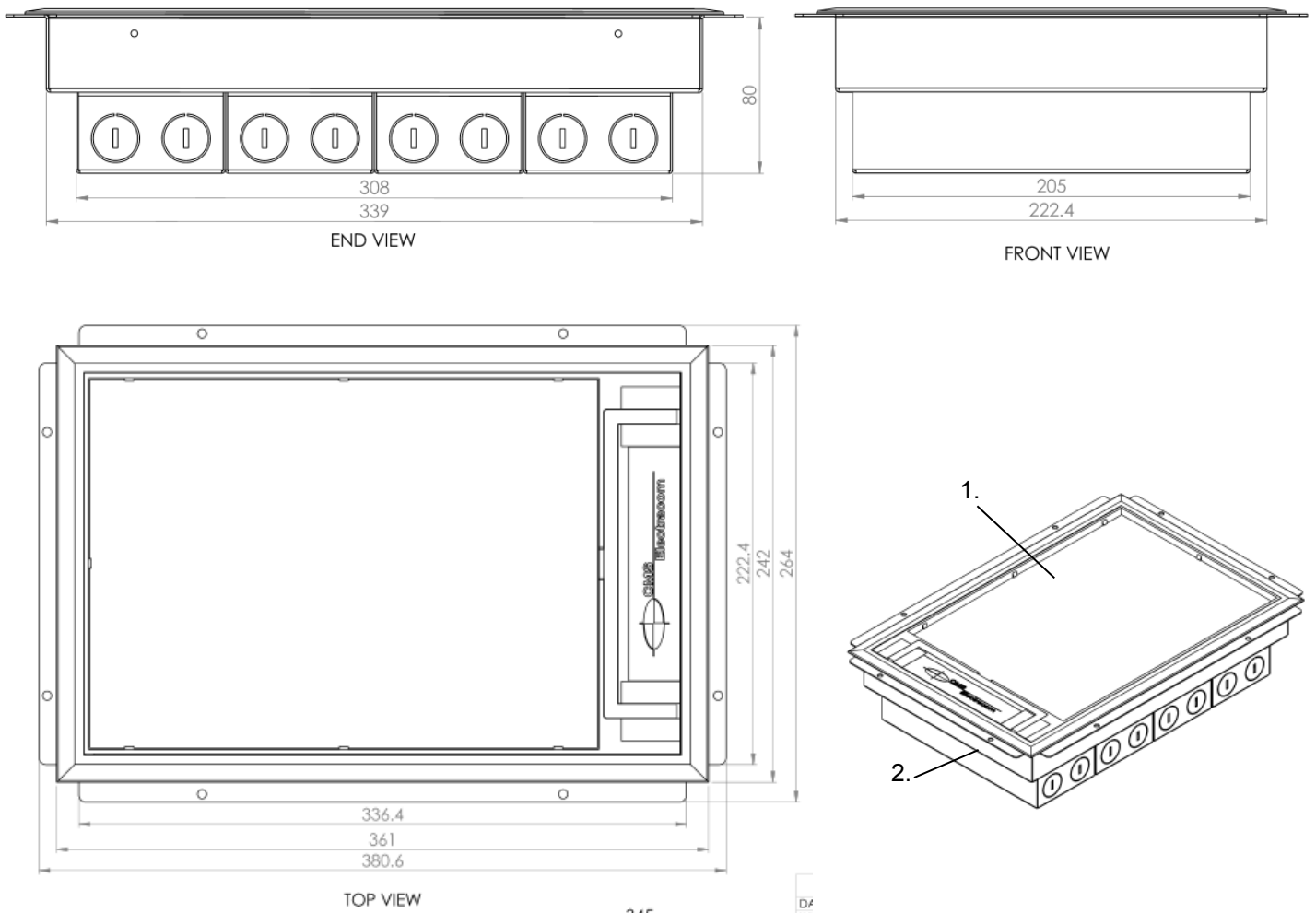

ITEM NO.	DESCRIPTION	QTY
1	APOLLO FL LID	1
2	APOLLO FL4 80MM UNDERCARRIAGE	1
Floorbox cut out dimensions: 345mm x 225mm		

Floorbox: Apollo FL Recessed Series

PART NO: FL4090

CMS Apollo FL4 Module Floorbox - 4 Compartment, 90mm deep

TECHNICAL SPECIFICATIONS:

CMS 4 Compartment, 90mm deep Apollo FL floorbox with multi directional, high-impact Polycarbonate lid & easy to grab lifting handle. The chassis and mounting plates are constructed from powder coated sheet steel with multiple cable entry points. Accessories boxes are made in galvanised steel. Lid available in Grey or Black. **Load Capacity: 120kg**

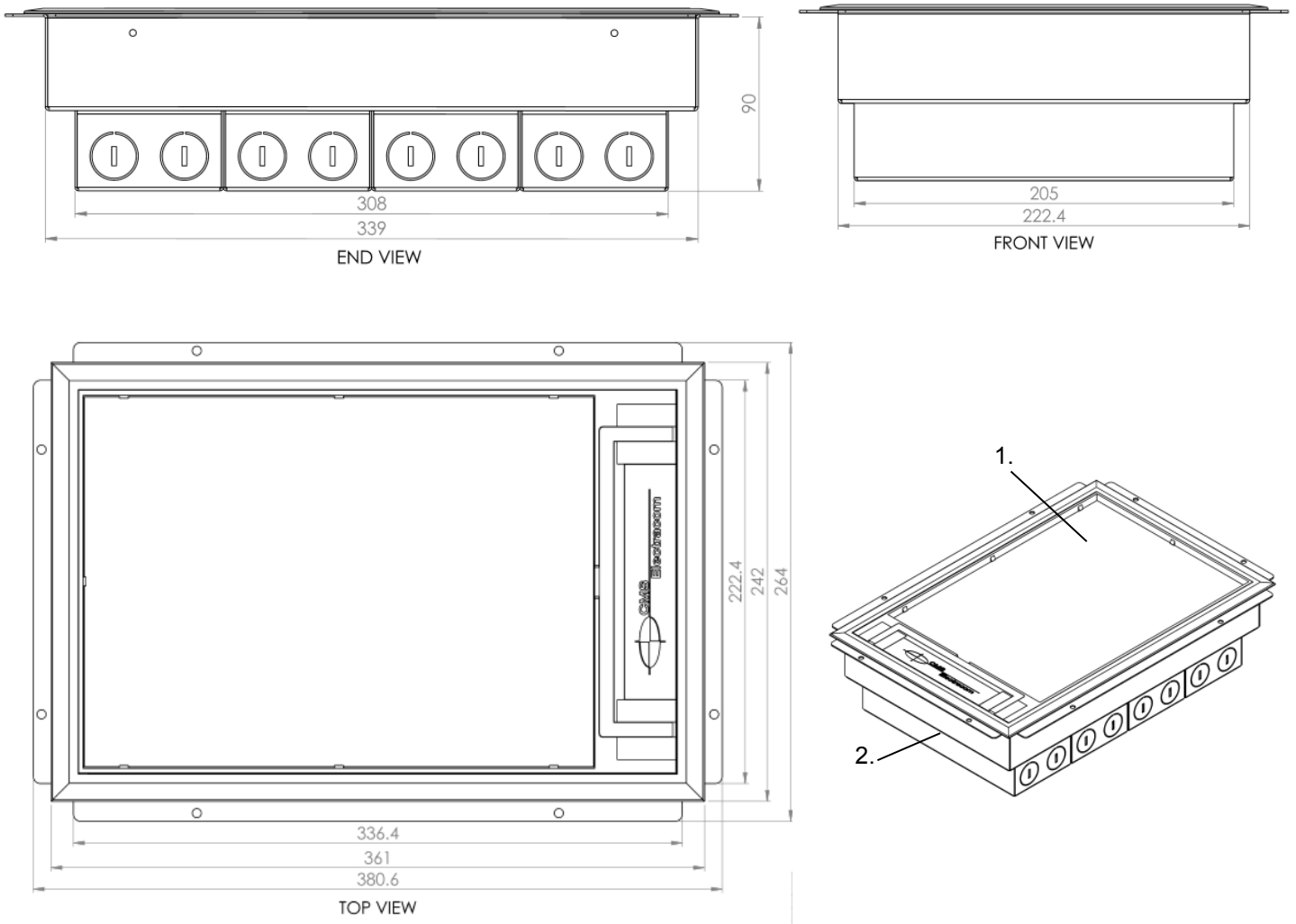

ITEM NO.	DESCRIPTION	QTY
1	APOLLO FL LID LARGE	1
2	APOLLO FL4 90MM LARGE UNDERCARRIAGE	1

Floorbox cut out dimensions: 345mm x 225mm

Floorbox: Apollo FL Recessed Series

PART NO: FL4120

CMS Apollo FL4 Module Floorbox - 4 Compartment, 120mm deep

TECHNICAL SPECIFICATIONS:

CMS 4 Compartment, 120mm deep Apollo FL floorbox with multi directional, high-impact Polycarbonate lid & easy to grab lifting handle. The chassis and mounting plates are constructed from powder coated sheet steel with multiple cable entry points. Accessories boxes are made in galvanised steel. Lid available in Grey or Black. **Load Capacity: 120kg**

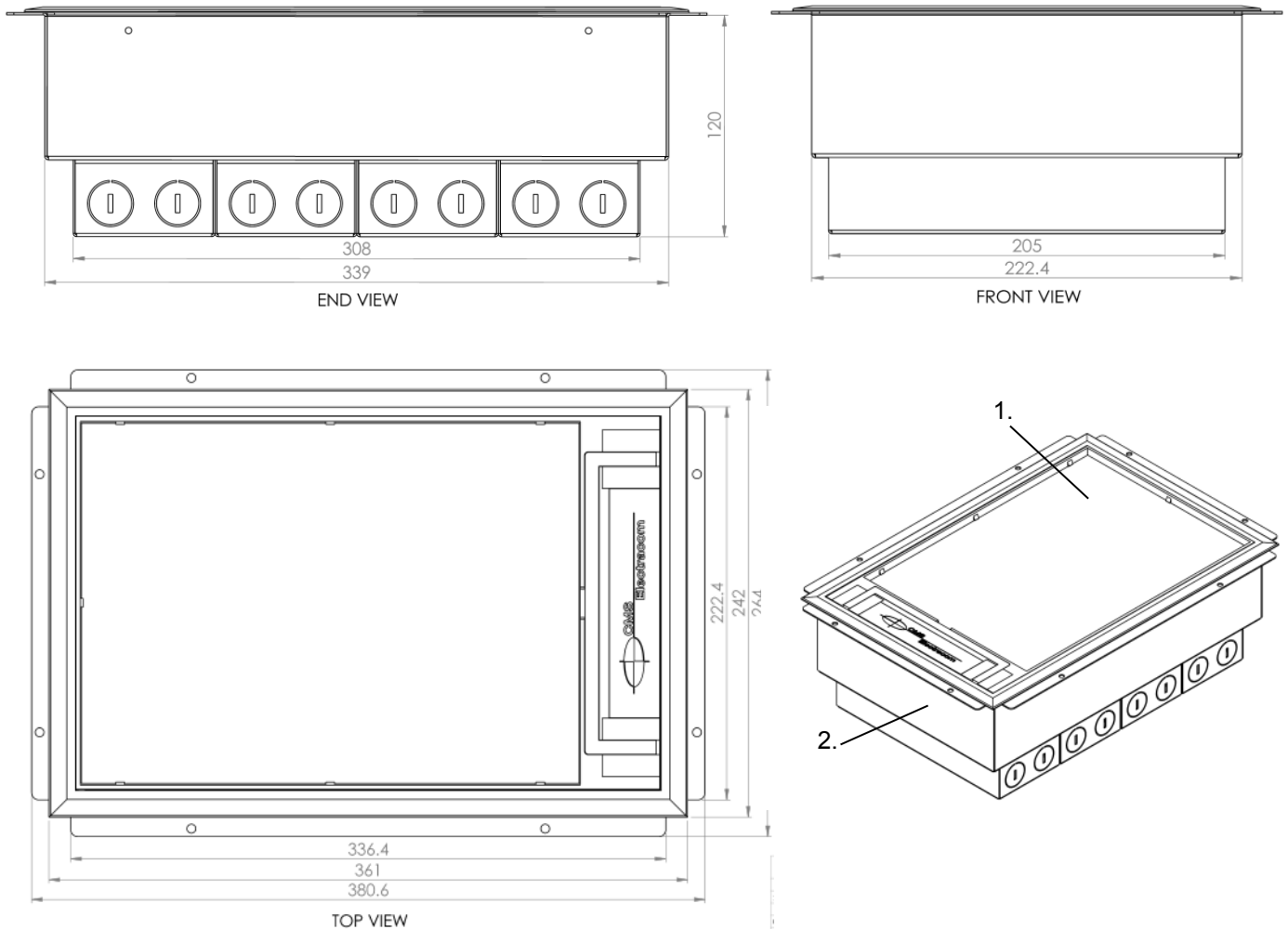

ITEM NO.	DESCRIPTION	QTY
1	APOLLO FL LID LARGE	1
2	APOLLO FL4 120MM LARGE UNDERCARRIAGE	1
Floorbox cut out dimensions: 345mm x 225mm		

Floorbox: Apollo FL Recessed Stainless Steel Series

PART NO: FL2080SS

CMS Apollo FL Stainless Steel Recessed Module Floorbox - 2 Compartment, 80mm deep

TECHNICAL SPECIFICATIONS:

CMS 2 Compartment, 80mm deep Apollo FL SS floorbox with 12mm recessed stainless steel lid,

easy to grab lifting handle and cable exit cap. The chassis and mounting plates are constructed from powder coated sheet steel with multiple cable entry points. **Load Capacity: 150kg**

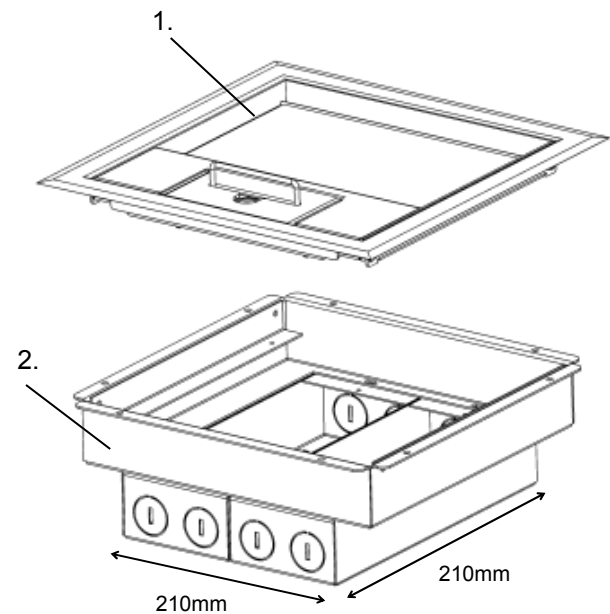
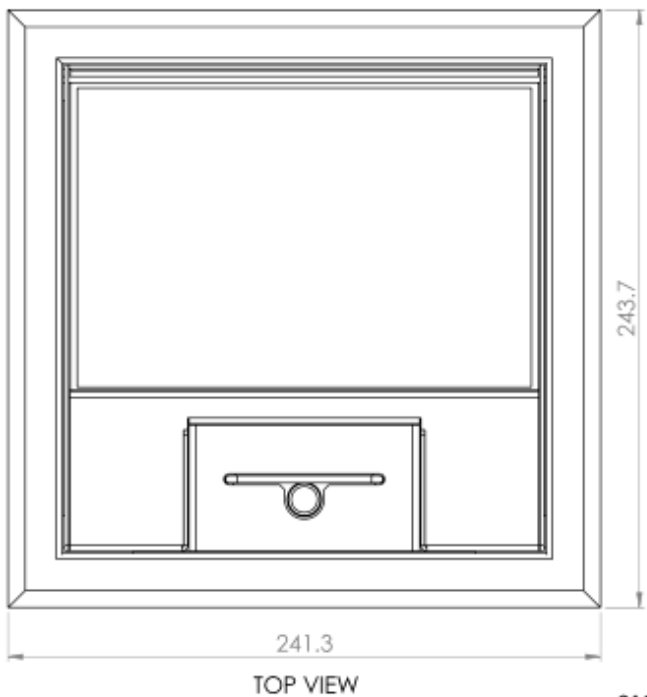
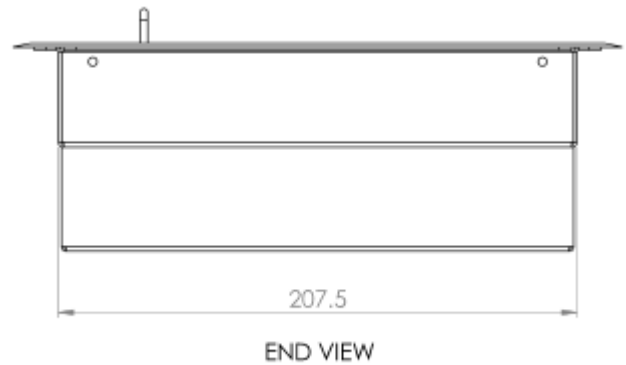
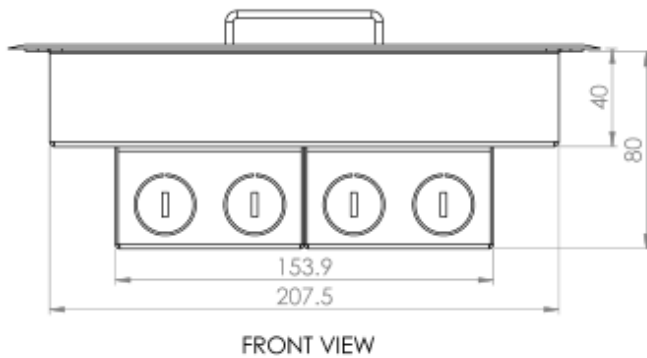

210

ITEM NO.	DESCRIPTION	QTY
1	APOLLO RECESSED STAINLESS STEEL LID	1
2	APOLLO FL SS 80MM UNDERCARRIAGE	1
Floorbox cut out dimensions: 210mm x 210mm		

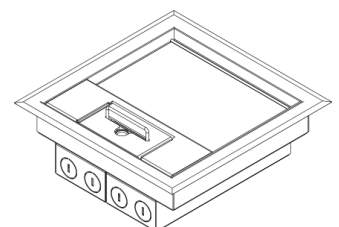

Floorbox: Apollo FL Recessed Stainless Steel Series

PART NO: FL2090SS

CMS Apollo FL Stainless Steel Recessed Module Floorbox - 2 Compartment, 90mm deep

TECHNICAL SPECIFICATIONS:

CMS 2 Compartment, 90mm deep Apollo FL SS floorbox with 12mm recessed stainless steel lid, easy to grab lifting handle and cable exit cap. The chassis and mounting plates are constructed from powder coated sheet steel with multiple cable entry points.

Load Capacity: 150kg

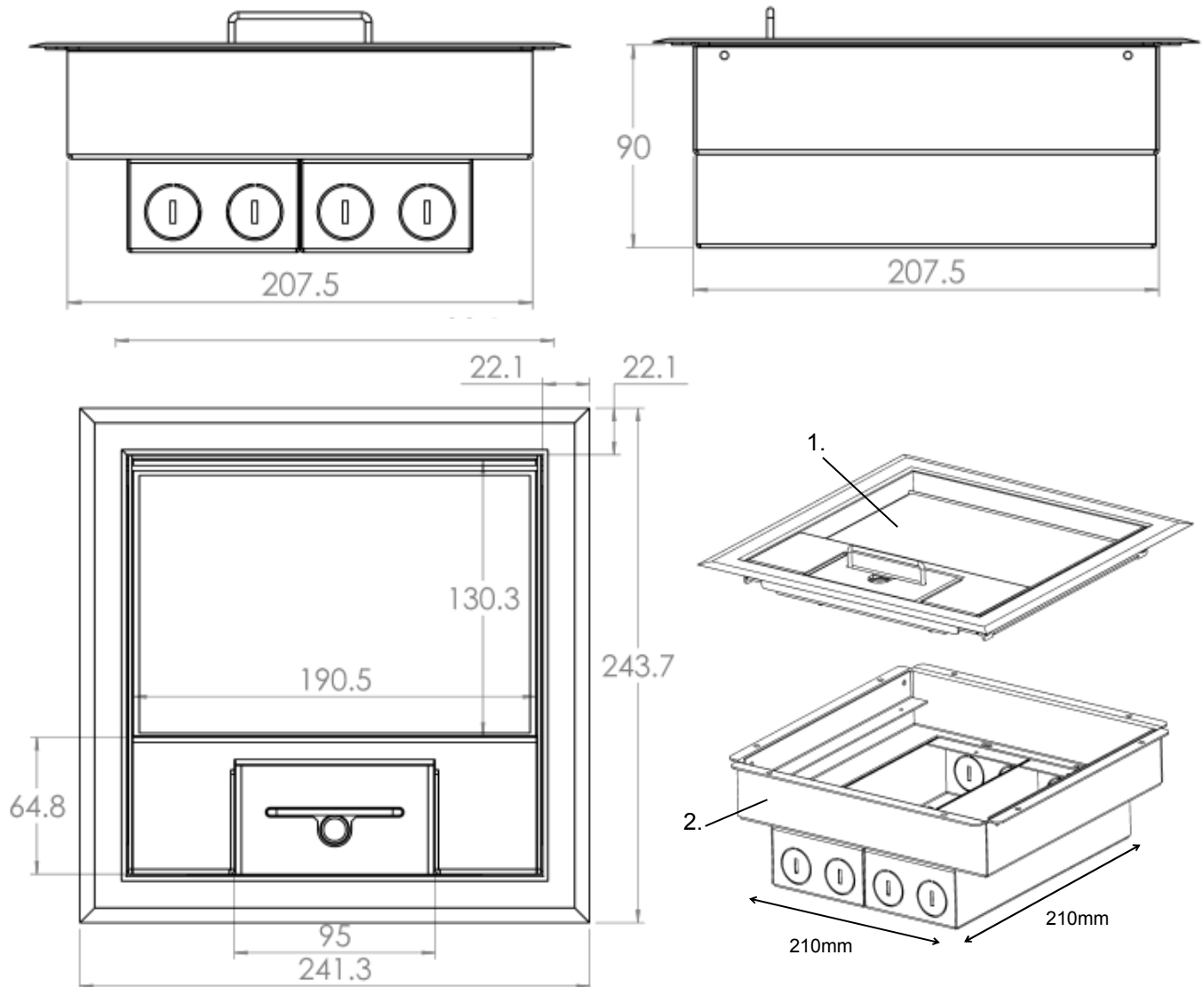

ITEM NO.	DESCRIPTION	QTY
1	APOLLO RECESSED STAINLESS STEEL LID	1
2	APOLLO FL SS 90MM UNDERCARRIAGE	1
Floorbox cut out dimensions: 210mm x 210mm		

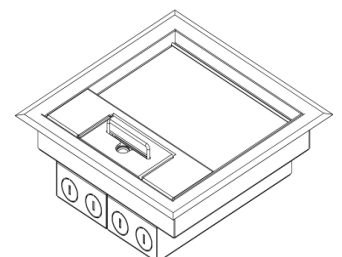

Floorbox: Apollo FL Recessed Stainless Steel Series

PART NO: FL2120SS

CMS Apollo FL Stainless Steel Recessed Module Floorbox - 2 Compartment, 120mm deep

TECHNICAL SPECIFICATIONS:

CMS 2 Compartment, 120mm deep Apollo FL SS floorbox with 12mm recessed stainless steel lid, easy to grab lifting handle and cable exit cap. The chassis and mounting plates are constructed from powder coated sheet steel with multiple cable entry points.

Load Capacity: 150kg

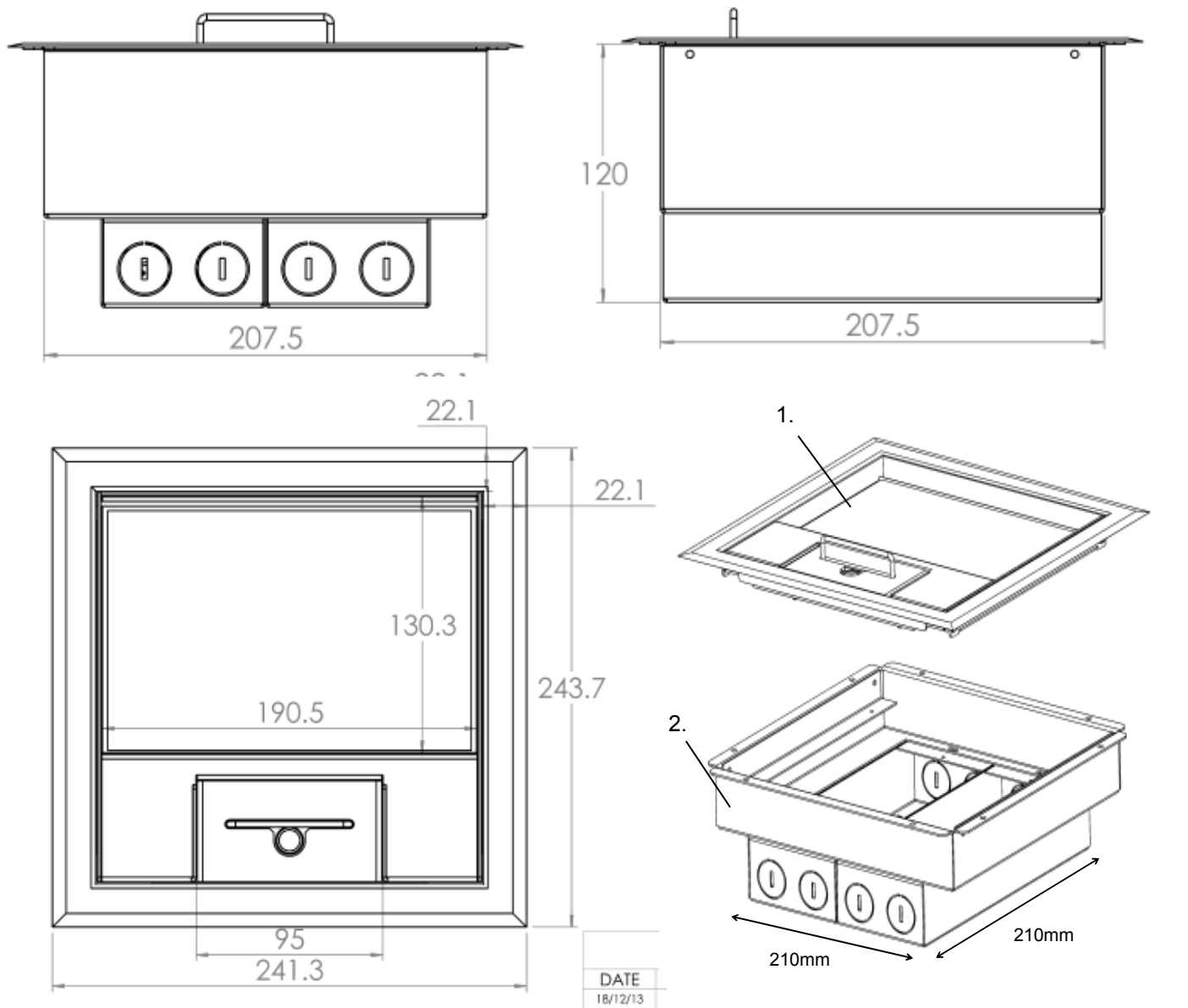

ITEM NO.	DESCRIPTION	QTY
1	APOLLO RECESSED STAINLESS STEEL LID	1
2	APOLLO FL SS 120MM UNDERCARRIAGE	1

Floorbox cut out dimensions: 210mm x 210mm

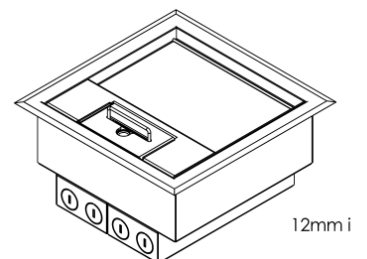

Floorbox: Apollo FL Recessed Stainless Steel Series

PART NO: FL3080SS

CMS Apollo FL Stainless Steel Recessed Module Floorbox - 3 Compartment, 80mm deep

TECHNICAL SPECIFICATIONS:

CMS 3 Compartment, 80mm deep Apollo FL SS floorbox with 12mm recessed stainless steel lid, easy to grab lifting handle and cable exit cap. The chassis and mounting plates are constructed from powder coated sheet steel with multiple cable entry points.

Load Capacity: 150kg

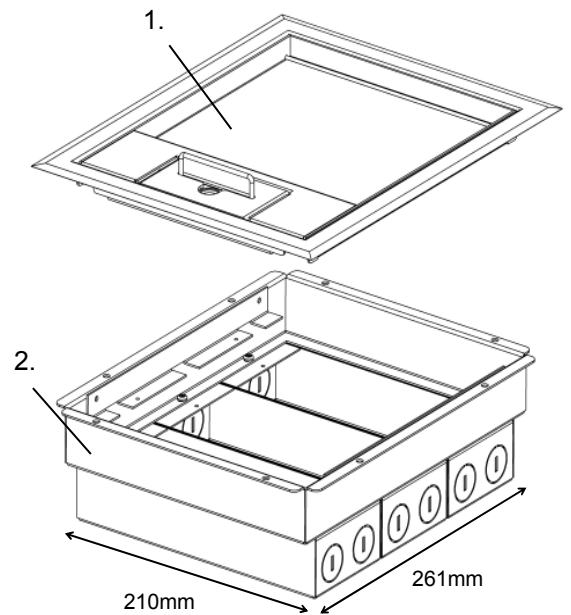
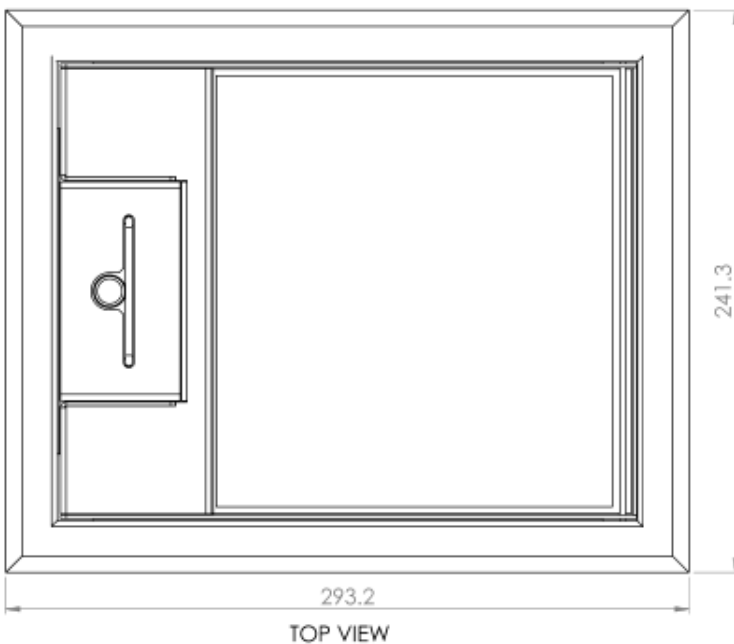
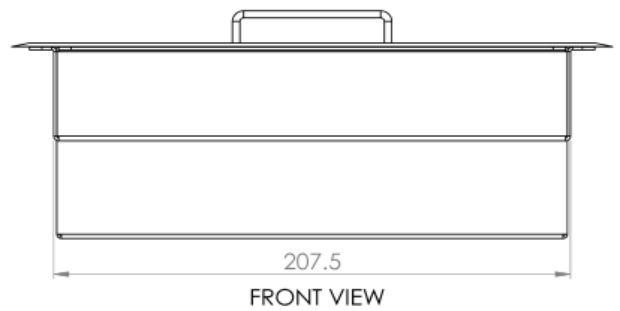
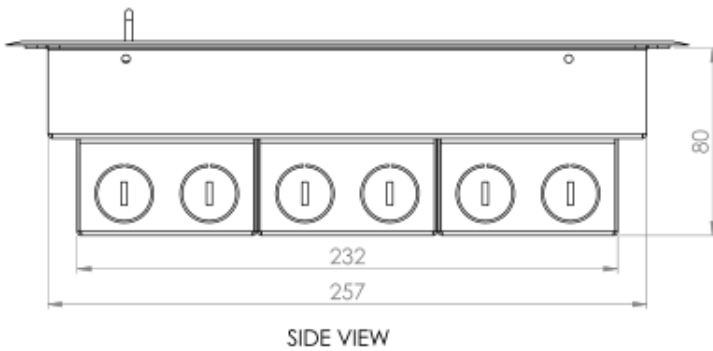

ITEM NO.	DESCRIPTION	QTY
1	APOLLO RECESSED STAINLESS STEEL LID	1
2	APOLLO FL SS 80MM UNDERCARRIAGE	1
Floorbox cut out dimensions: 261mm x 210mm		

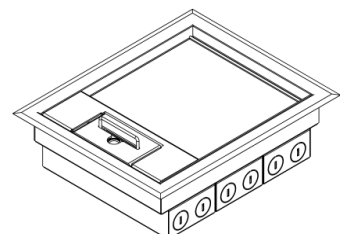

Floorbox: Apollo FL Recessed Stainless Steel Series

PART NO: FL3090SS

CMS Apollo FL Stainless Steel Recessed Module Floorbox - 3 Compartment, 90mm deep

TECHNICAL SPECIFICATIONS:

CMS 3 Compartment, 90mm deep Apollo FL SS floorbox with 12mm recessed stainless steel lid, easy to grab lifting handle and cable exit cap. The chassis and mounting plates are constructed from powder coated sheet steel with multiple cable entry points.

Load Capacity: 150kg

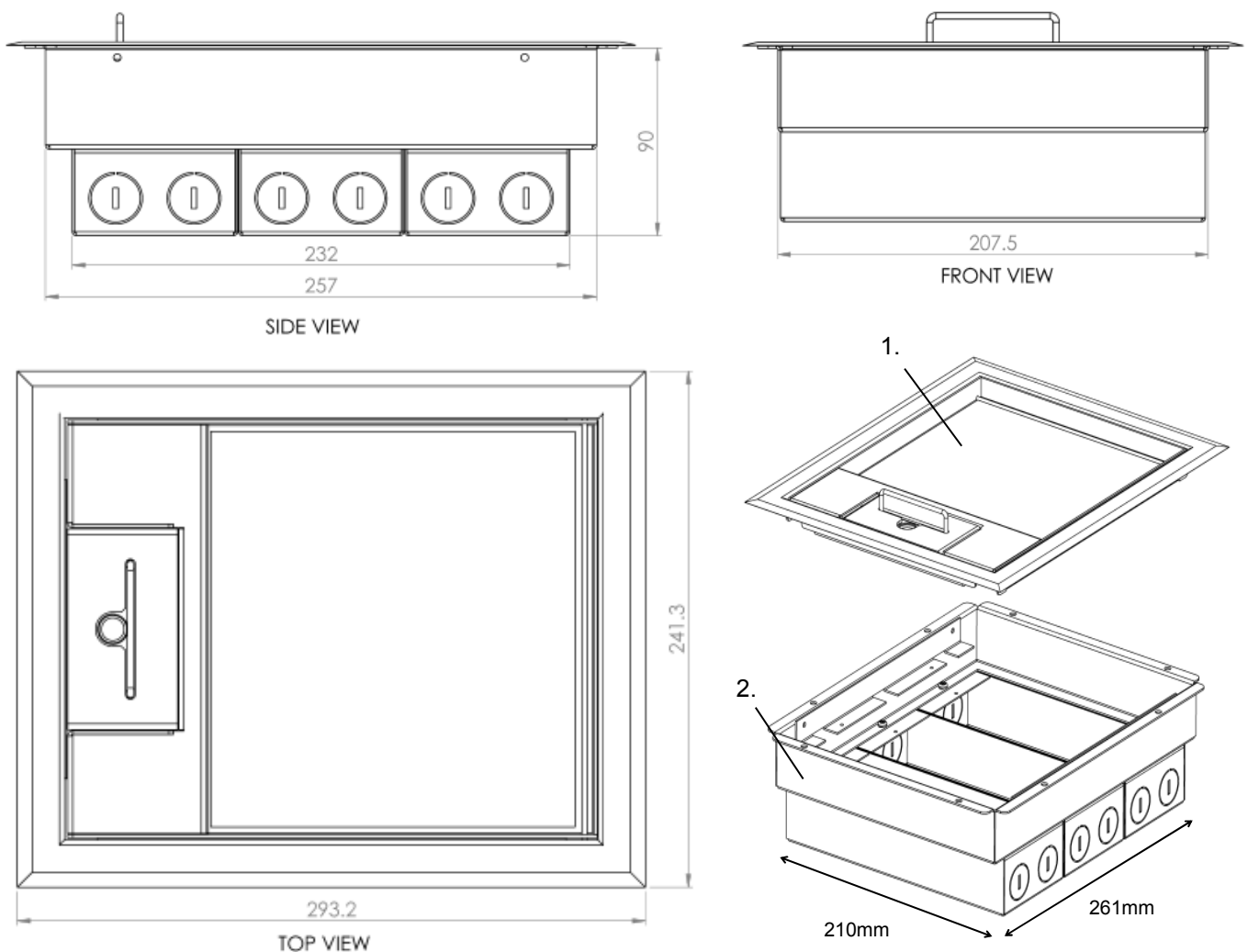

ITEM NO.	DESCRIPTION	QTY
1	APOLLO RECESSED STAINLESS STEEL LID	1
2	APOLLO FL SS 90MM UNDERCARRIAGE	1
Floorbox cut out dimensions: 261mm x 210mm		

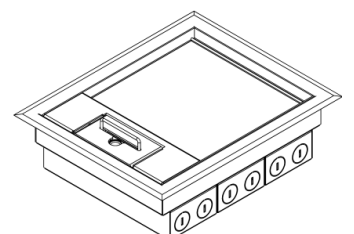

Floorbox: Apollo FL Recessed Stainless Steel Series

PART NO: FL3120SS

CMS Apollo FL Stainless Steel Recessed Module Floorbox - 3 Compartment, 120mm deep

TECHNICAL SPECIFICATIONS:

CMS 3 Compartment, 120mm deep Apollo FL SS floorbox with 12mm recessed stainless steel lid, easy to grab lifting handle and cable exit cap. The chassis and mounting plates are constructed from powder coated sheet steel with multiple cable entry points. **Load Capacity: 150kg**

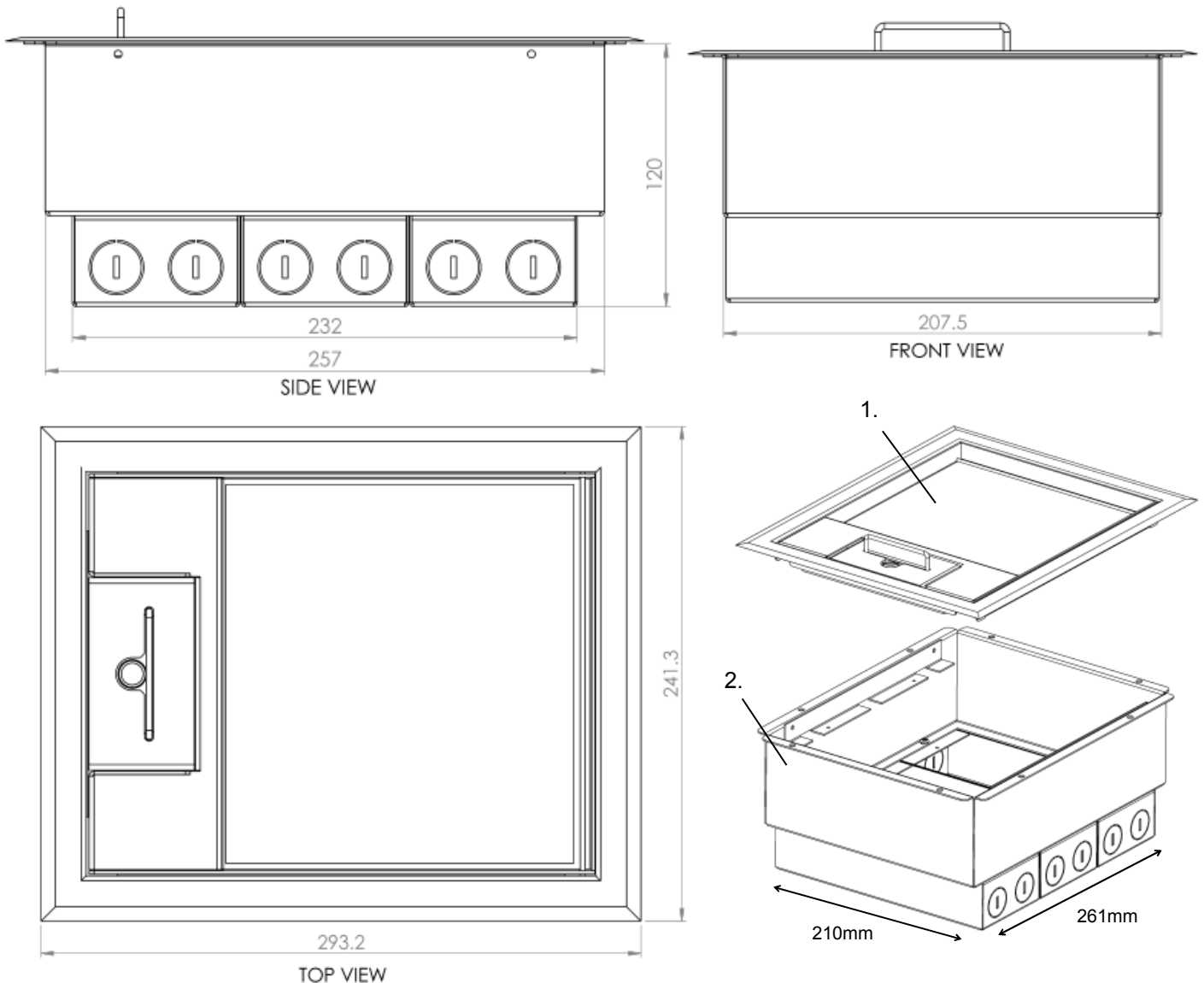

ITEM NO.	DESCRIPTION	QTY
1	APOLLO RECESSED STAINLESS STEEL LID	1
2	APOLLO FL SS 120MM UNDERCARRIAGE	1
Floorbox cut out dimensions: 261mm x 210mm		

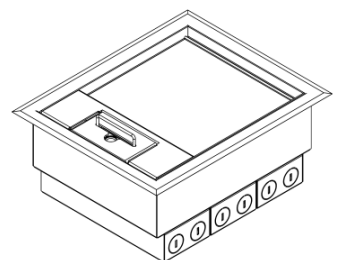

Floorbox: Apollo FL Recessed Stainless Steel Series

PART NO: FL4080SS

CMS Apollo FL Stainless Steel Recessed Module Floorbox - 4 Compartment, 80mm deep

TECHNICAL SPECIFICATIONS:

CMS 4 Compartment, 80mm deep Apollo FL SS floorbox with 12mm recessed stainless steel lid, easy to grab lifting handle and cable exit cap. The chassis and mounting plates are constructed from powder coated sheet steel with multiple cable entry points.

Load Capacity: 150kg

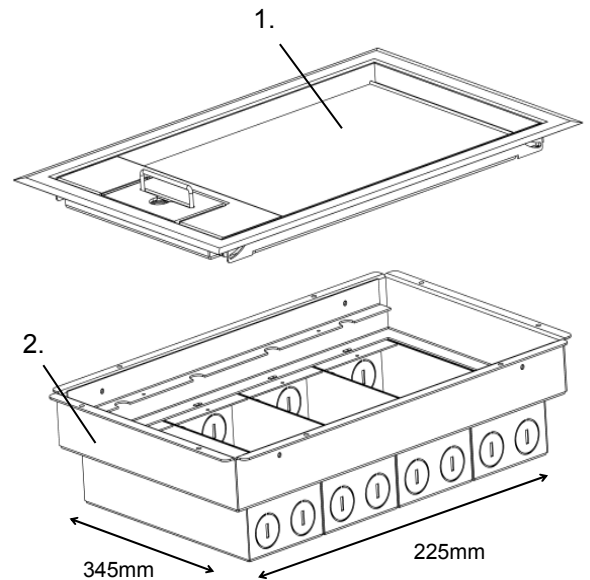
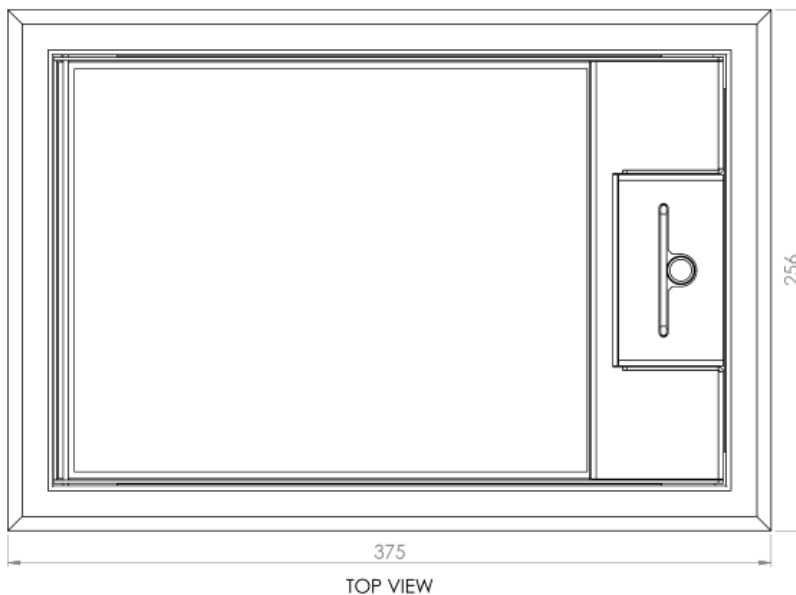
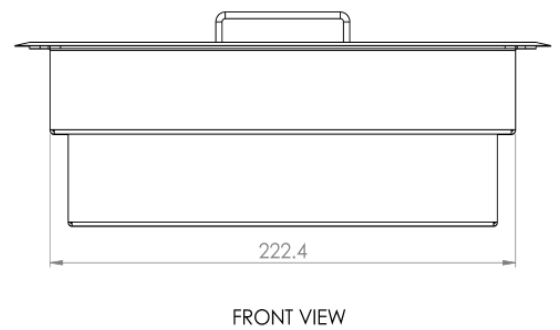
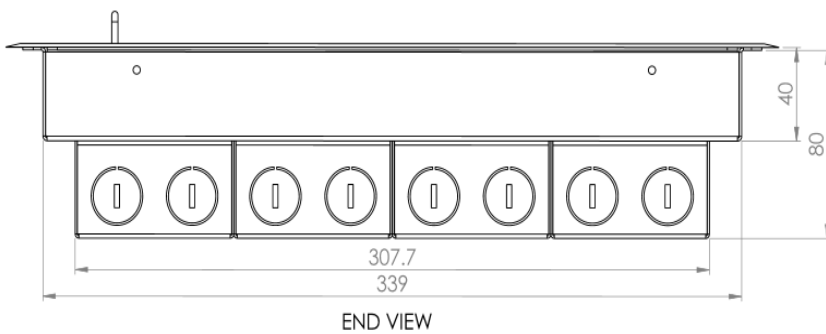

ITEM NO.	DESCRIPTION	QTY
1	APOLLO RECESSED STAINLESS STEEL LID LARGE	1
2	APOLLO FL SS 80MM LARGE UNDERCARRIAGE	1
Floorbox cut out dimensions: 345mm x 225mm		

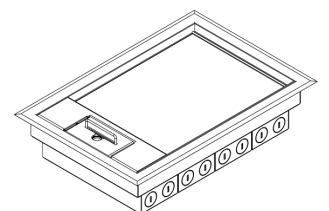

Floorbox: Apollo FL Recessed Stainless Steel Series

PART NO: FL4090SS

CMS Apollo FL Stainless Steel Recessed Module Floorbox - 4 Compartment, 90mm deep

TECHNICAL SPECIFICATIONS:

CMS 4 Compartment, 90mm deep Apollo FL SS floorbox with 12mm recessed stainless steel lid, easy to grab lifting handle and cable exit cap. The chassis and mounting plates are constructed from powder coated sheet steel with multiple cable entry points.

Load Capacity: 150kg

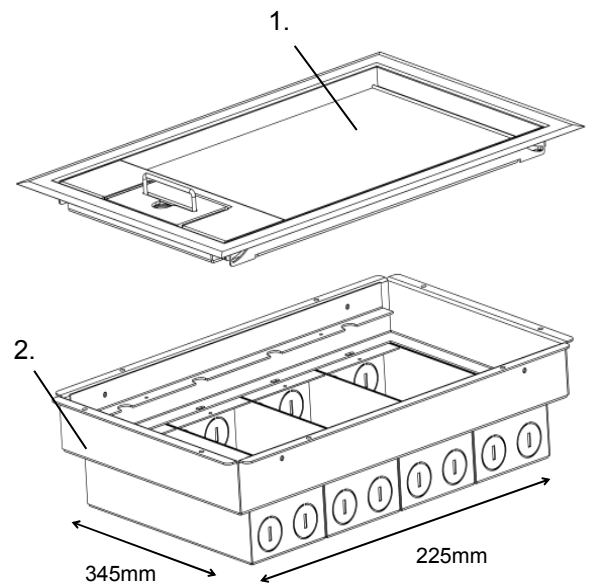
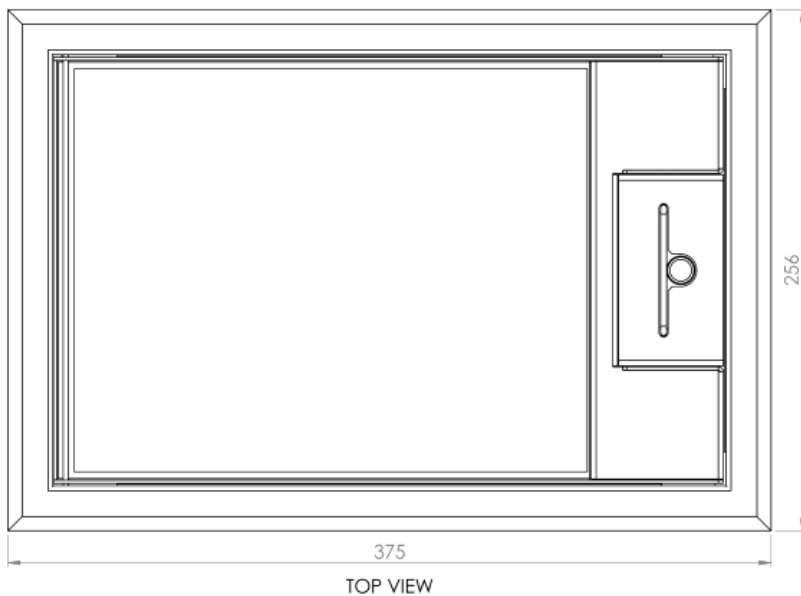
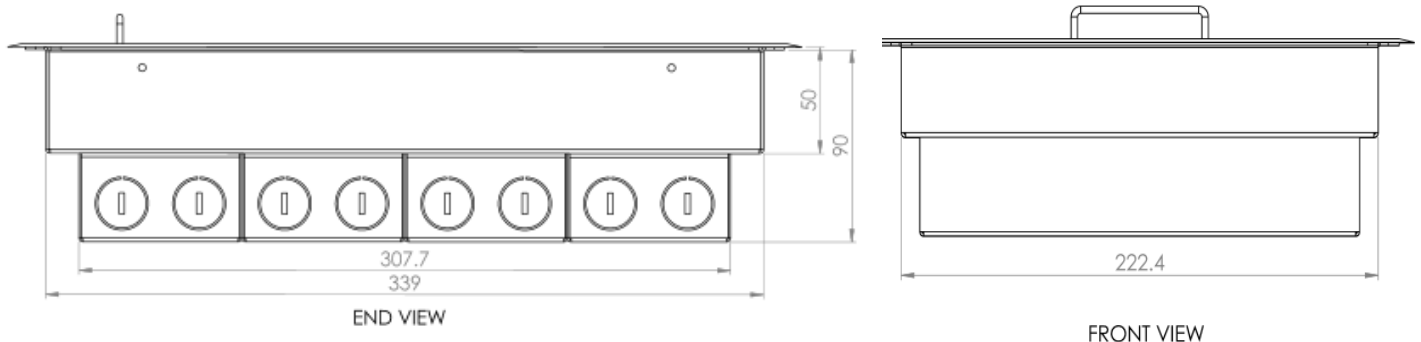

ITEM NO.	DESCRIPTION	QTY
1	APOLLO RECESSED STAINLESS STEEL LID LARGE	1
2	APOLLO FL SS 90MM LARGE UNDERCARRIAGE	1
Floorbox cut out dimensions: 345mm x 225mm		

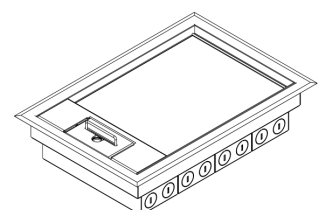

Floorbox: Apollo FL Recessed Stainless Steel Series

PART NO: FL4120SS

CMS Apollo FL Stainless Steel Recessed Module Floorbox - 4 Compartment, 120mm deep

TECHNICAL SPECIFICATIONS:

CMS 4 Compartment, 120mm deep Apollo FL SS floorbox with 12mm recessed stainless steel lid, easy to grab lifting handle and cable exit cap. The chassis and mounting plates are constructed from powder coated sheet steel with multiple cable entry points.

Load Capacity: 150kg

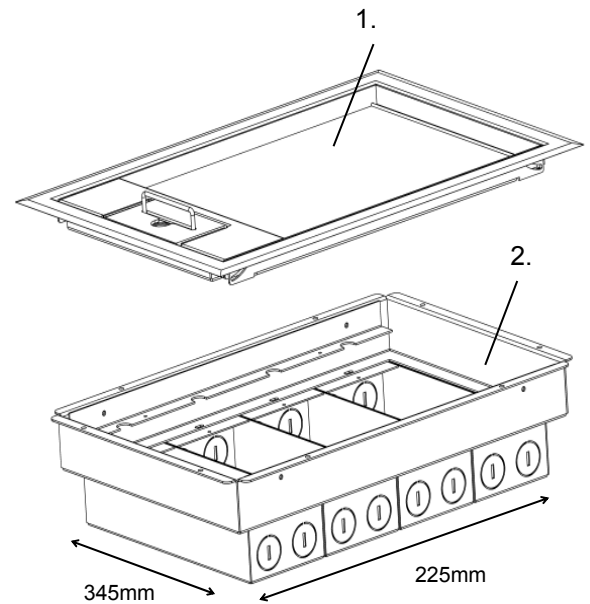
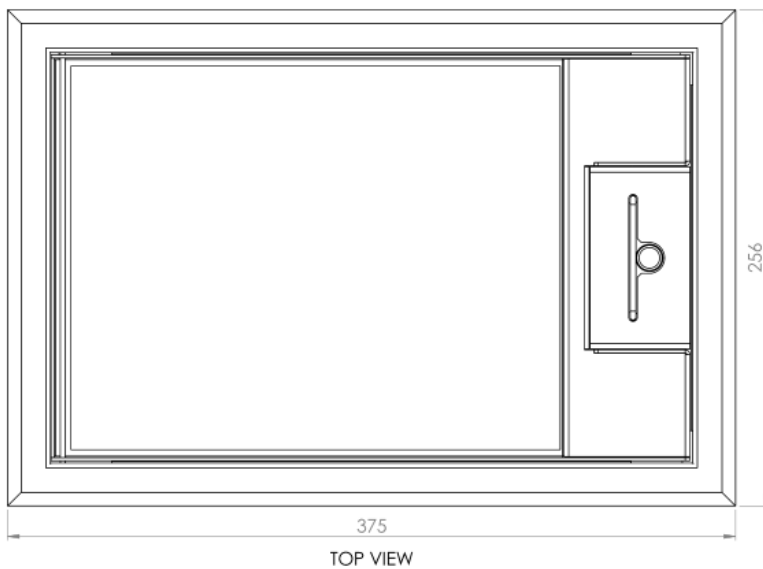
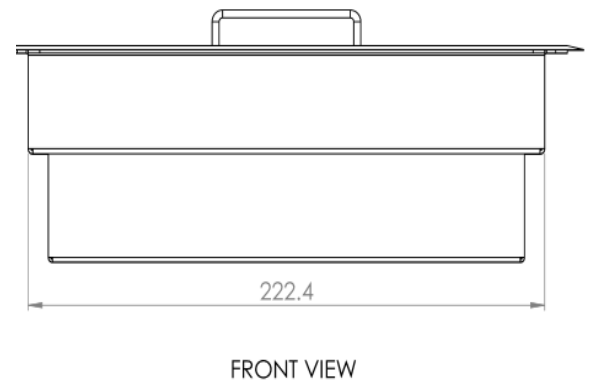
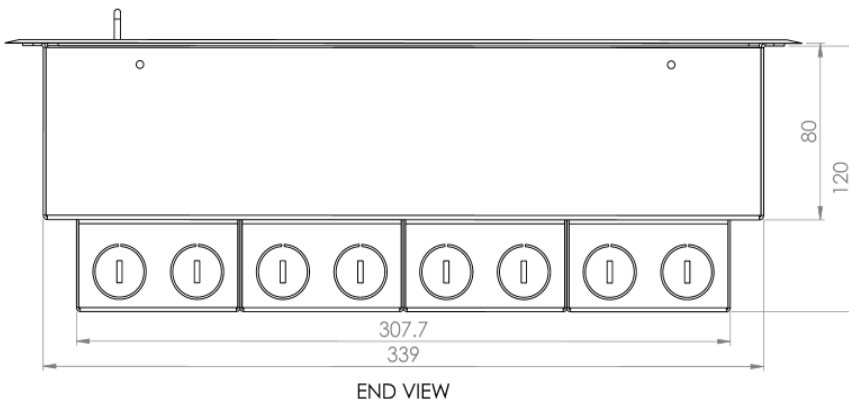

ITEM NO.	DESCRIPTION	QTY
1	APOLLO RECESSED STAINLESS STEEL LID LARGE	1
2	APOLLO FL SS 120MM LARGE UNDERCARRIAGE	1
Floorbox cut out dimensions: 345mm x 225mm		

Floorbox: Apollo FB Recessed Series

PART NO: FB260

CMS Apollo Module Floorbox - 60mm deep

TECHNICAL SPECIFICATIONS:

CMS Apollo FB floorbox with high-impact multi-directional Polycarbonate lid easy to grab lifting handle and oversized cable exit cap. The chassis and mounting plates are constructed from powder coated sheet steel with multiple cable entry points. **Load Capacity: 120kg**

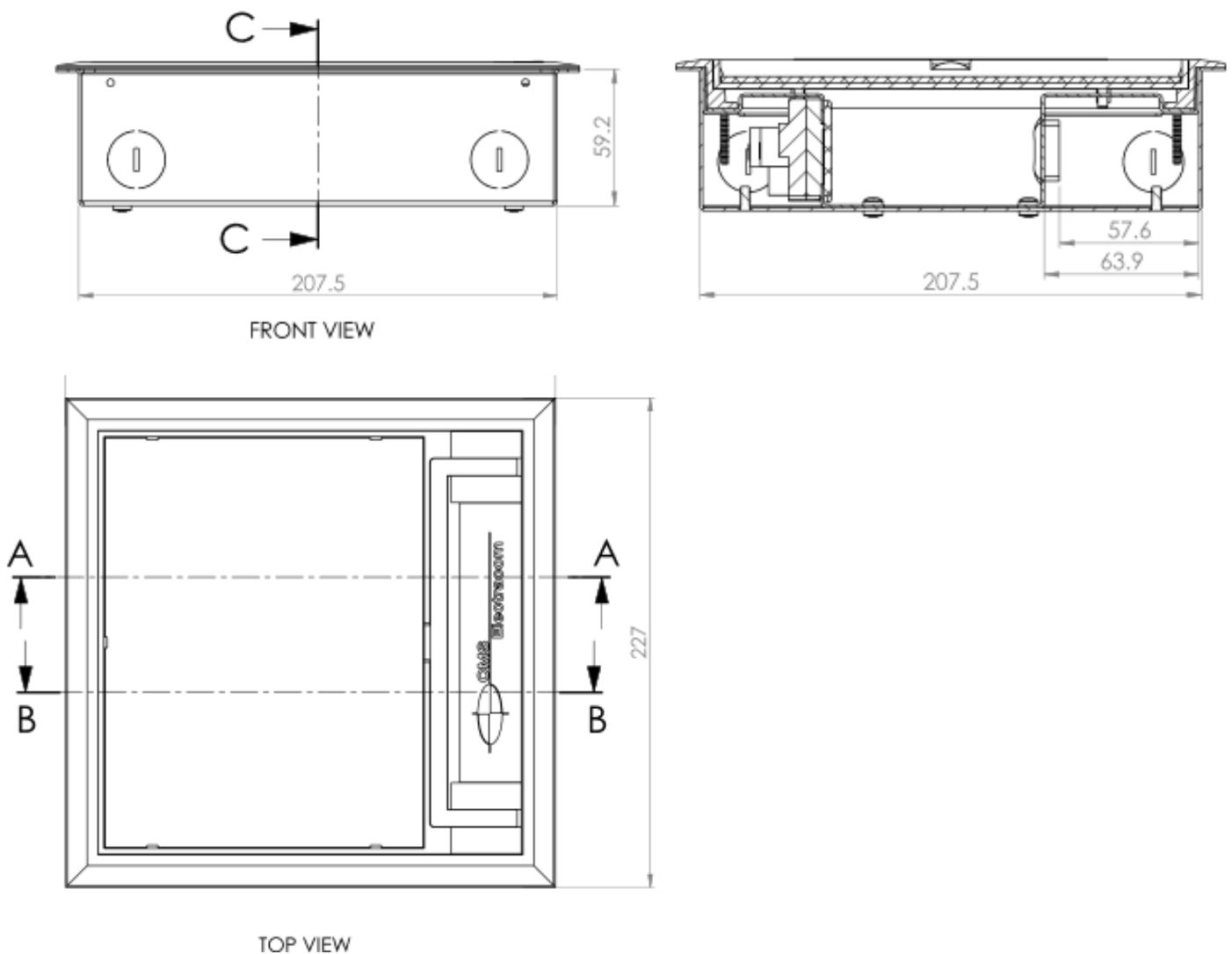

ITEM NO.	DESCRIPTION	QTY
1	APOLLO FB LID	1
2	APOLLO FB 60MM UNDERCARRIAGE	1

Floorbox cut out dimensions: 210mm x 210mm

Floorbox: Apollo FB Recessed Series

PART NO: FB280

CMS Apollo Module Floorbox - 80mm deep

TECHNICAL SPECIFICATIONS:

CMS Apollo FB floorbox with high-impact multi-directional polycarbonate lid, easy to grab lifting handle and oversized cable exit cap. Lid has a bevelled edge carpet frame and 7mm carpet recess. The chassis and mounting plates are constructed from powder coated sheet steel with multiple cable entry points. **Load Capacity: 120kg**

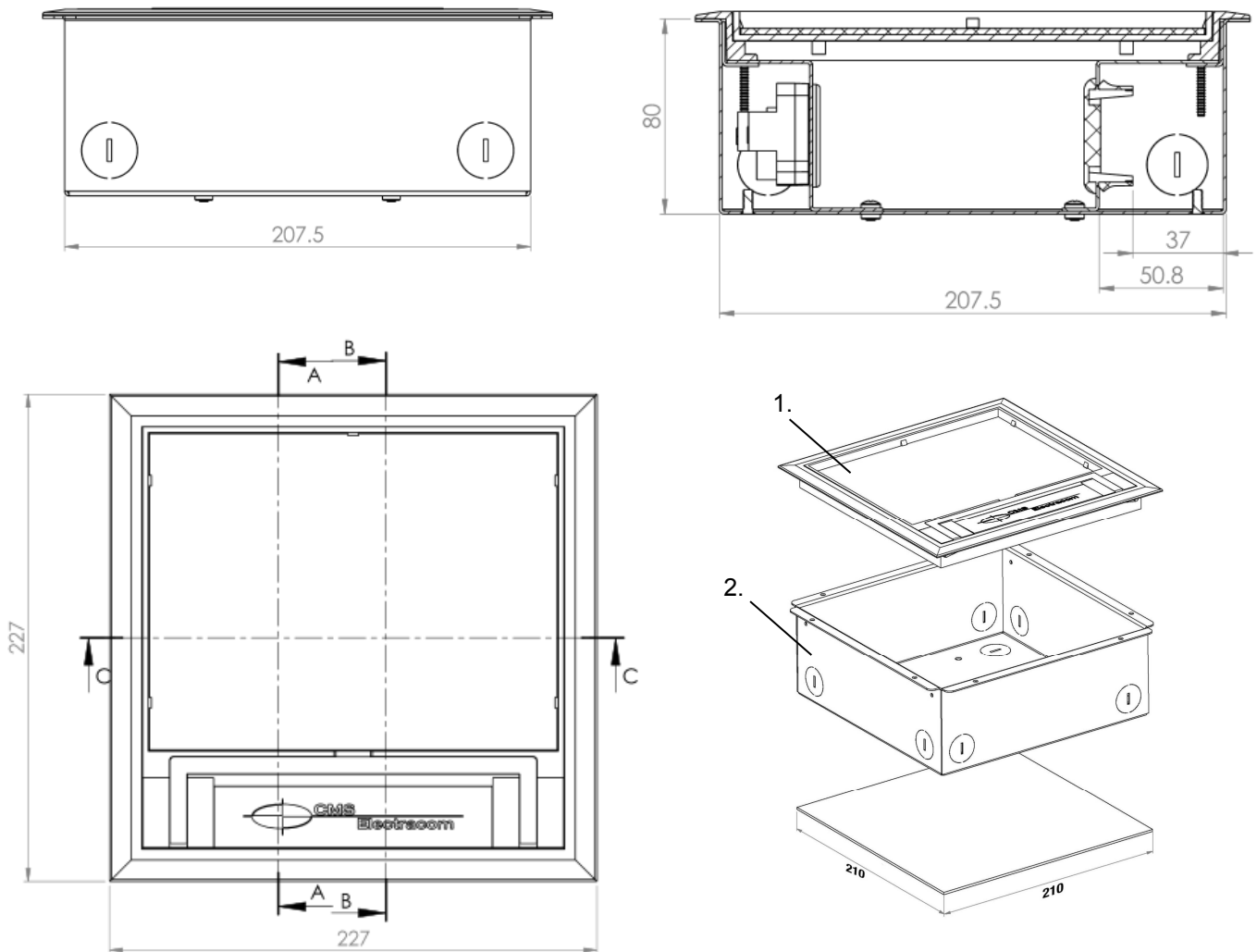

ITEM NO.	DESCRIPTION	QTY
1	APOLLO FB LID WITH RECESS	1
2	APOLLO FB 80MM UNDERCARRIAGE	1

Floorbox cut out dimensions: 210mm x 210mm

Floorbox: Apollo FB Recessed Series

PART NO: FB210

CMS Apollo Module Floorbox - 100mm deep

TECHNICAL SPECIFICATIONS:

CMS Apollo FB floorbox with high-impact multi-directional Polycarbonate lid, easy to grab lifting handle and oversized cable exit cap. Lid has a bevelled edge carpet frame and 7mm carpet recess. The chassis and mounting plates are constructed from powder coated sheet steel with multiple cable entry points. **Load Capacity: 120kg**

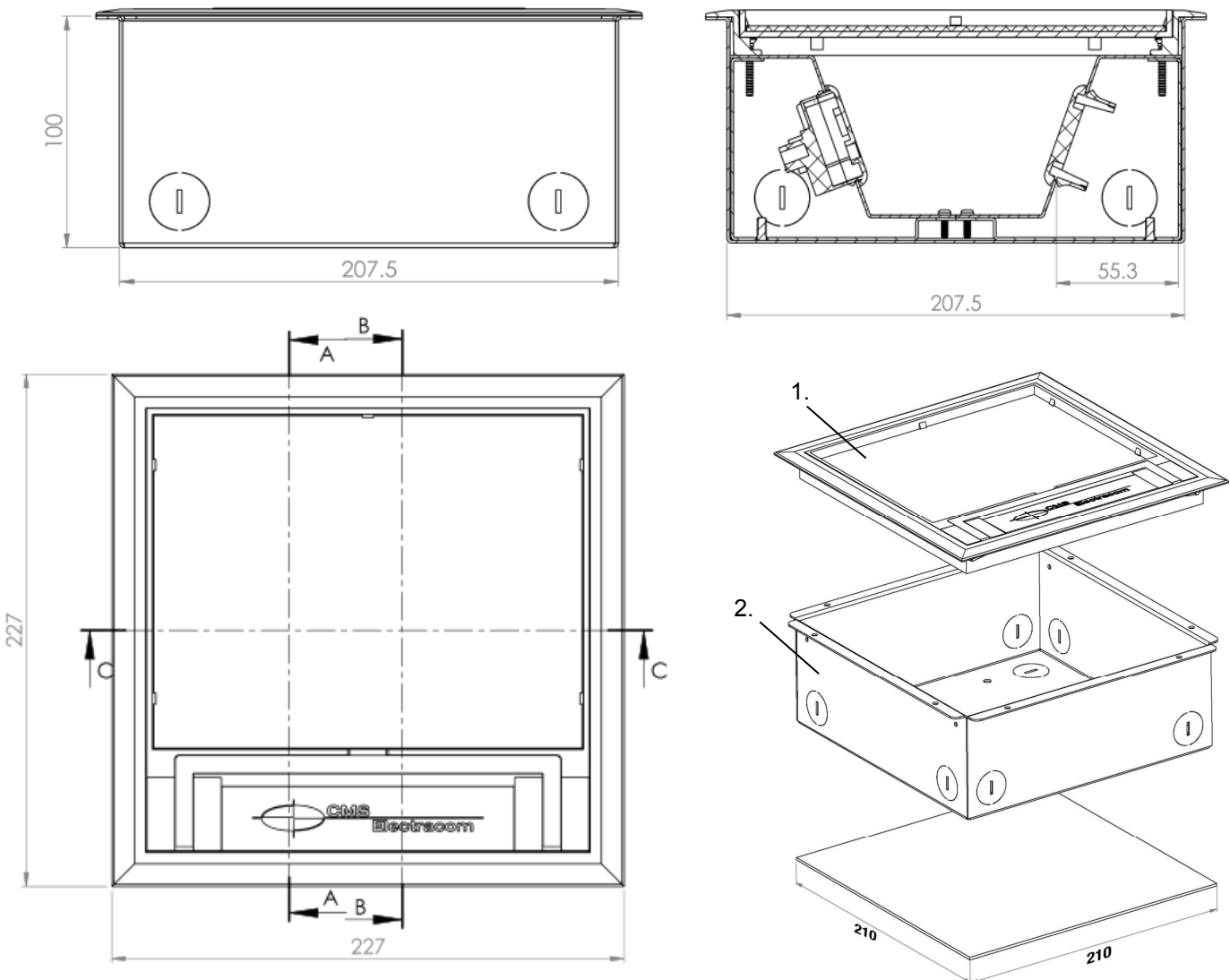

ITEM NO.	DESCRIPTION	QTY
1	APOLLO FB LID	1
2	APOLLO FB 100MM UNDERCARRIAGE	1
Floorbox cut out dimensions: 210mm x 210mm		

Floorbox: Apollo FB Recessed Series

PART NO: FB360

CMS Apollo Module Floorbox - 60mm deep - Available in Black only.

TECHNICAL SPECIFICATIONS:

CMS Apollo FB floorbox with high-impact multi-directional Polycarbonate lid, easy to grab lifting handle and oversized cable exit cap. Lid has a bevelled edge carpet frame and 7mm carpet recess. The chassis and mounting plates are constructed from powder coated sheet steel with multiple cable entry points. **Load Capacity: 120kg**

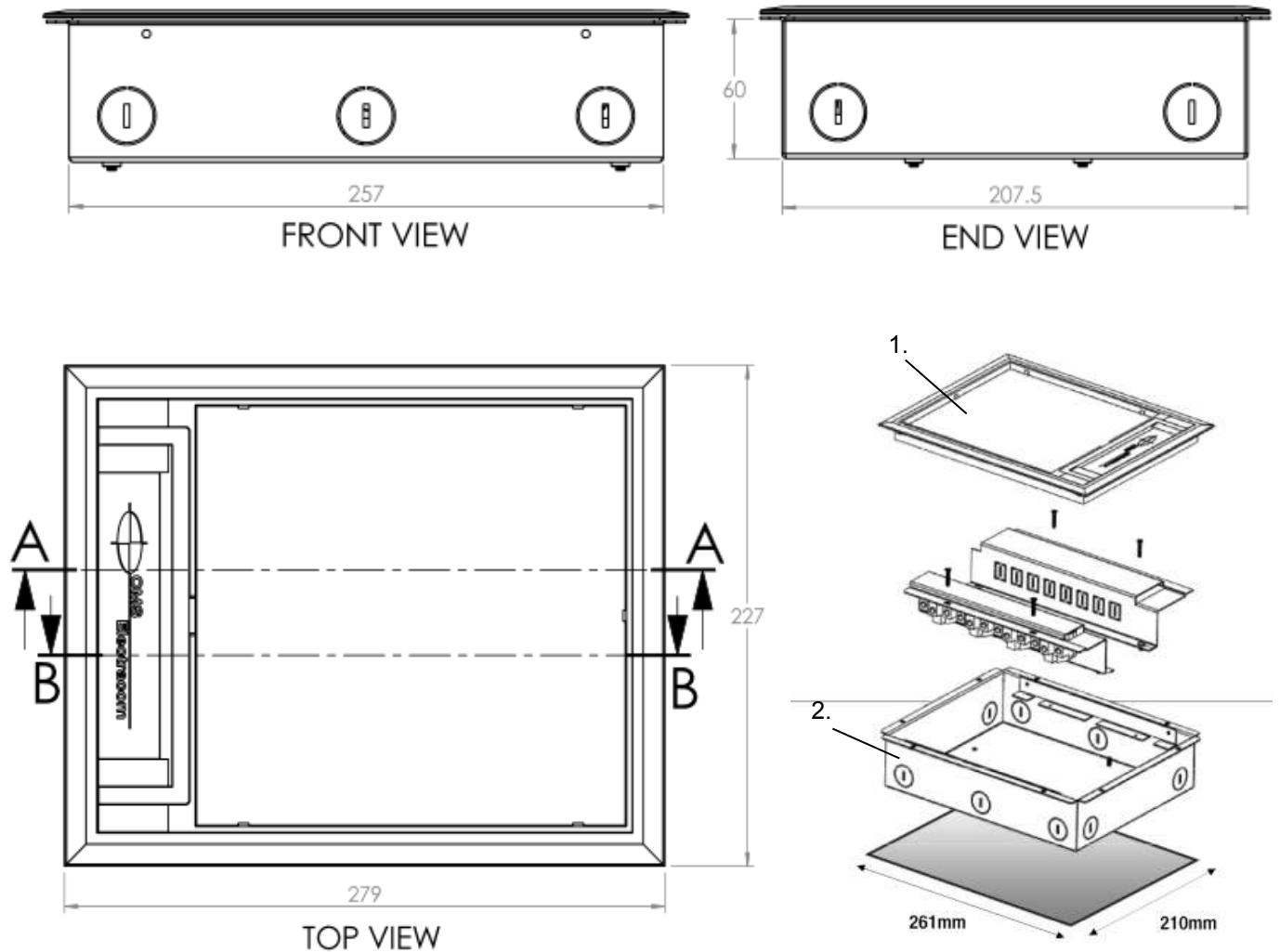

ITEM NO.	DESCRIPTION	QTY
1	APOLLO FB LID	1
2	APOLLO FB 60MM UNDERCARRIAGE	1
Floorbox cut out dimensions: 261mm x 210mm		

Floorbox: Apollo FB Recessed Series

PART NO: FB460

CMS Apollo Module Floorbox - 60mm deep

TECHNICAL SPECIFICATIONS:

CMS Apollo FB floorbox with high-impact multi-directional Polycarbonate lid, easy to grab lifting handle and oversized cable exit cap. Lid has a bevelled edge carpet frame and 7mm carpet recess. The chassis and mounting plates are constructed from powder coated sheet steel with multiple cable entry points. **Load Capacity: 120kg**

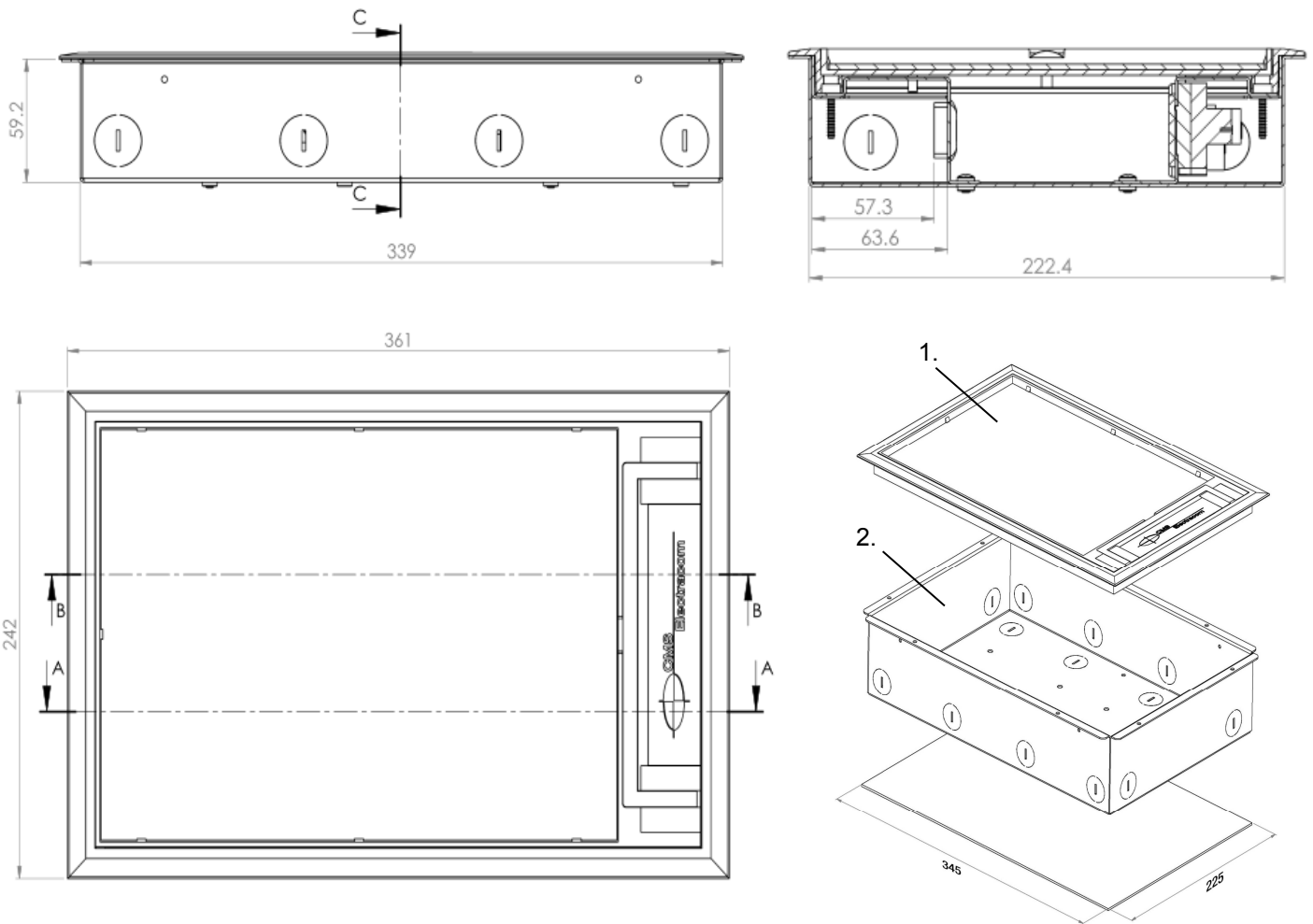

ITEM NO.	DESCRIPTION	QTY
1	APOLLO FB LID	1
2	APOLLO FB 60MM UNDERCARRIAGE	1
Floorbox cut out dimensions: 345mm x 225mm		

Floorbox: Apollo FB Recessed Series

PART NO: FB480

CMS Apollo Module Floorbox - 80mm deep

TECHNICAL SPECIFICATIONS:

CMS Apollo FB floorbox with high-impact multi-directional Polycarbonate lid, easy to grab lifting handle and oversized cable exit cap. Lid has a bevelled edge carpet frame and 7mm carpet recess. The chassis and mounting plates are constructed from powder coated sheet steel with multiple cable entry points. **Load Capacity: 120kg**

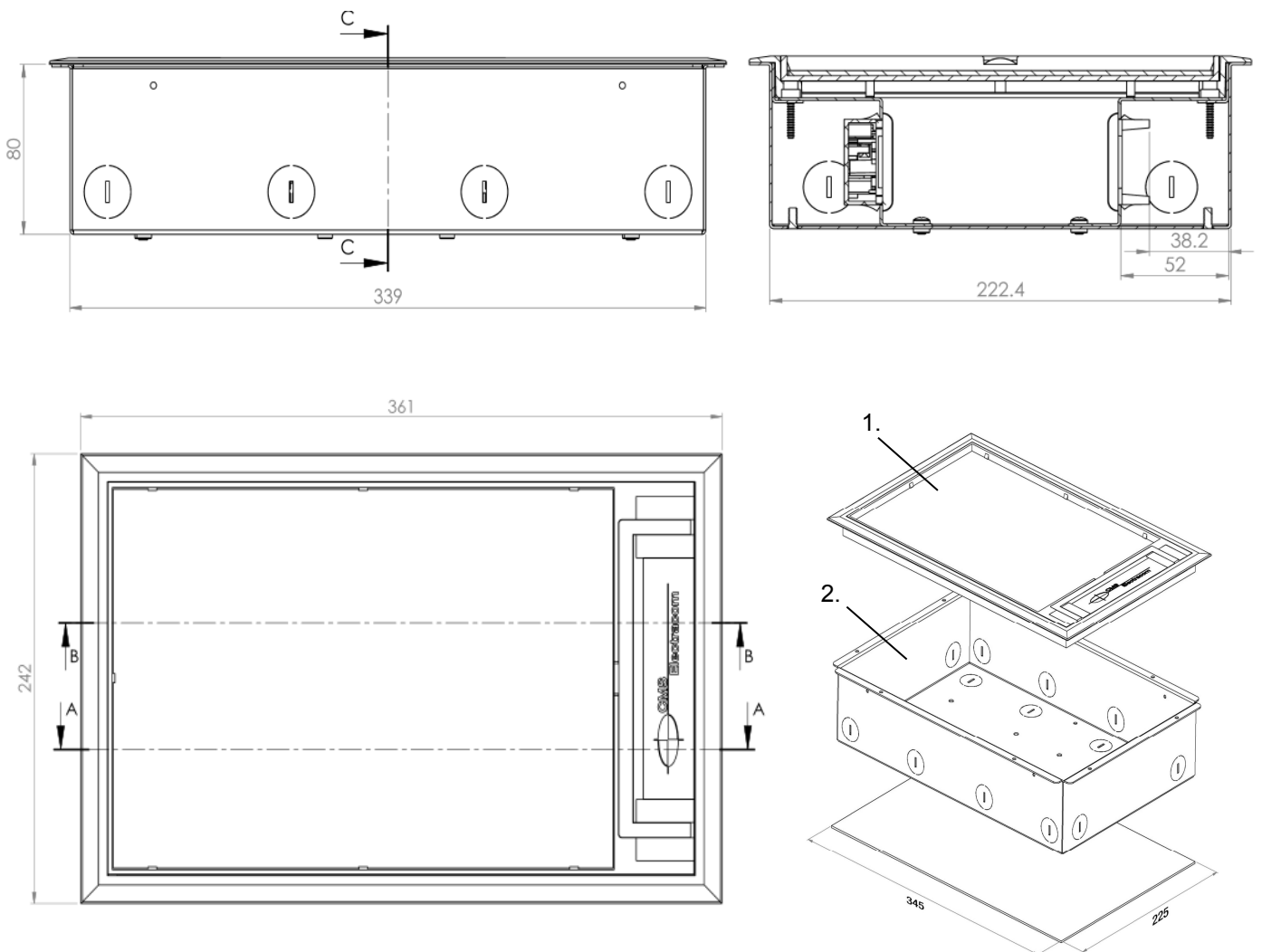

ITEM NO.	DESCRIPTION	QTY
1	APOLLO FB LID	1
2	APOLLO FB 80MM UNDERCARRIAGE	1
Floorbox cut out dimensions: 345mm x 225mm		

Floorbox: Apollo FB Recessed Series

PART NO: FB410

CMS Apollo FB Module Floorbox - 100mm deep

TECHNICAL SPECIFICATIONS:

CMS Apollo FB floorbox with high-impact multi-directional Polycarbonate lid, easy to grab lifting handle and oversized cable exit cap. Lid has a bevelled edge carpet frame and 7mm carpet recess. The chassis and mounting plates are constructed from powder coated sheet steel with multiple cable entry points. **Load Capacity: 120kg**

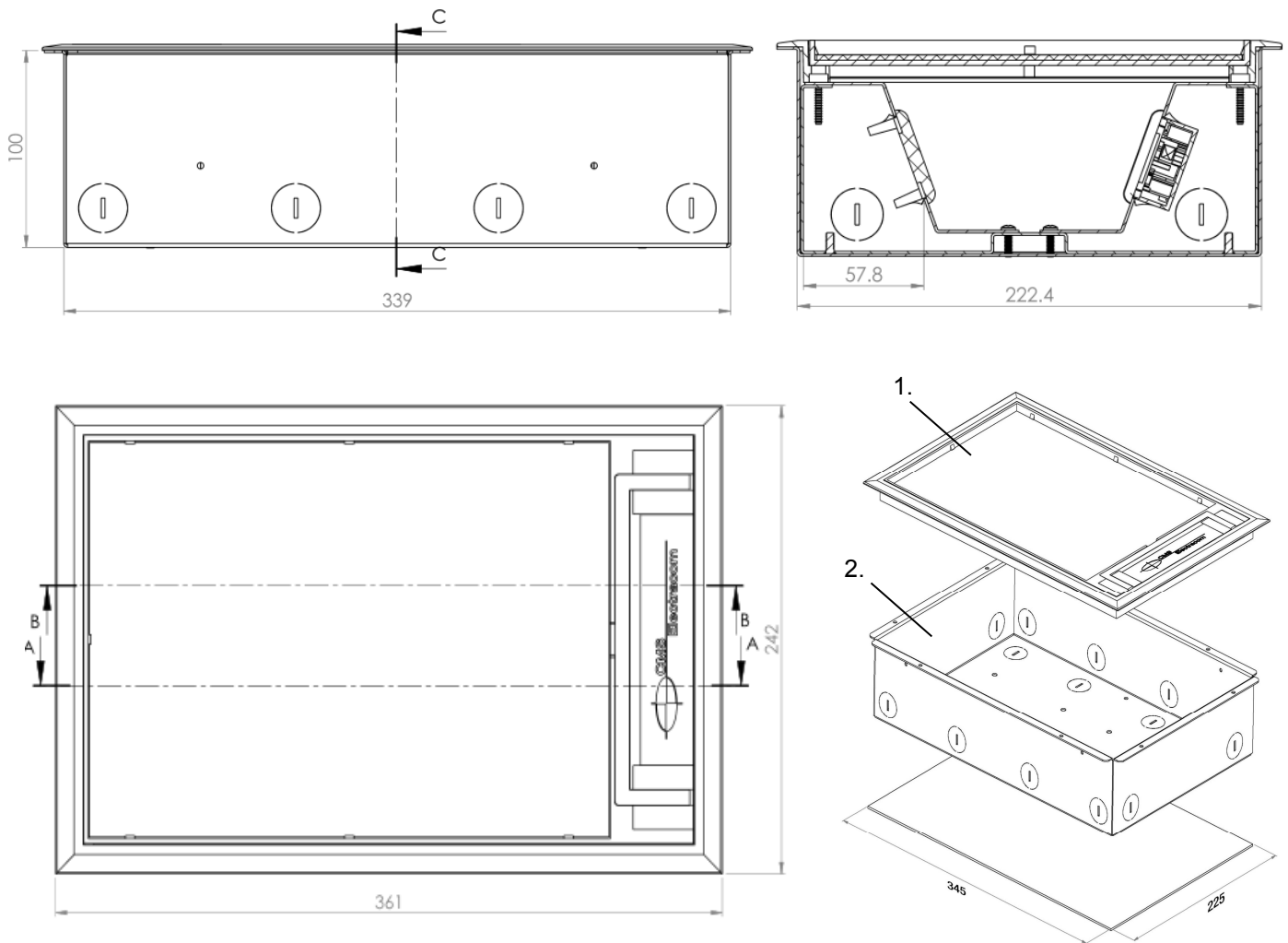

ITEM NO.	DESCRIPTION	QTY
1	APOLLO FB LID	1
2	APOLLO FB 100MM UNDERCARRIAGE	1
Floorbox cut out dimensions: 345mm x 225mm		

Floorbox: Rhino Stainless Steel Series

PART NO: RF2080SS

CMS Rhino Stainless Steel Floorbox - 2 Compartment, 80mm deep

TECHNICAL SPECIFICATIONS:

CMS 2 compartment , 80mm deep Rhino floorbox flush mount lid is manufactured from 5mm stainless steel and is suitable in applications requiring additional strength and easily installed into a concrete or timber floor. Accessory boxes come in galvanised steel. The chassis and mounting plates are constructed from powder coated sheet steel with multiple knockouts for conduit. **Load Capacity: 400kg**

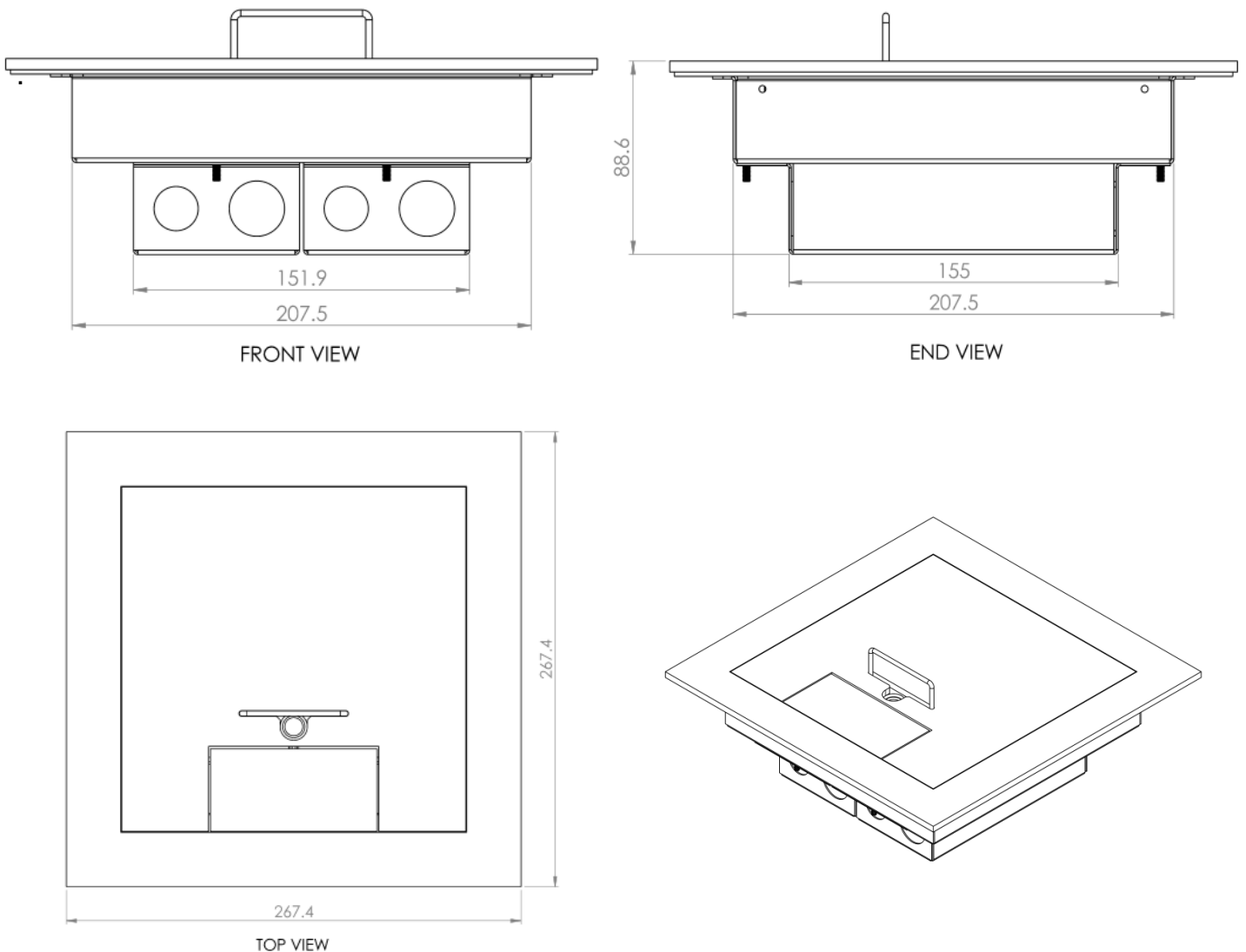

ITEM NO.	DESCRIPTION	QTY
1	RHINO STAINLESS STEEL LID	1
2	RHINO SS 80MM UNDERCARRIAGE	1
Floorbox cut out dimensions: 210mm x 210mm		

Floorbox: Rhino Stainless Steel Series

PART NO: RF2090SS

CMS Rhino Stainless Steel Floorbox - 2 Compartment, 90mm deep

TECHNICAL SPECIFICATIONS:

CMS 2 compartment , 90mm deep Rhino floorbox flush mount lid is manufactured from 5mm stainless steel and is suitable in applications requiring additional strength and easily installed into a concrete or timber floor. Accessory boxes come in galvanised steel. The chassis and mounting plates are constructed from powder coated sheet steel with multiple knockouts for conduit. **Load Capacity: 400kg**

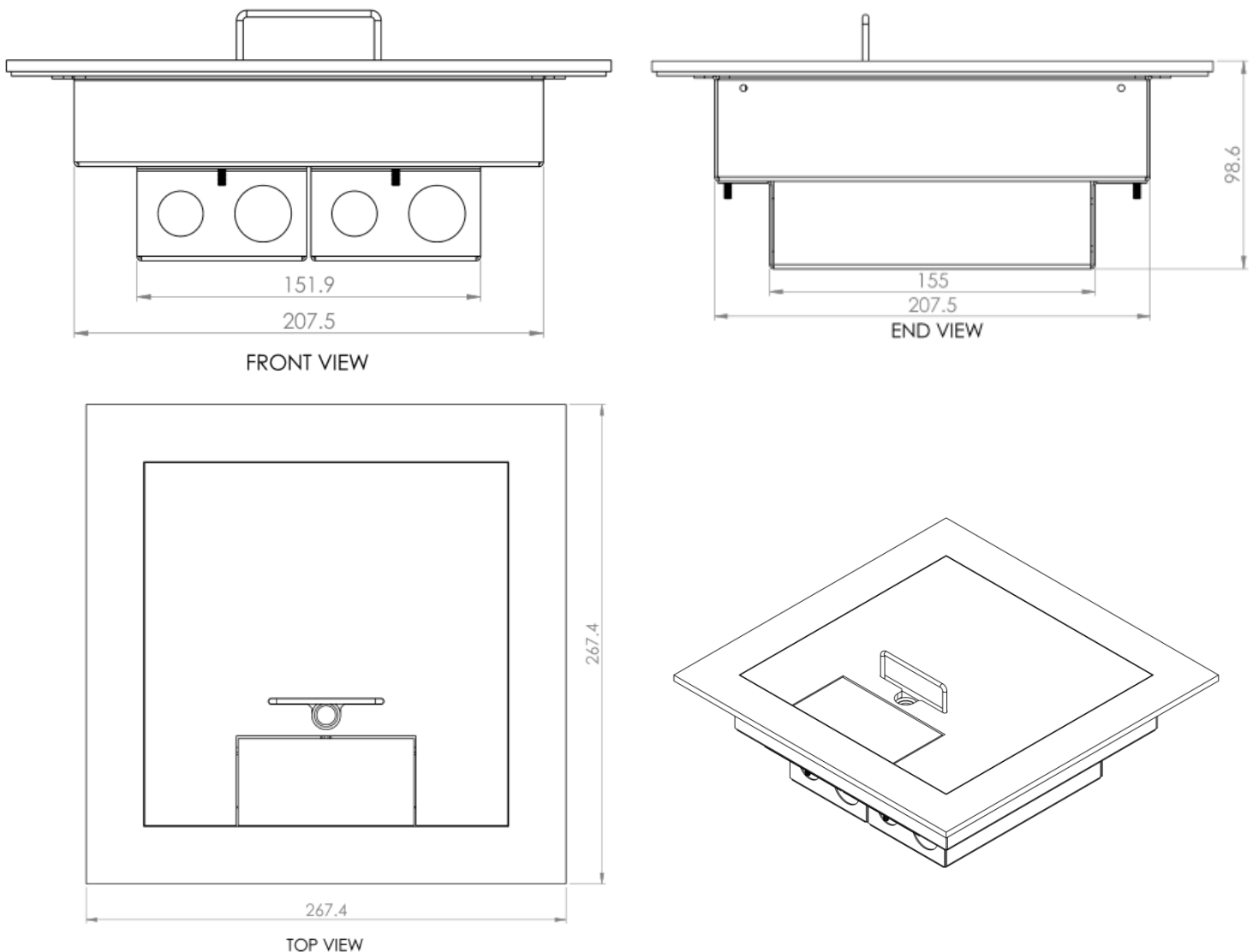

ITEM NO.	DESCRIPTION	QTY
1	RHINO STAINLESS STEEL LID	1
2	RHINO SS 90MM UNDERCARRIAGE	1

Floorbox cut out dimensions: 210mm x 210mm

Floorbox: Rhino Stainless Steel Series

PART NO: RF2120SS

CMS Rhino Stainless Steel Floorbox - 2 Compartment, 120mm deep

TECHNICAL SPECIFICATIONS:

CMS 2 compartment , 120mm deep Rhino floorbox flush mount lid is manufactured from 5mm stainless steel and is suitable in applications requiring additional strength and easily installed into a concrete or timber floor. Accessory boxes come in galvanised steel. The chassis and mounting plates are constructed from powder coated sheet steel with multiple knockouts for conduit. **Load Capacity: 400kg**

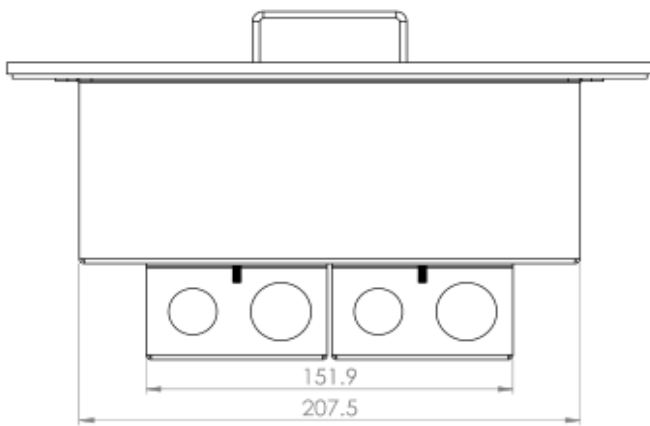

FRONT VIEW

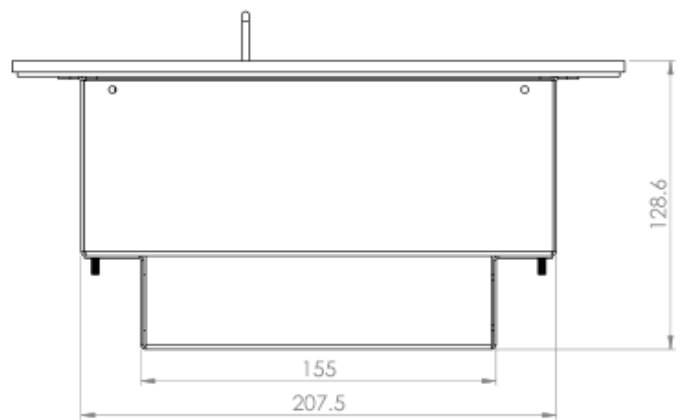

END VIEW

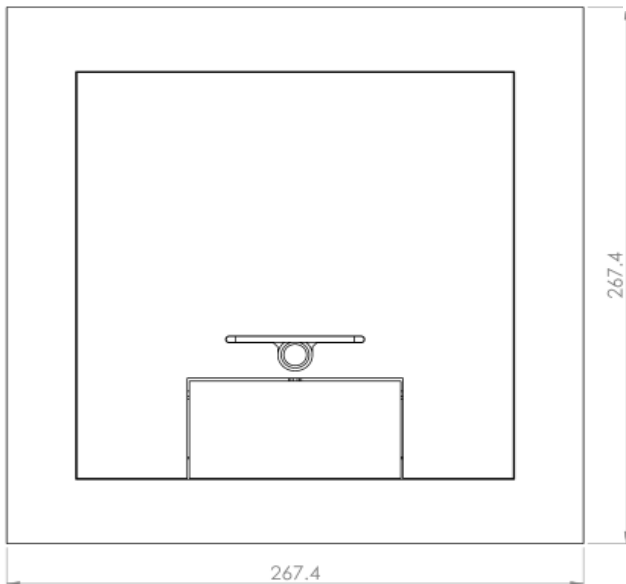

TOP VIEW

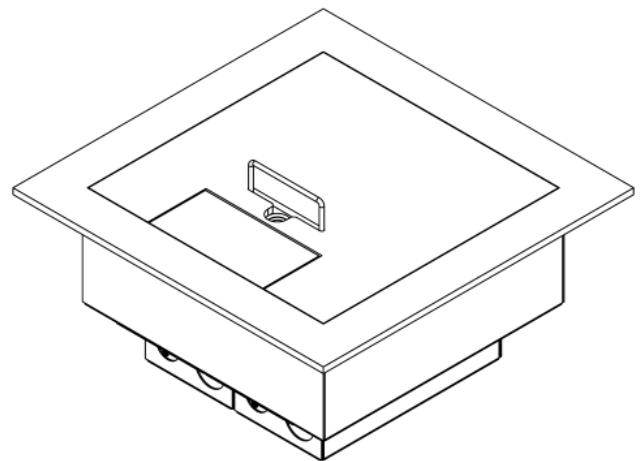

ITEM NO.	DESCRIPTION	QTY
1	RHINO STAINLESS STEEL LID -	1
2	RHINO SS 120MM UNDERCARRIAGE	1
Floorbox cut out dimensions: 210mm x 210mm		

Floorbox: Rhino Stainless Steel Series

PART NO: RF4080SS

CMS Rhino Stainless Steel Floorbox - 4 Compartment, 80mm deep

TECHNICAL SPECIFICATIONS:

CMS 4 compartment , 80mm deep Rhino floorbox flush mount lid is manufactured from 5mm stainless steel and is suitable in applications requiring additional strength and easily installed into a concrete or timber floor. Accessory boxes come in galvanised steel. The chassis and mounting plates are constructed from powder coated sheet steel with multiple knockouts for conduit. **Load Capacity: 400kg**

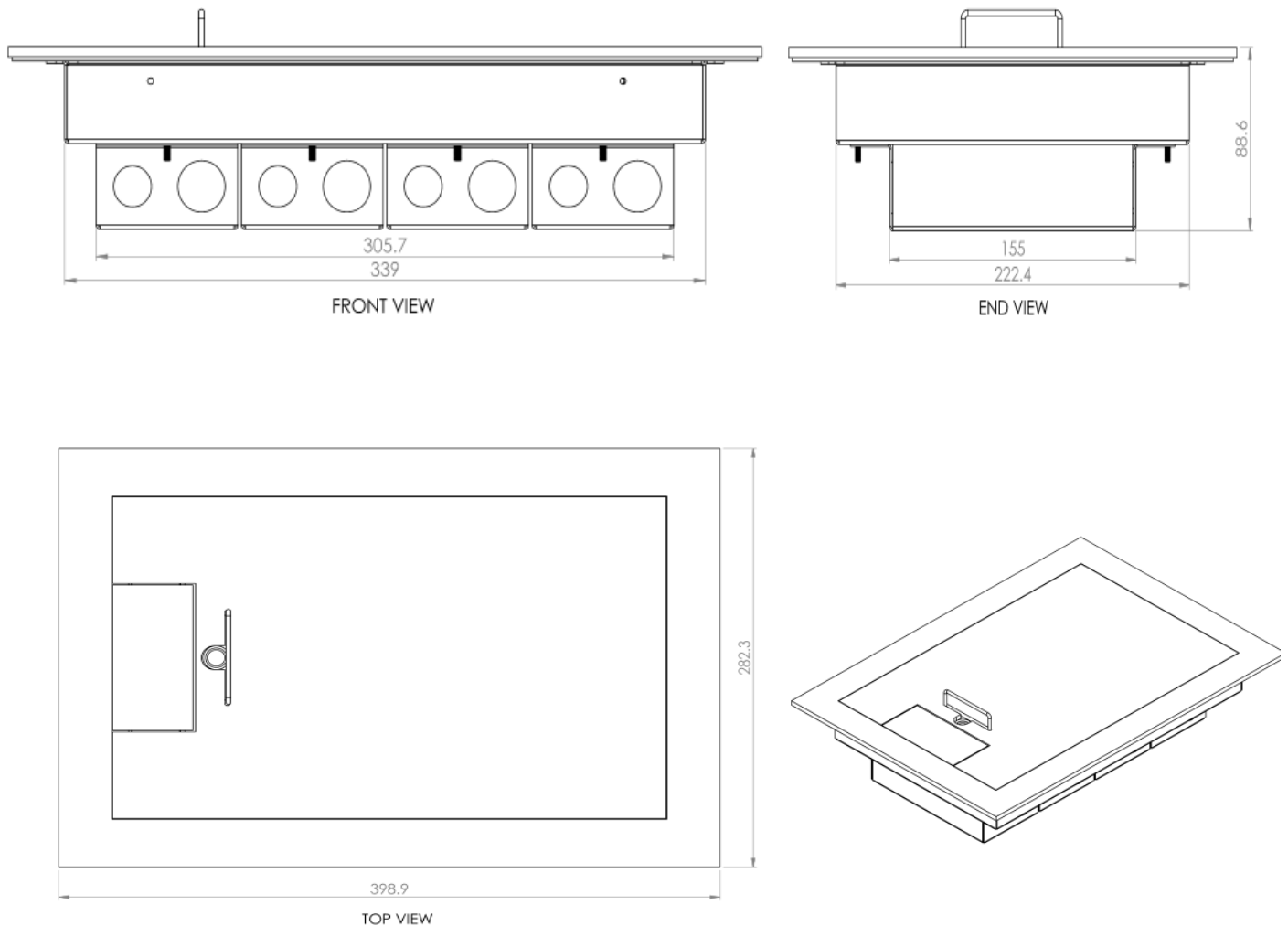

ITEM NO.	DESCRIPTION	QTY
1	RHINO STAINLESS STEEL LID - LARGE	1
2	RHINO SS 80MM LARGE UNDERCARRIAGE	1
Floorbox cut out dimensions: 345mm X 225mm		

Floorbox: Rhino Stainless Steel Series

PART NO: RF4090SS

CMS Rhino Stainless Steel Floorbox - 4 Compartment, 90mm deep

TECHNICAL SPECIFICATIONS:

CMS 4 compartment , 90mm deep Rhino floorbox flush mount lid is manufactured from 5mm stainless steel and is suitable in applications requiring additional strength and easily installed into a concrete or timber floor. Accessory boxes come in galvanised steel. The chassis and mounting plates are constructed from powder coated sheet steel with multiple knockouts for conduit. **Load Capacity: 400kg**

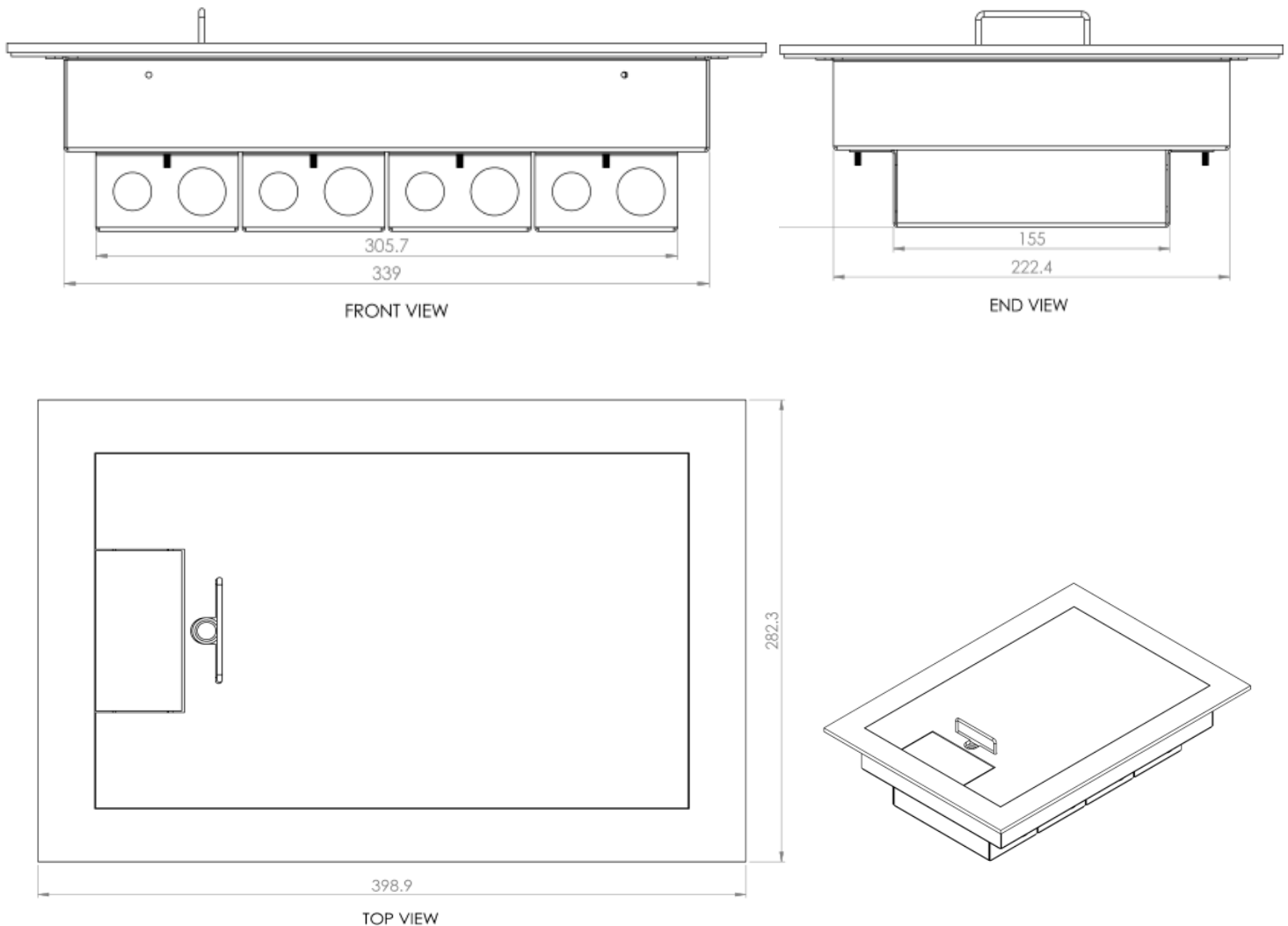

ITEM NO.	DESCRIPTION	QTY
1	RHINO STAINLESS STEEL LID - LARGE	1
2	RHINO SS 90MM LARGE UNDERCARRIAGE	1
Floorbox cut out dimensions: 345mm X 225mm		

Floorbox: Rhino Stainless Steel Series

PART NO: RF4120SS

CMS Rhino Stainless Steel Floorbox - 4 Compartment, 120mm deep

TECHNICAL SPECIFICATIONS:

CMS 4 compartment , 120mm deep Rhino floorbox flush mount lid is manufactured from 5mm stainless steel and is suitable in applications requiring additional strength and easily installed into a concrete or timber floor. Accessory boxes come in galvanised steel. The chassis and mounting plates are constructed from powder coated sheet steel with multiple knockouts for conduit. **Load Capacity: 400kg**

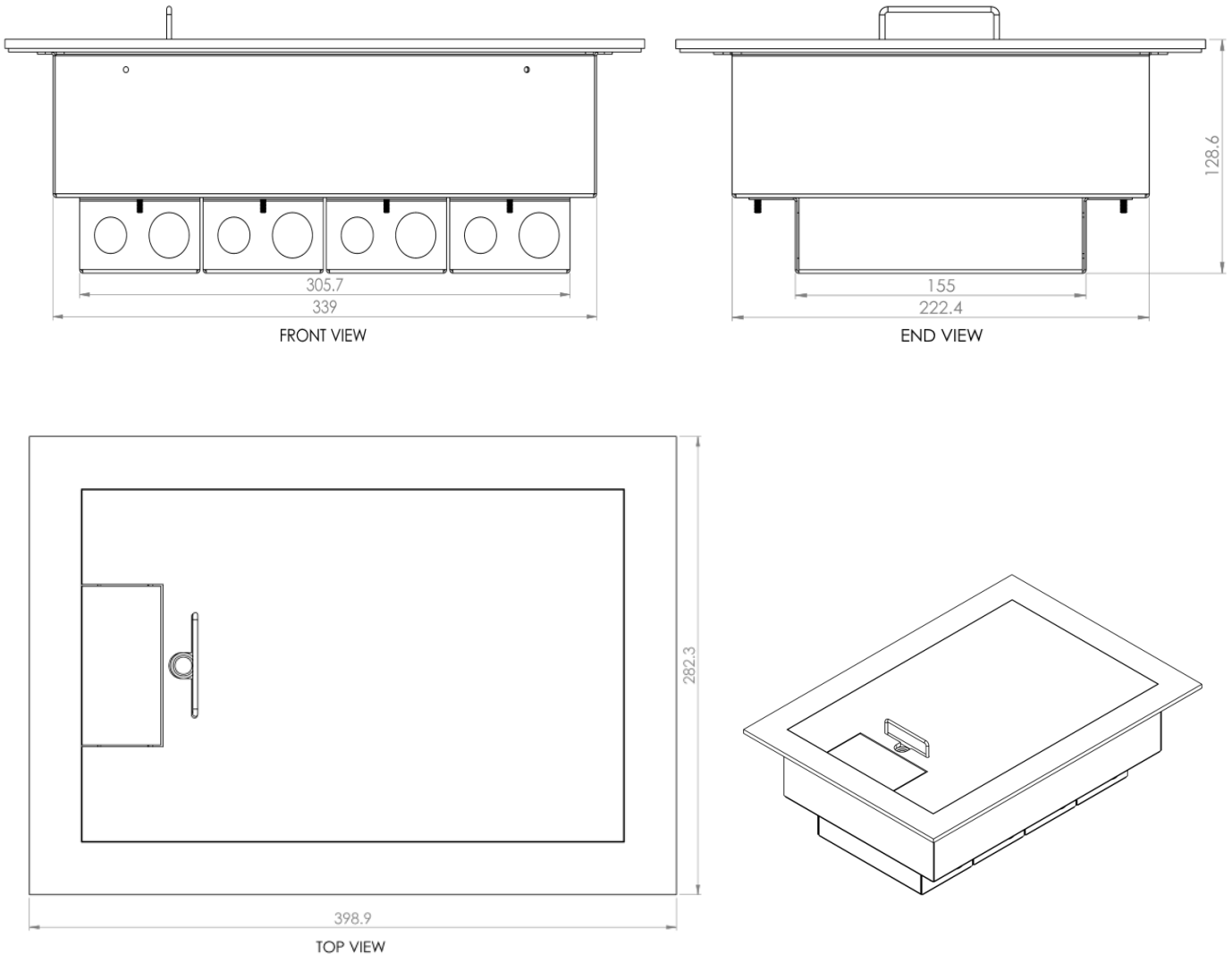

ITEM NO.	DESCRIPTION	QTY
1	RHINO STAINLESS STEEL LID - LARGE	1
2	RHINO SS 120MM LARGE UNDERCARRIAGE	1
Floorbox cut out dimensions: 345mm X 225mm		

Floorbox: 3 Phase Stainless Steel Series

PART NO: RF4B5120SS

CMS 3 Phase Stainless Steel Floorbox - 120mm deep

TECHNICAL SPECIFICATIONS:

CMS 3 Phase stainless steel, 120mm deep floorbox flush mount lid is manufactured from 5mm stainless steel and is suitable in applications requiring additional strength to take the weight of a vehicle and easily installed into a concrete or timber floor. The carcass and mounting plates are constructed from powder coated steel. Floorbox caters for dual 32amp outlets and 3 x CMS GPO modules. **Load Capacity: 400kg**

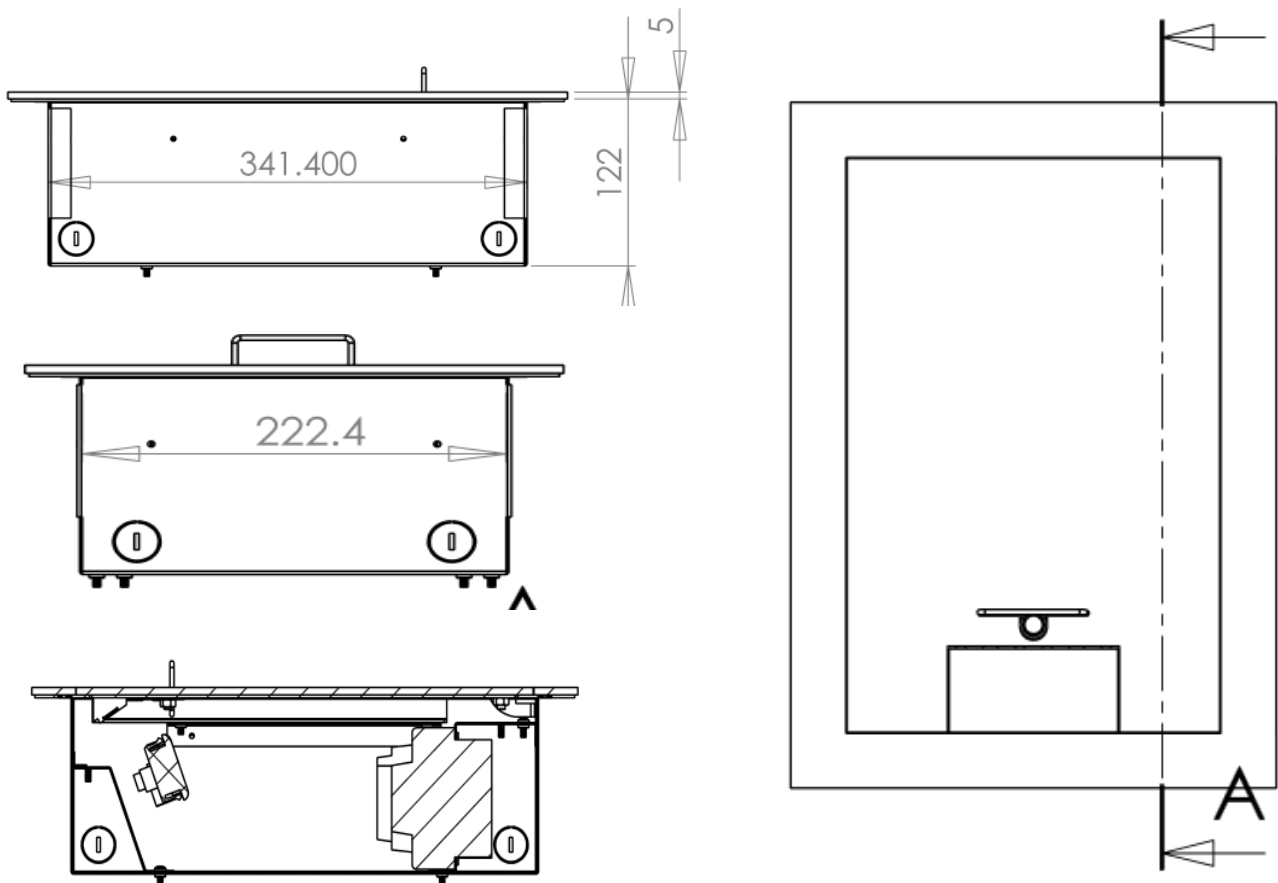

ITEM NO.	DESCRIPTION	QTY
1	3 PHASE STAINLESS STEEL LID - LARGE	1
2	3 PHASE SS 120MM LARGE UNDERCARRIAGE	1
3	PROVISIONS FOR 32AMP - NOT SUPPLIED BY CMS	1
4	PROVISIONS FOR POWER	1
Floorbox cut out dimensions: 345mm X 225mm		

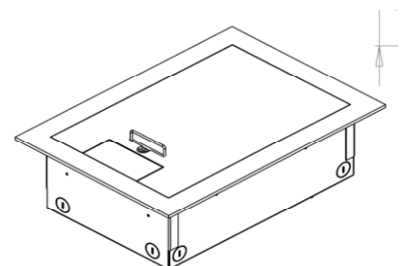

Floorbox: G1 Service Outlet

PART NO: G1

CMS Floor Service Outlet Stainless Steel - 2 Compartment

TECHNICAL SPECIFICATIONS:

CMS 2 Compartment - 77mm deep with stainless steel cover for surface mounting. Comes with removable dividers and has 25mm cable entry points. Designed for standard outlet provided by others (outlets shown for display purposes only, add to order). Powder coat finish available upon request.

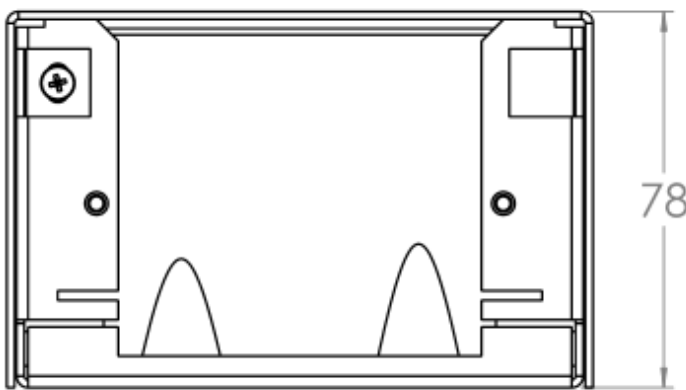

FRONT VIEW

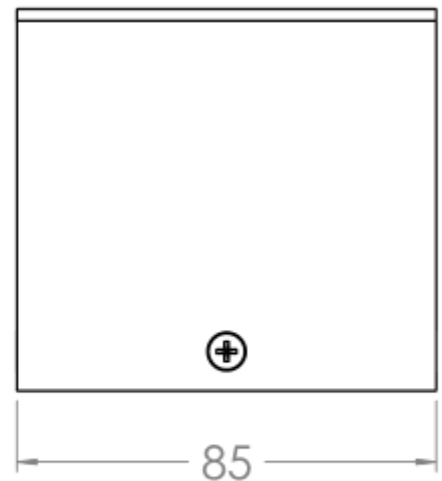

END VIEW

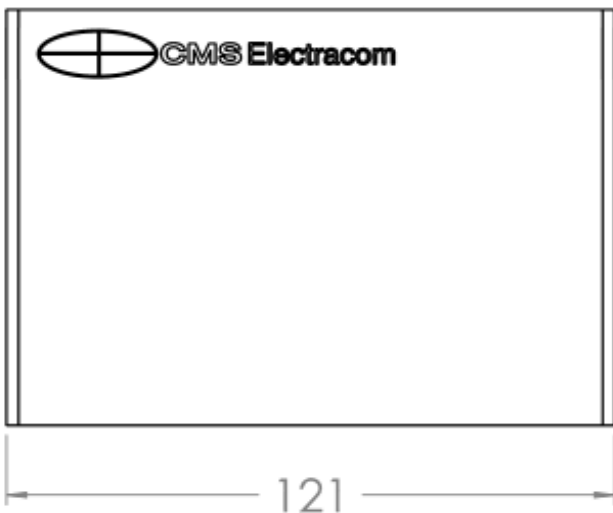

TOP VIEW

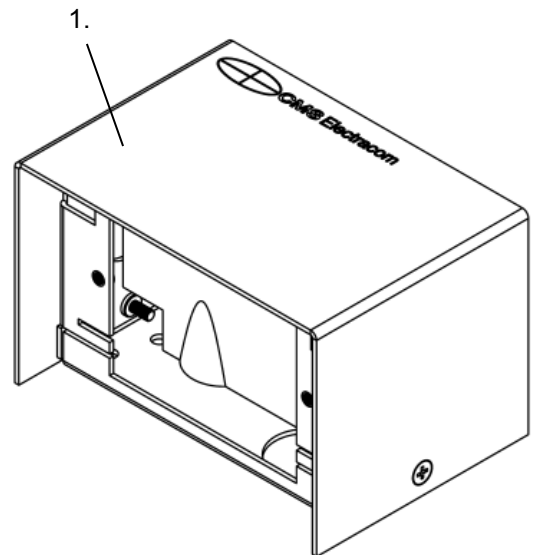

ITEM NO.	DESCRIPTION	QTY
1	STAINLESS STEEL COVER	1

G1Floorbox overall dimensions: 120mm x 85mm x 77mm

Floorbox: G2 Service Outlet Series

PART NO: G2

CMS Floor Service Outlet Stainless Steel - 4 Compartment

TECHNICAL SPECIFICATIONS:

CMS 4 Compartment - 77mm deep with stainless steel cover for surface mounting. Comes with removable dividers and has 25mm cable entry points. Designed for standard outlet provided by others (outlets shown for display purposes only). Powder coat finish available upon request.

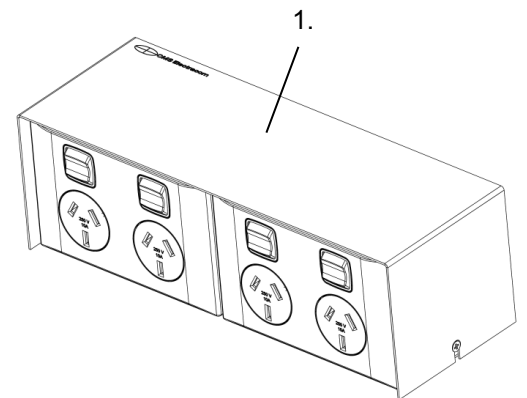
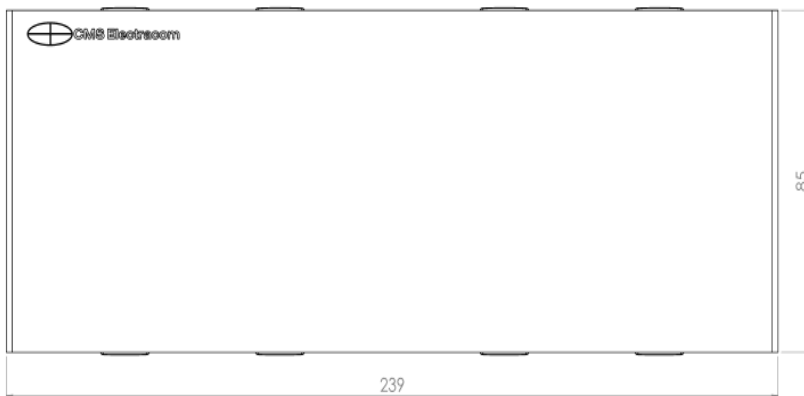
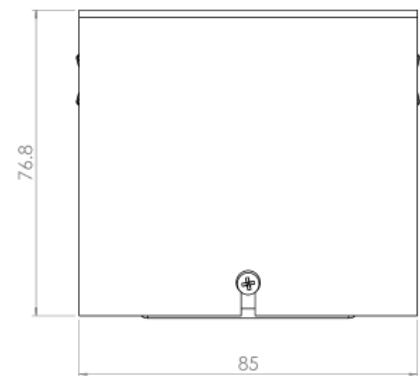
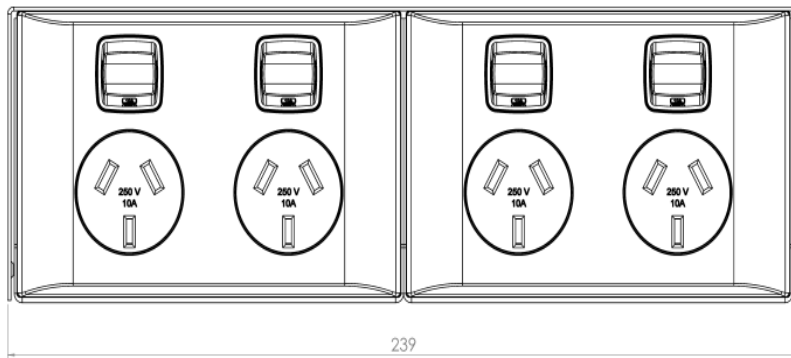

ITEM NO.	DESCRIPTION	QTY
1	STAINLESS STEEL COVER	1
G2 Floorbox overall dimensions: 240mm x 85mm x 77mm		

Floorbox: G1 Service Outlet

PART NO: G1 Mini

CMS Mini Floor Service Outlet Stainless Steel - 2 Compartment

TECHNICAL SPECIFICATIONS:

CMS 2 Compartment, 100mm deep with stainless steel cover for surface mounting. Complete with two single CMS 10amp GPOs. Powder coat finish available upon request.

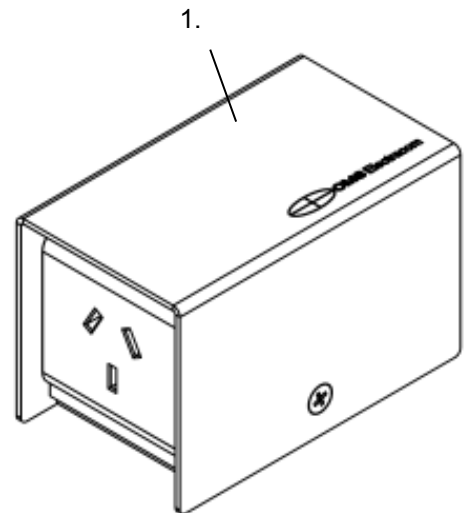
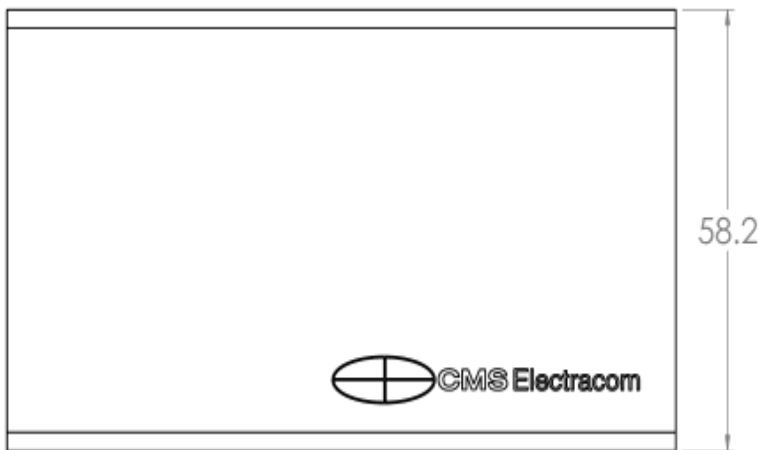
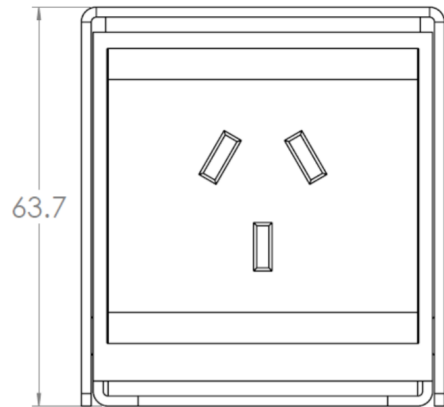
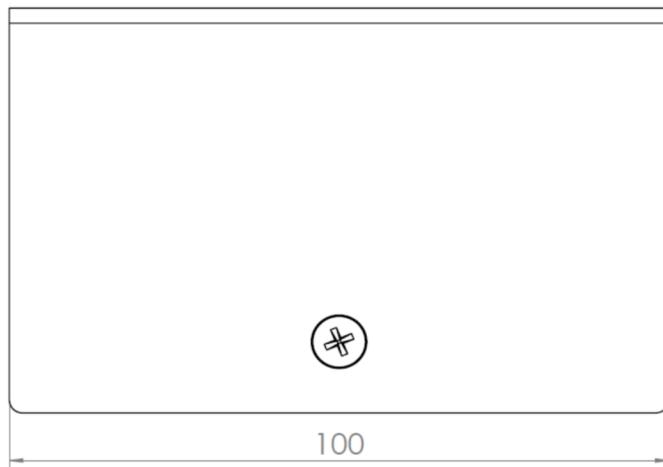

ITEM NO.	DESCRIPTION	QTY
1	STAINLESS STEEL COVER	1

G1 Mini Floorbox overall dimensions: 58mm x 64mm x 100mm

Floorbox: G1-56 Service Outlet Series

PART NO: G1-56

CMS Floor Service Outlet Stainless Steel 2 Compartment - 200deep

TECHNICAL SPECIFICATIONS:

CMS 2 Compartment, 200mm deep with stainless steel cover for surface mounting. Complete with provision for 56 series outlet. Powder coat finish available upon request.

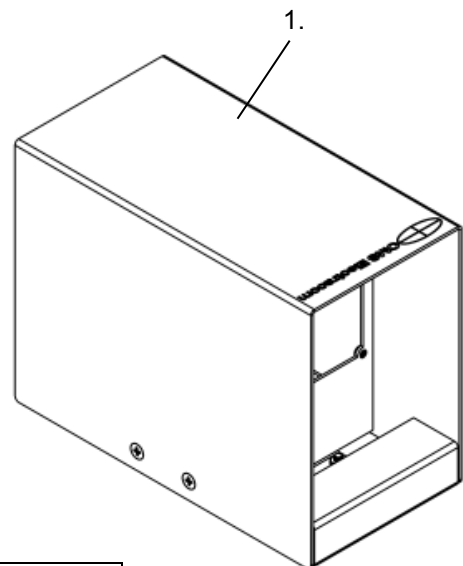
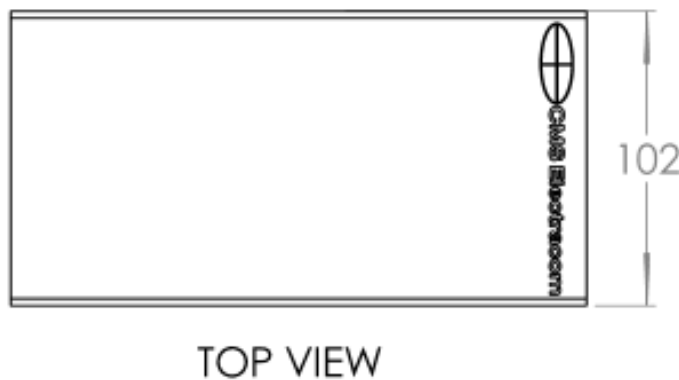
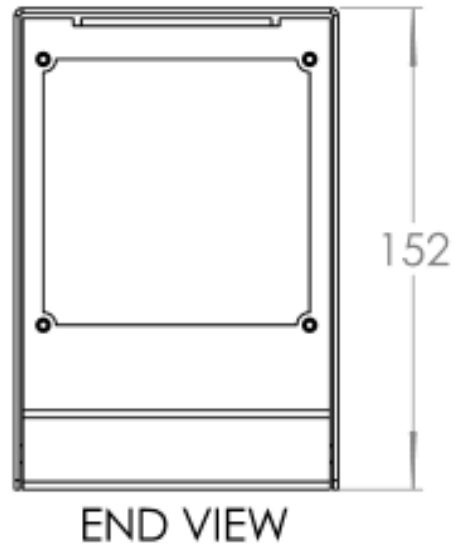
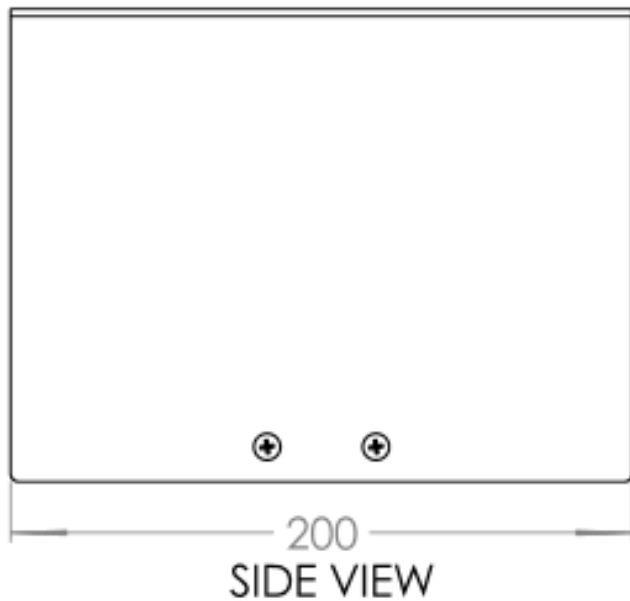

ITEM NO.	DESCRIPTION	QTY
1	STAINLESS STEEL COVER	1
2		1
G1-56 Floorbox overall dimensions: 100mm x 152mm x 200mm		

Floorbox: GES2 Series

PART NO: GES2

CMS Recessed Lid Floor Outlet - 2 Compartment, 70mm deep

TECHNICAL SPECIFICATIONS:

CMS 2 Compartment - 70mm deep recessed floorbox. 5mm recessed lid. Comes with easy to grab lifting handle and cable exit cap. The undercarriage is made from plated steel with 2 x 25mm multiple cable entry points. Lid available in Grey or Black. **Load Capacity: 200kg**

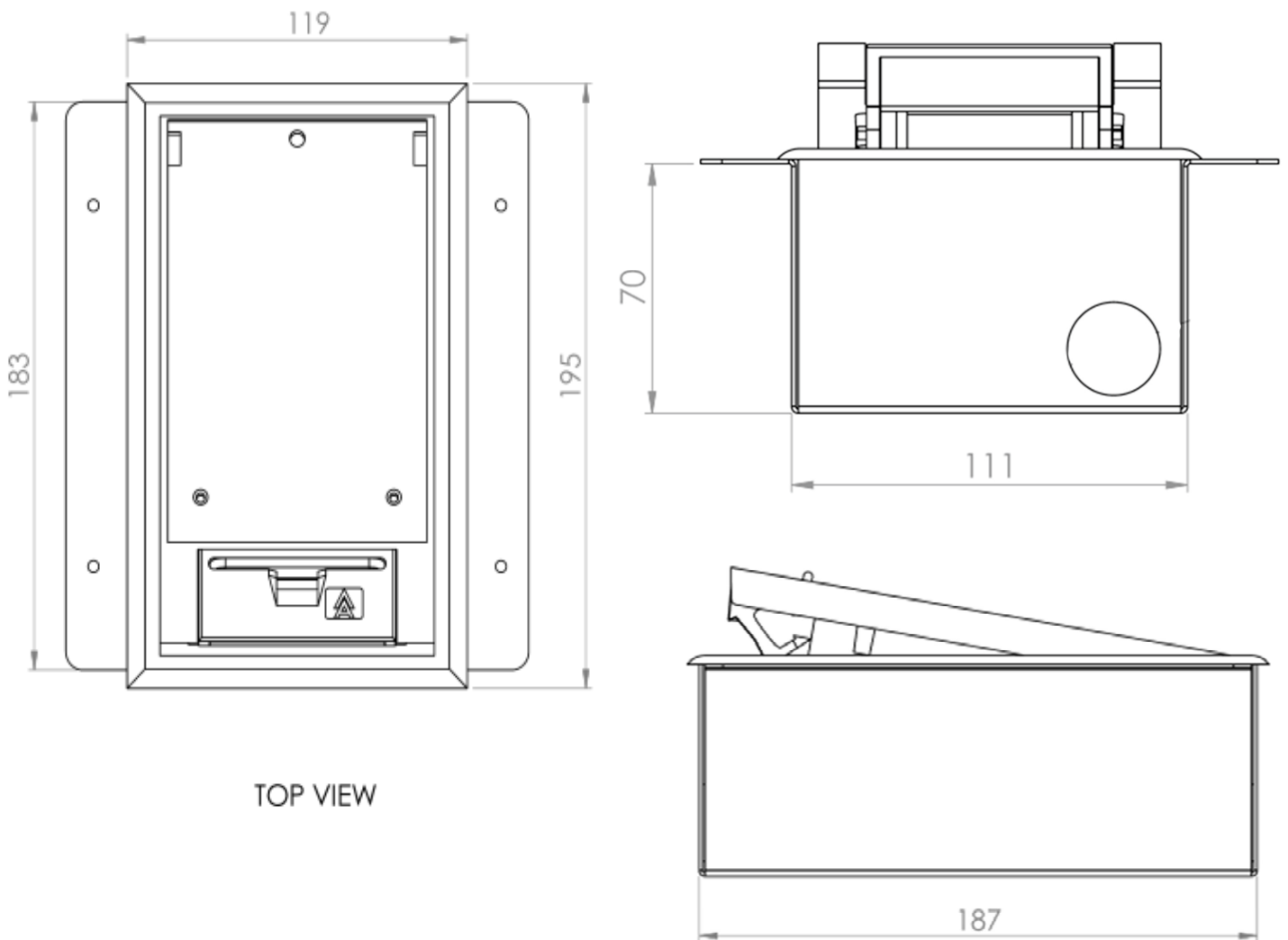

ITEM NO.	DESCRIPTION	QTY
1	RECESSED LID	1
2	PLATED STEEL 70MM UNDERCARRIAGE	1

Floorbox cut out dimensions: 188mm x 112mm x 70mm

Floorbox: GES2 Stainless Steel Series

PART NO: GES2SS

CMS Stainless Steel Butted Edge Lid Floor Outlet - 2 Compartment, 90mm deep

TECHNICAL SPECIFICATIONS:

CMS 2 Compartment - 90mm deep stainless steel butted edge lid floor box. Comes with easy to grab lifting handle and cable exit cap. The undercarriage is made from plated steel with 2 x 25mm multiple cable entry points. **Load Capacity: 210kg**

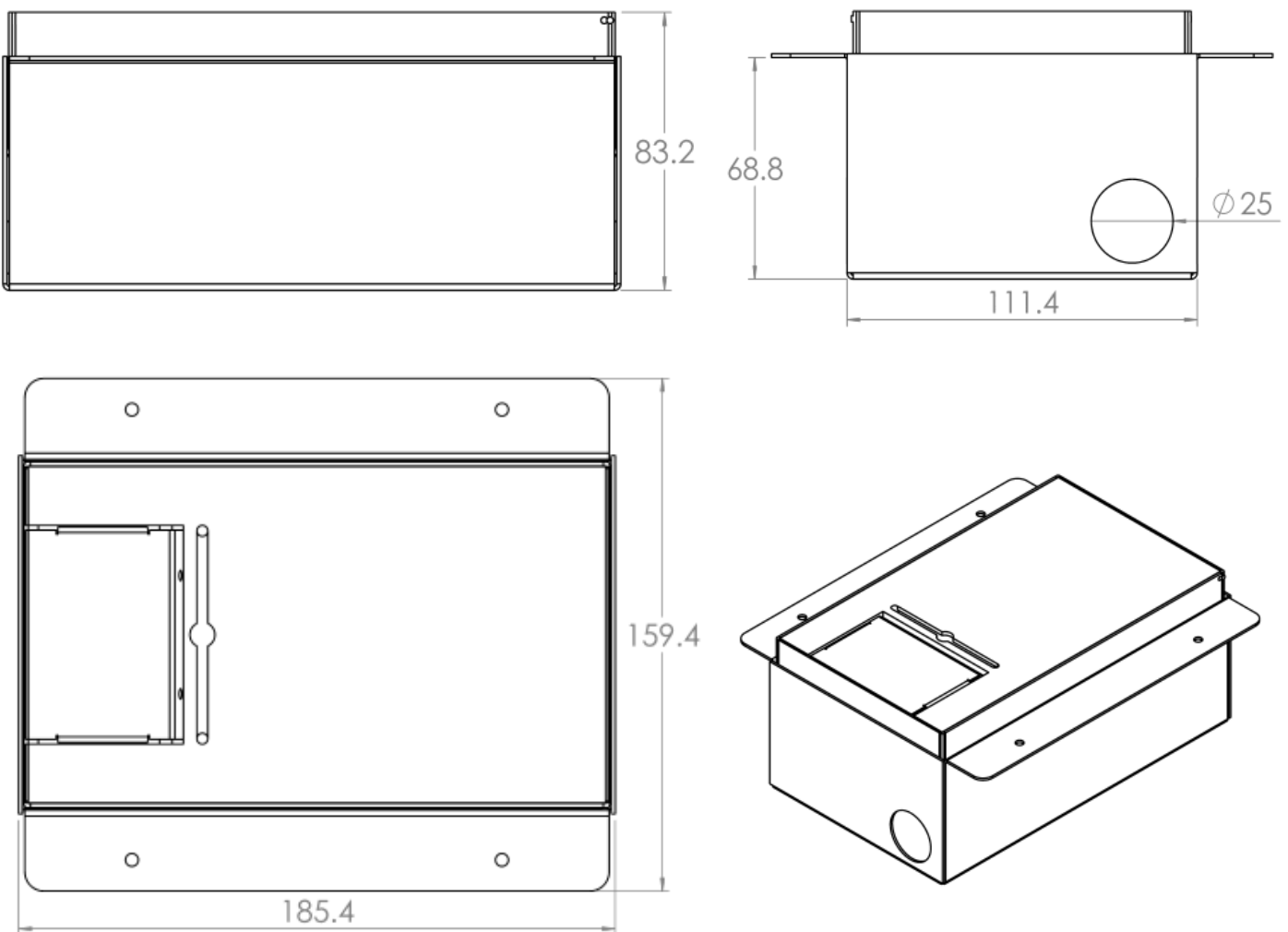

ITEM NO.	DESCRIPTION	QTY
1	STAINLESS STEEL BUTTED EDGE LID	1
2	PLATED STEEL 90MM UNDERCARRIAGE	1
Floorbox cut out dimensions: 188mm x 112mm x 90mm		

Floorbox: GESRM2 Series (IP65)

PART NO: GESRM2B/BE

IP65 Rated Floorbox With Butted Edge Lid - 100mm deep

TECHNICAL SPECIFICATIONS:

IP65 rated floorbox - 100mm deep, butted edge lid available in brass or nickel die cast. Box is IP65 protected when lid is closed. The undercarriage is made from 1.2mm galvanised steel. Can be fitted with one 10amp GPO and provision for two data/telephone.

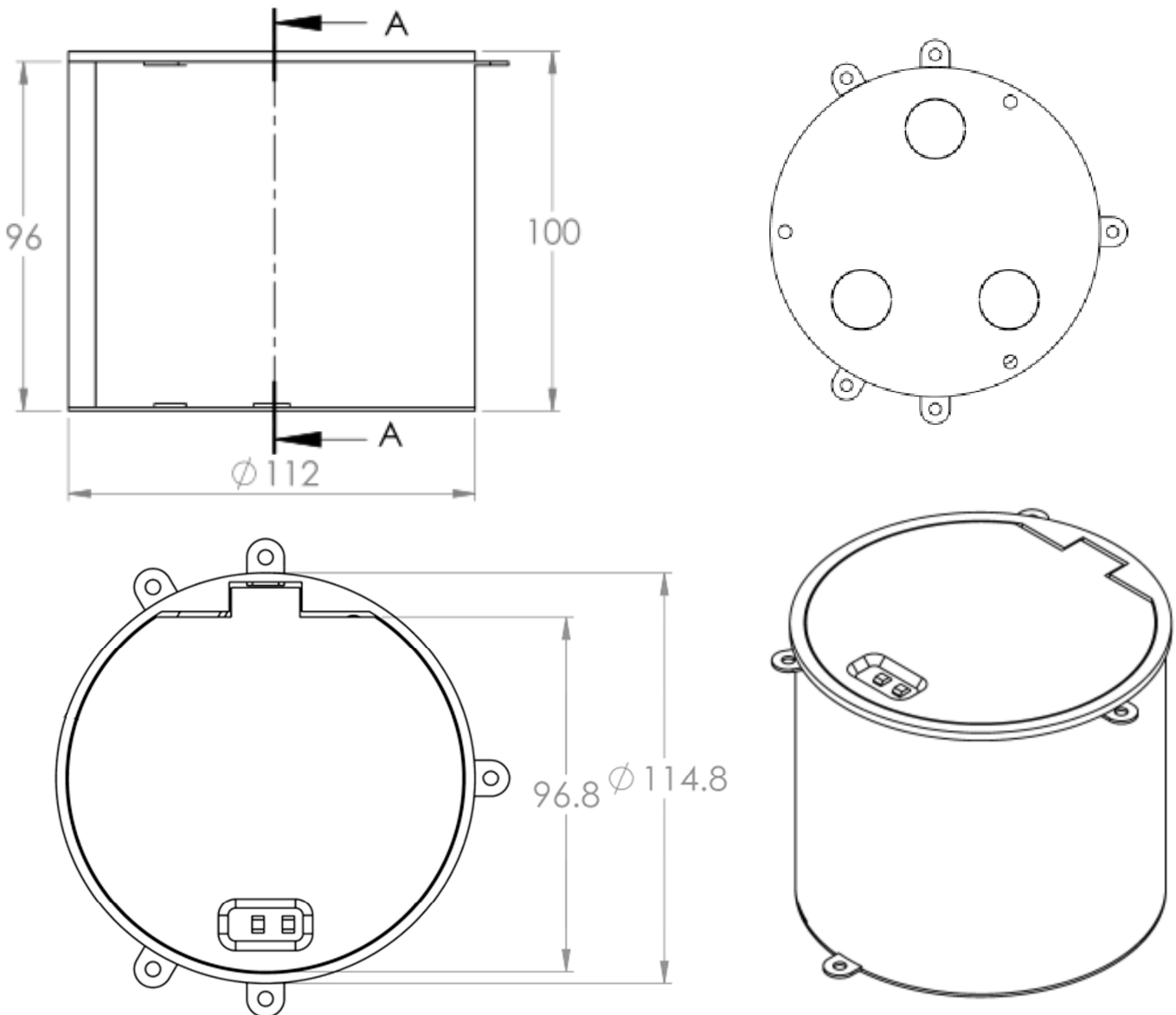

ITEM NO.	DESCRIPTION	QTY
1	BUTTED EDGE LID	1
2	GALVANISED STEEL 115MM UNDERCARRIAGE	1

Floorbox cut out dimensions: 115mm x 100mm

Floorbox: GESRM2 Series (IP65)

PART NO: GESRM2/CT

IP65 Rated Floorbox With Carpet Trim Lid - 100mm deep

TECHNICAL SPECIFICATIONS:

IP65 rated floorbox - 100mm deep, carpet trim lid available in brass or nickel die cast. Box is IP65 protected when lid is closed. The undercarriage is made from 1.2mm galvanised steel. Can be fitted with one RJ45 data / telephone outlet & one general purpose power outlet.

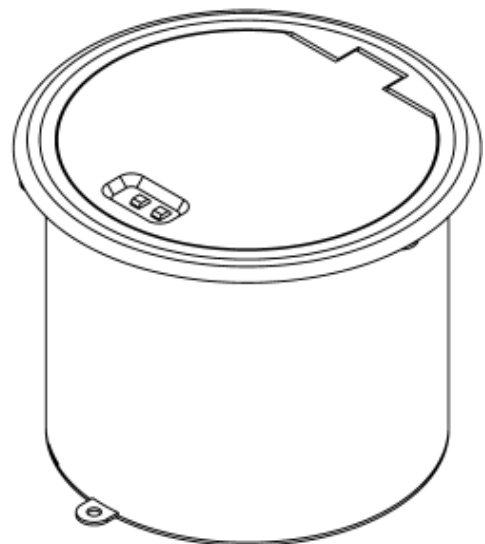
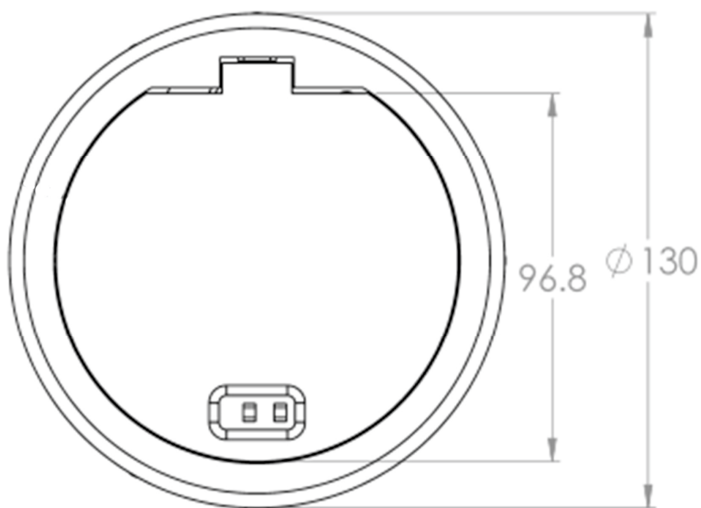
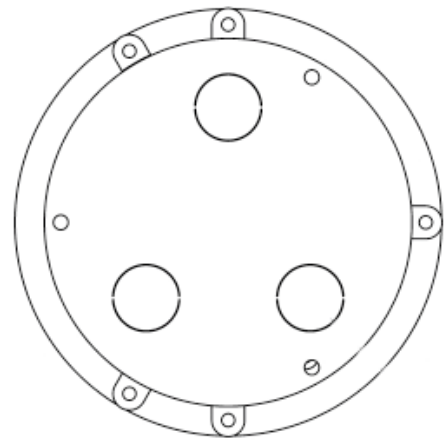
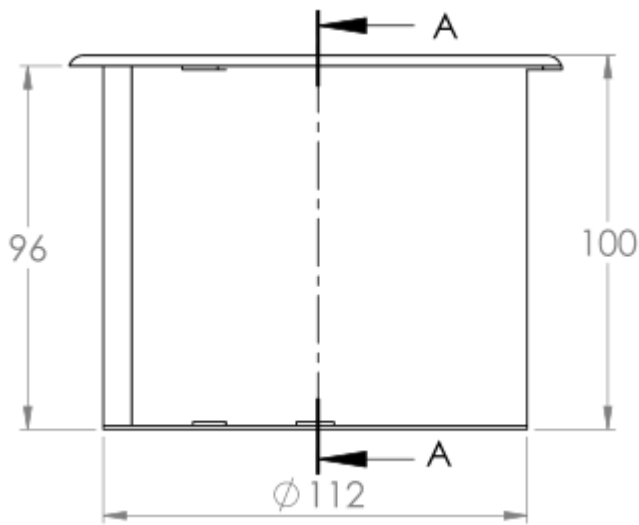

ITEM NO.	DESCRIPTION	QTY
1	CARPET TRIM LID	1
2	GALVANISED STEEL 115MM UNDERCARRIAGE	1

Floorbox cut out dimensions: 115mm x 100mm

Floorbox: Cablelink 1 Series

PART NO: CABLELINK 1

Single Application Floorbox With Dome Lid - 75mm deep

TECHNICAL SPECIFICATIONS:

Single application - 75mm deep, hinged fire retardant dome lid manufactured from Polyamide. Options of non-slip Nickel finish, non-slip brass and plastic flush floor lids are available for when the floor outlet is not in use

Body is zinc alloy die-cast with internal and external threads, with conduit mounting box for installation in a preformed concrete slab.

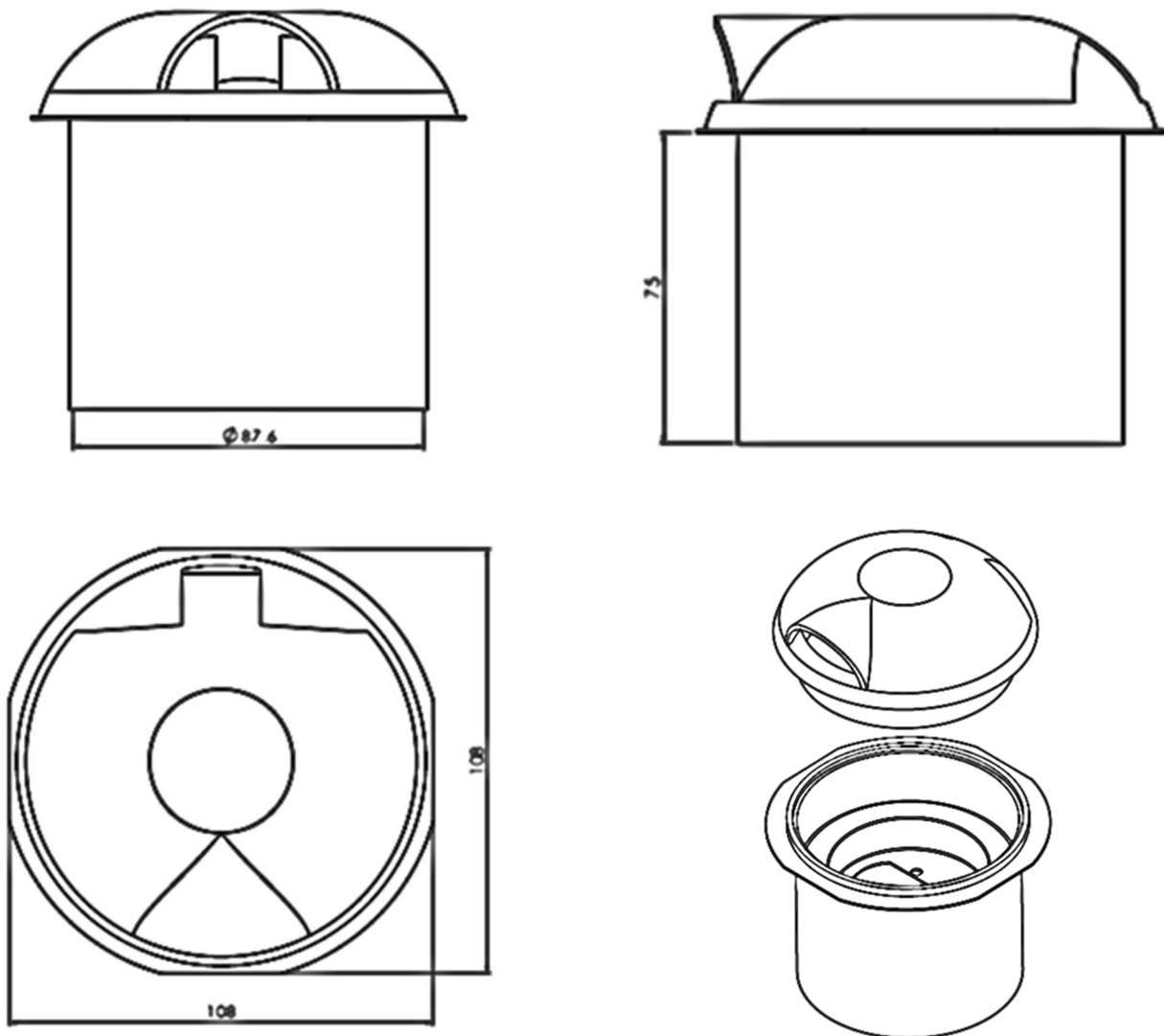

ITEM NO.	DESCRIPTION	QTY
1	HINGED DOME LID	1
2	ZINC ALLOY PRESSURE DIE-CAST BODY	1

Floorbox cut out dimensions: 92mm x 75mm

Floorbox: BR1 Series

PART NO: BR1

IP65 Rated Floorbox With Brass & Dome Lid - 95mm deep

TECHNICAL SPECIFICATIONS:

IP65 rated floorbox - 95mm deep, comes with dome. Box is IP65 protected when lid is closed. The undercarriage is made from 1.2mm galvanised steel. Can be fitted with one RJ45 data / telephone outlet & one general purpose power outlet.

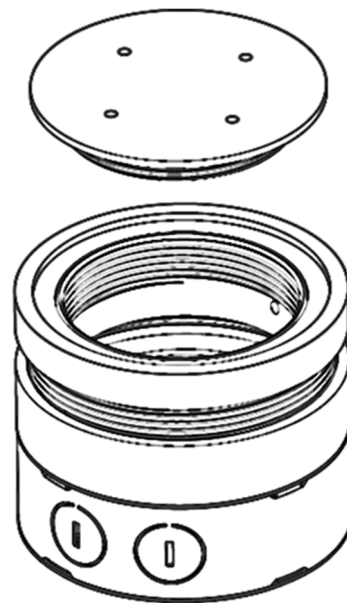
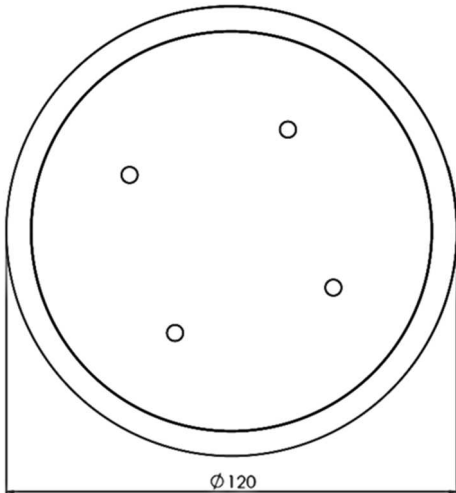
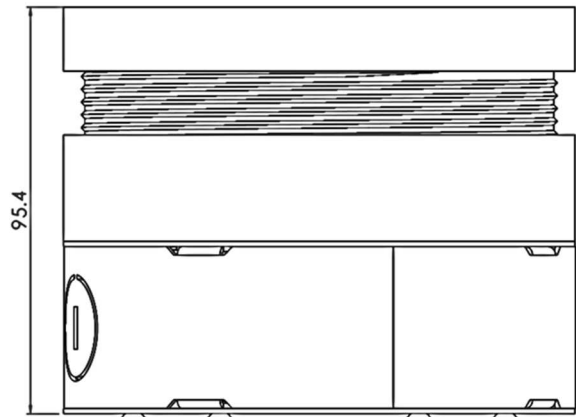
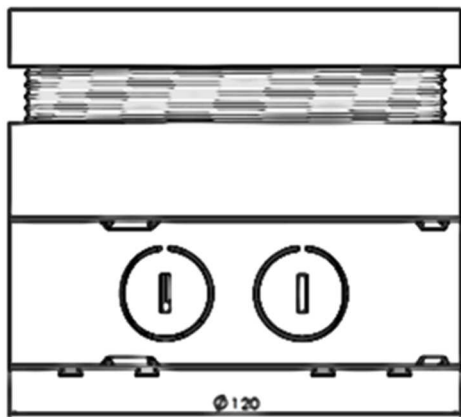

ITEM NO.	DESCRIPTION	QTY
1	HINGED DOME LID	1
2	ZINC ALLOY PRESSURE DIE-CAST BODY	1

Floorbox cut out dimensions: 92mm x 75mm



AUSTRALIA

1300 159 159

NEW ZEALAND

+64 9 582 0776

UNITED KINGDOM

+44 (0) 203 356 9709