

NOTE:

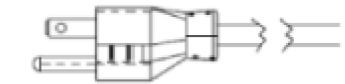

CABLE TYPE: 1.5MM
 PART NUMBER:
 DESCRIPTION: TYPE B PLUG TO FREE END LEAD
 LENGTH: 1800mm (72')

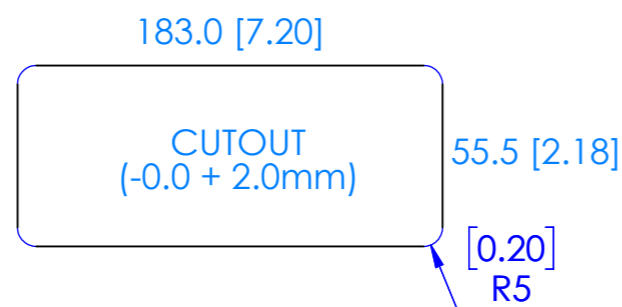
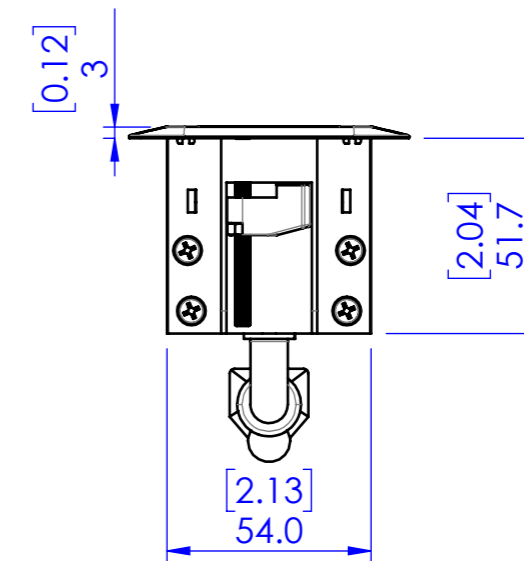
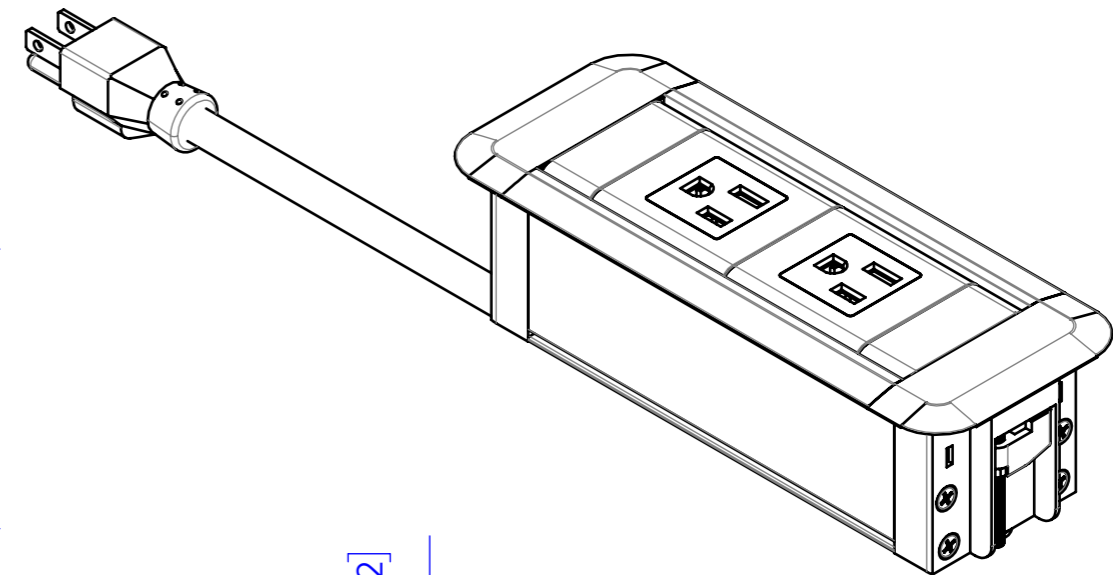
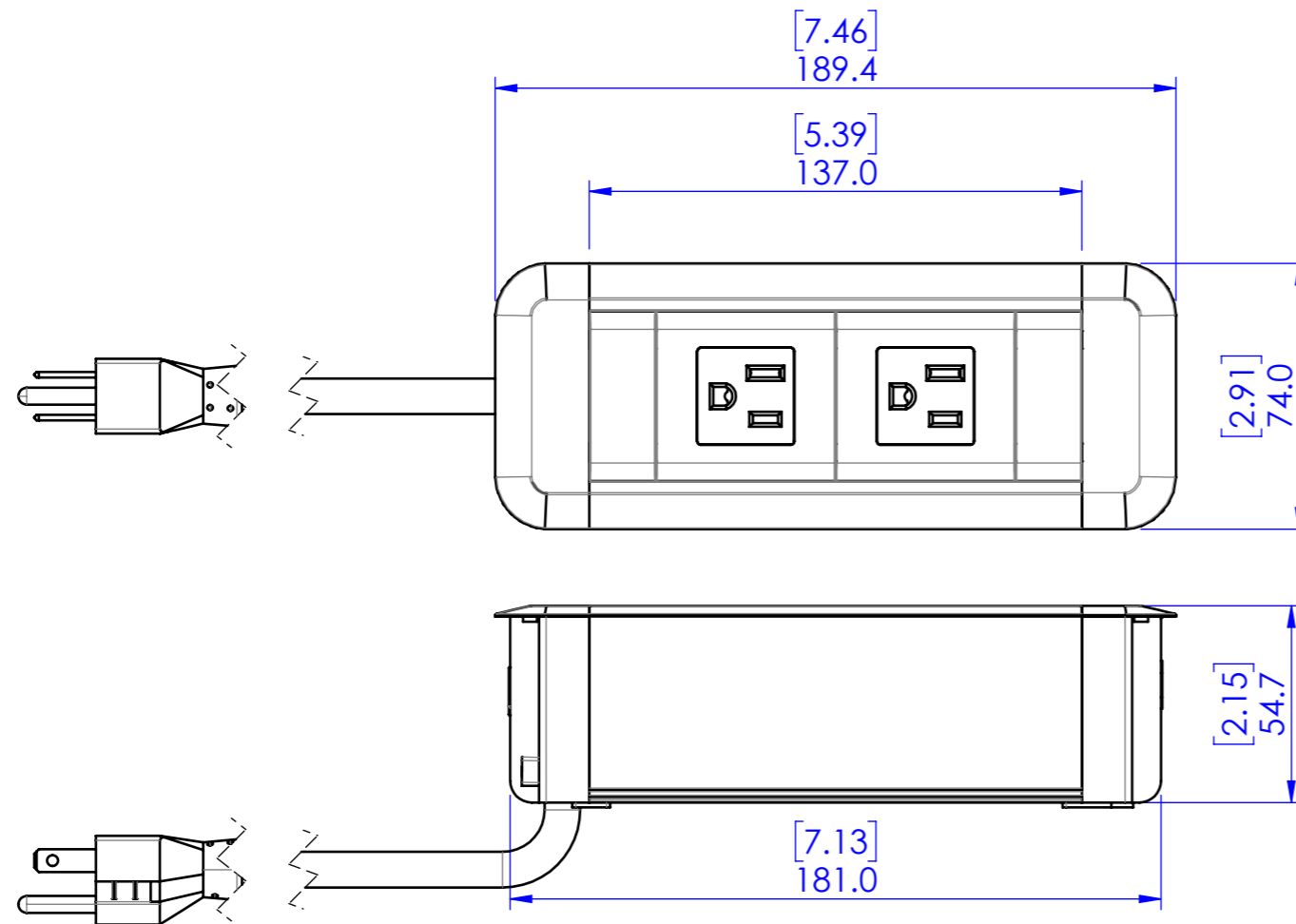

CUSTOMER SIGNATURE:	TOLERANCES UNLESS OTHERWISE STATED: X ±0.5 X.X ±0.2 X.XX ±0.1 X.XXX ±0.05 ANG ±0.5°
MATERIAL: PLASTIC / ALUMINIUM	
FINISH: FINE EDM / ANODISED	
COLOUR: WHITE / SILVER	
THIS DRAWING & ASSOCIATED CAD FILES ARE ISSUED IN THE STRICTEST CONFIDENCE AND ARE ONLY TO BE USED IN THE COMMERCIAL INTERESTS OF CMS ELECTRACOM PTY LTD	

DRAWN IN mm TO AS1100 DO NOT SCALE



TITLE: CENTRA WITH 2 US SOCKET		
DRAWING: LU28115	REV: 1	A3
SCALE 1:2	SHEET 1 OF 2	