

USE LU21933 WHEN INSTALLING GPO

FACTORY ONLY INSERTABLE MODULES
REFER PAGE 2 FOR
MODULE CONFIGURATION

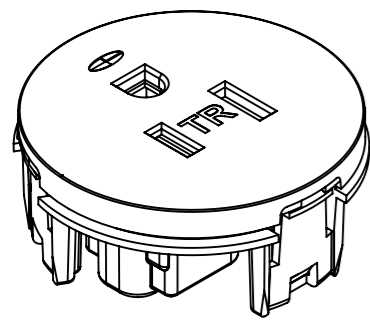

US SOCKET OUTLET = F

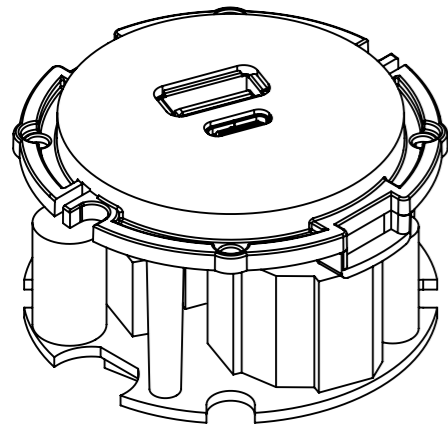
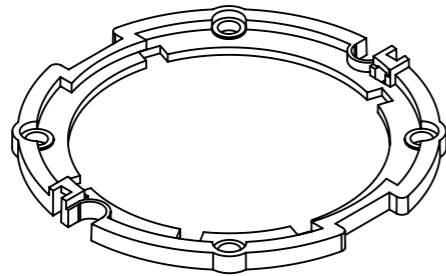

USB AC MODULE = U

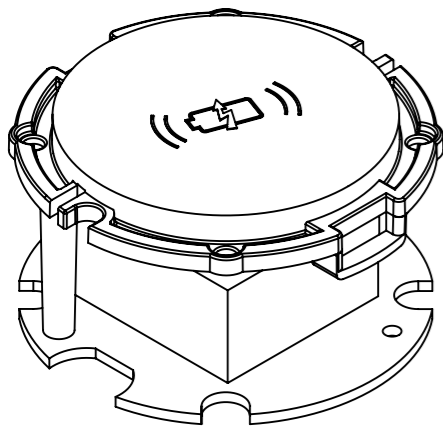

WIRELESS CHARGING MODULE = W

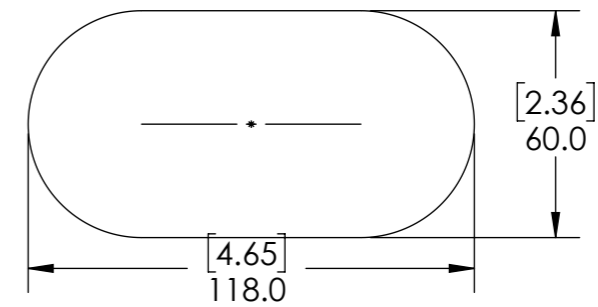
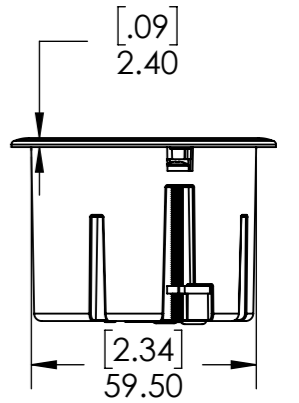
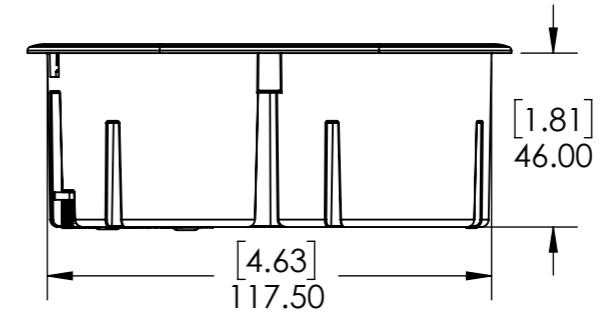
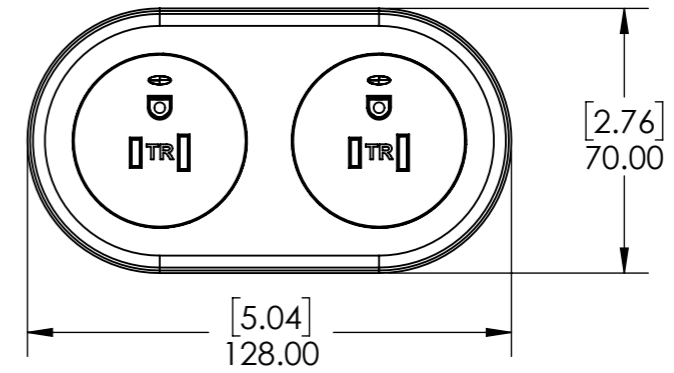
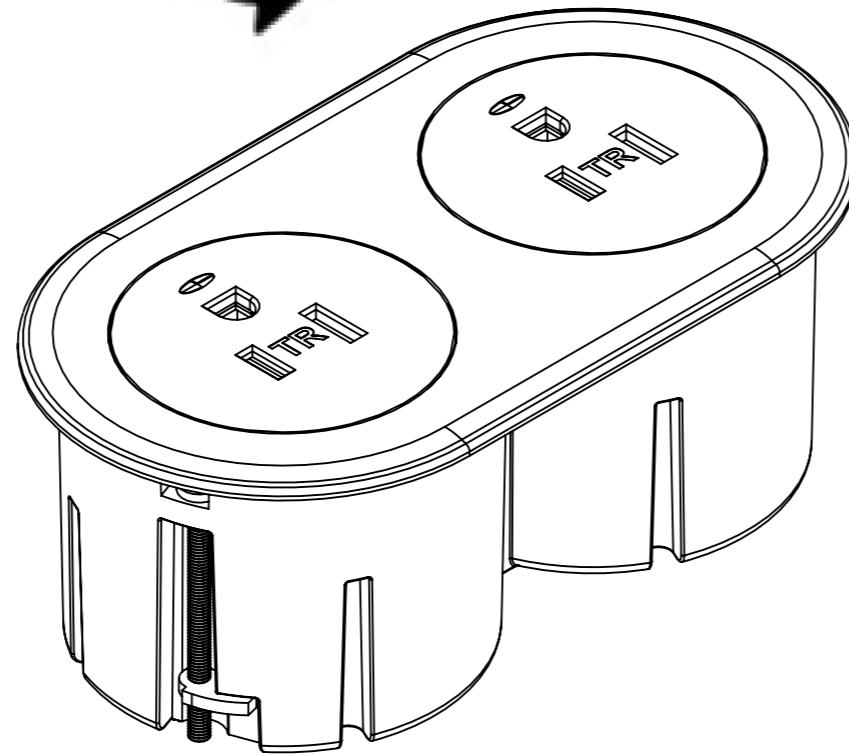

ROUTING CUTOUT
118mm x 60mm
-0/+1mm

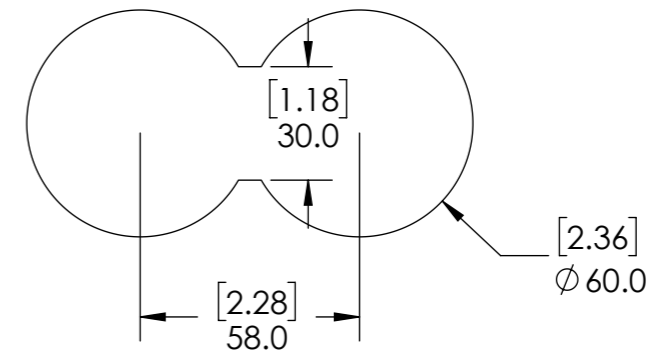

MANUAL HOLESAW
CUTOUT
2 off 60mm HOLES
58mm PITCH
CUT FLATS 30mm
-0/+1mm

REV	DESCRIPTION	DATE	DRWN	APPV
2	CHANGED TOLERANCE FROM 2mm TO 1mm	3/05/2023	GC	AP
1	RELEASED FOR PRODUCTION	2/09/2019	AP	
REVISIONS				

CUSTOMER SIGNATURE:
MATERIAL: PC FR
FINISH: TEXTURED
COLOUR: WHITE OR BLACK
THIS DRAWING & ASSOCIATED CAD FILES ARE ISSUED IN THE STRICTEST CONFIDENCE AND ARE ONLY TO BE USED IN THE COMMERCIAL INTERESTS OF CMS ELECTRACOM PTY LTD

TOLERANCES UNLESS OTHERWISE STATED:

X ±0.5
X.X ±0.2
X.XX ±0.1
X.XXX ±0.05
ANG ±0.5°

DRAWN IN mm TO AS1100 DO NOT SCALE



CMS Electracom COPYRIGHT © 2015

TITLE:

US MULTI 2 ECHO ASSEMBLY

DRAWING:

LU36246

REV:

2

A3

SCALE 1:2

SHEET 1 OF 4

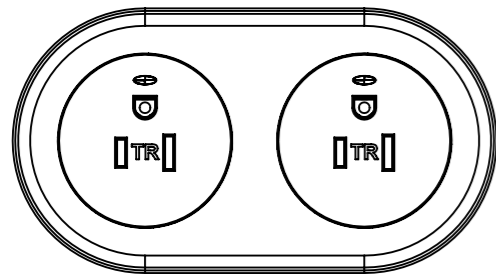

1EDH1H1Xxx

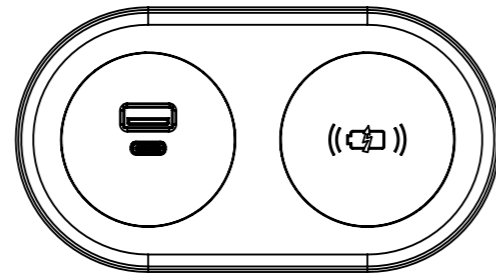

1EDU4WXxx

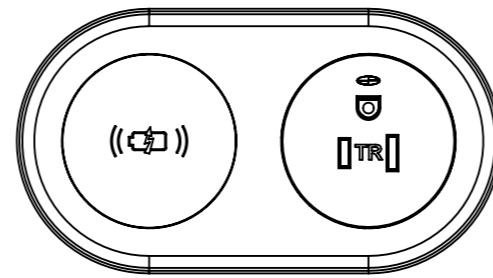

1EDWH1Xxx

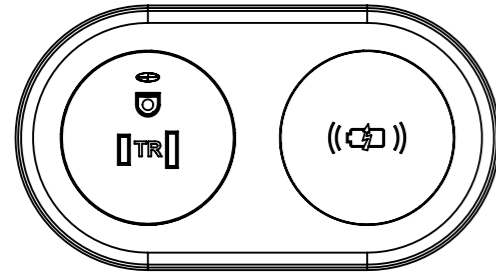

1EDH1WXxx

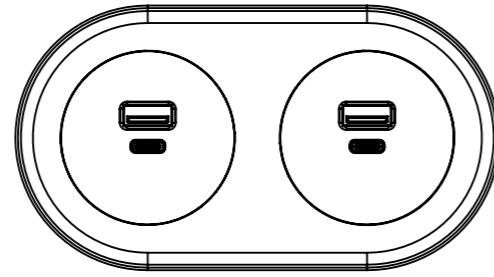

1EDU4U4Xxx

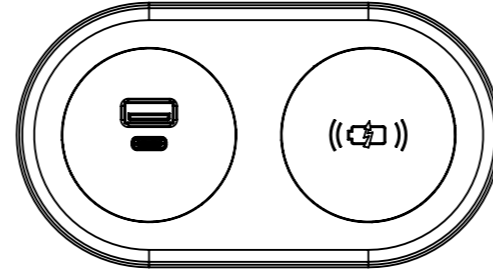

1EDU4WXxx

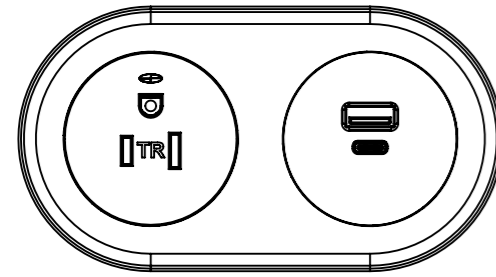

1EDH1U4Xxx

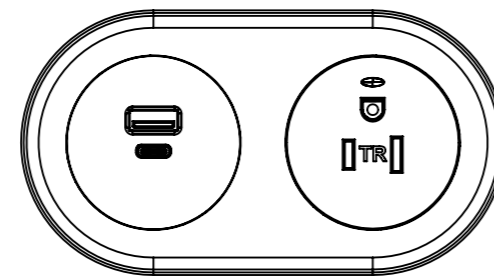

1EDU4H1Xxx

NOTE:

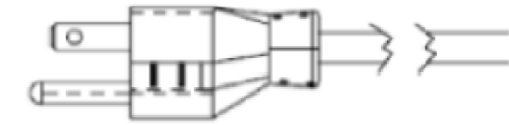



CABLE TYPE: 3 CORE x 2.08mm² (14AWG)
 DESCRIPTION: US PLUG LEAD
 COLOUR: WHITE OR BLACK
 (REFER TO PURCHASE ORDER)

x	LENGTH
A	1.5FT (457.2mm)
B	3.0FT (914.4mm)
C	4.0FT (1219.2mm)
D	5.0FT (1524mm)
E	6.0FT (1828.8mm)
F	8.0FT (2438.4mm)
G	10.0FT (3048mm)
H	12.0FT (3657.6mm)
I	15.0FT (4572mm)
J	18.0FT (5486.4mm)
K	21.0FT (6400.8mm)
L	24.0FT (7315.2mm)

PART NUMBER: 1EDH1H1Xxx

NOTE - X - LENGTH
 XX - COLOUR - WT / BK

CUSTOMER SIGNATURE:	TOLERANCES UNLESS OTHERWISE STATED: X ±0.5 X.X ±0.2 X.XX ±0.1 X.XXX ±0.05 ANG ±0.5°	 CMS Electracom <small>COPYRIGHT © 2015</small>		
MATERIAL: PC FR		TITLE: US MULTI 2 ECHO ASSEMBLY		
FINISH: TEXTURED		DRAWING: LU36246	REV: 2	A3
COLOUR: WHITE OR BLACK		SCALE 1:2		
<small>THIS DRAWING & ASSOCIATED CAD FILES ARE ISSUED IN THE STRICTEST CONFIDENCE AND ARE ONLY TO BE USED IN THE COMMERCIAL INTERESTS OF CMS ELECTRACOM PTY LTD</small>		<small>DRAWN IN mm TO AS1100 DO NOT SCALE</small> 		
		SHEET 2 OF 4		