

**FREEDOM SERIES FR210PB, FR210CS,
FR210DS & FR210I USER MANUAL**

IMPORTANT SAFETY INSTRUCTIONS



WARNING

This symbol indicates information concerning your personal safety.



CAUTION

This symbol indicates information on how to avoid damaging the unit.



IMPORTANT

This symbol indicates tips and information about FR210PB, FR210DS, FR210CS Operation.



CAUTION / WARNING



- Read all instructions before using the product.
- To reduce risk of injury, close supervision is necessary when the product is used near children.
- Use of an attachment not recommended or sold by power bank manufacturer may result in a risk of fire, electric shock, or injury to persons.
- To reduce risk of damage to the electric plug and cord, pull the plug rather than the cord when disconnecting power pack.
- Do not operate the unit with a damaged cord or plug, or a damaged output cable.
- Do not use if the unit has been damaged or modified. Damaged or modified batteries may exhibit unpredictable behaviour resulting in fire, explosion or risk of injury.
- Do not disassemble FR210PB, FR210CS, FR210DS, take it to a qualified service person when a service or repair is required. Incorrect assembly may result in a risk of fire or electric shock.
- Do not expose to water.
- This unit may become hot when recharging, handle with care.
- Do not leave in hot conditions 35°C or above e.g., left sitting in hot car, left sitting in direct sunlight.
- Do not operate unit outside of specified conditions.
- This unit contains Li-ion 18650 or equivalent cells.
- Do not expose to heat or throw in fire.
- Do not attempt to modify.
- Be careful when unpacking the unit. Do not use sharp objects when removing the packaging as this may cause scratches to the unit.
- The socket-outlet shall be installed near the equipment and shall be easily accessible.

SAVE THESE INSTRUCTIONS

Contents

Product Specifications.....	3, 4
Product Overview	
FR210PB.....	4
FR210CS.....	5
FR210DS.....	5
FR210I.....	6
Setting up FR210CS.....	
Using FR210CS.....	7
Setting up FR210DS.....	
Using FR210DS.....	8, 9
Setting up FR210I.....	
	9, 11
Using FR210PB.....	
	10, 11
User Maintenance Instructions.....	
	11
User Do's & Don'ts.....	
	12
Moving and Storage Instructions	
	12
Disposal of Product.....	
	13
Trouble Shooting.....	
	14, 15, 16
FR210DS Wiring Examples.....	
	17, 18, 19
FR210 Estimated Run Times.....	
	20

Specification FR210PB

(Power Bank)

Model: FR210PB

Battery cells: Li-ion 18650

Battery Capacity: 21.6V, 9540mAh*(206Wh)(+/- 5%)

12pin Input (battery pack voltage):
18~25.2V (constant power 150W) via
Charging Station (FR210CS), 18~25.2V
(constant power 100W) via Docking Station
(FR210DS)

12pin output (battery pack voltage): 18~25.2V,
16~19A (1 x FR210PB for Docking Station
output). 18~25.2V, 25.2A max (2 x FR210PB
for Docking Station output)

Type-C output: DC 5V/3A, 9V/3A, 12V/3A
15V/3A, 20V/5A (PD3.0 100W)

Type-A output: DC 5V/3A, 9V/2A, 12V/1.5A
(QC3.0 18W)

Total output: 118W (Both ports combined)

Dimensions: 251.8mm (L) x 151.4mm (W) x
38.1mm (H)

Weight: 1.53KG

Operation Temperature: 5~35°C

Packaging Content: 1 x FR210PB (Release
Key included with FR210PBK variant)

Specification FR210CS

(Charging Station)

Model: FR210CS

Power Input: 20V/7.6A

Power output: 18~25.2V (constant power
150W)

Dimensions: 326.4mm (L) x 199.3mm (W) x
92mm (H)

Weight: 1.88KG

Operation Temperature: 5~35°C

Power Supply: GVE AC/DC Adaptor

Model: GM152-2000760-F

Input: 100-240V~ 50/60Hz 2.5A

Output: 20V DC 7.6A

Packaging content: 1 x FR210CS, 1 x AC Power Cord, 1 x Power Supply (20V/7.6A)

Specification FR210DS

(Docking Station)

Model: FR210DS

12pin Input: 18~25.2V, 25.1A max (2 x FR210PB docked or more)

Power Input: DC Jack 20V/5A, USB C 20V/3A

Type-C output: DC 5V/3A, 9V/3A, 12V/3A, 15V/3A, 20V/5A (PD3.0 100W)

Type-A output: DC 5V/3A, 9V/2A, 12V/1.5A (QC3.0 18W)

DC OUT 1: (XT60 connector) 18-25.2V (Cell voltage) 16-19A

DC OUT 2: (XT60 connector) 12V, 18V, 20V, 24V/11A

Total output: 300W combined (350W DC OUT 1 for 1 – 2 minutes at a time)

Dimensions: 280.5mm (L) x 152.2mm (W) x 31.6mm (H)

Weight: 0.92KG

Operation Temperature: 5~35°C

Packaging content: 1 x FR210DS

Specification FR210I

(Inverter)

Model: FR210I/REP500

Power Input: 18V-25V DC via XT60

Power Output: 240V AC 300W via TAG Panel Mount Connector

Dimensions: 244mm (L) x 112mm (W) x 60mm (H)

Weight: 1.12KG

Operation Temperature: 5~35°C

Packaging content: 1 x FR210I

Product Overview – FR210PB

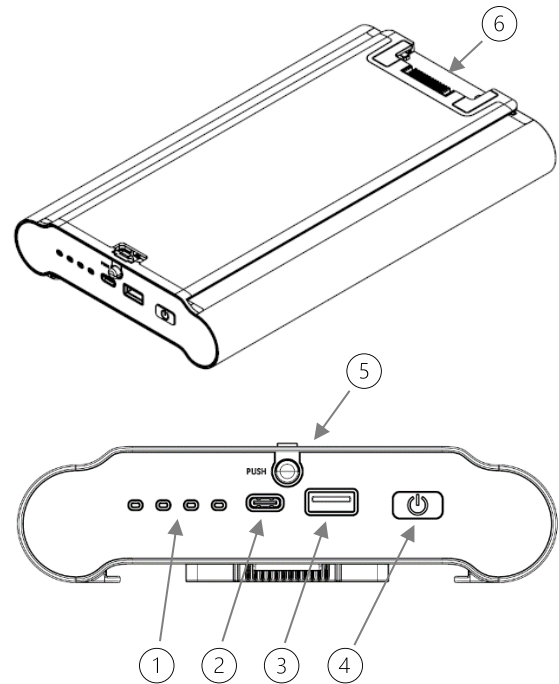

- ① LED Charge level indicator
- ② USB C Port
- ③ USB A Port
- ④ Power Button
- ⑤ Push Button Release (For Model FR210PBP)

(Key version depicted below) (For Model FR210PBK)

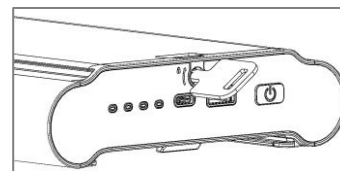

- ⑥ 12pin connector

Product Overview – FR210CS

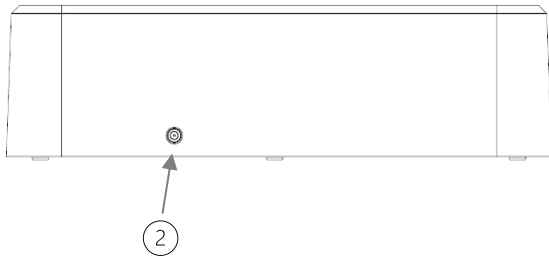
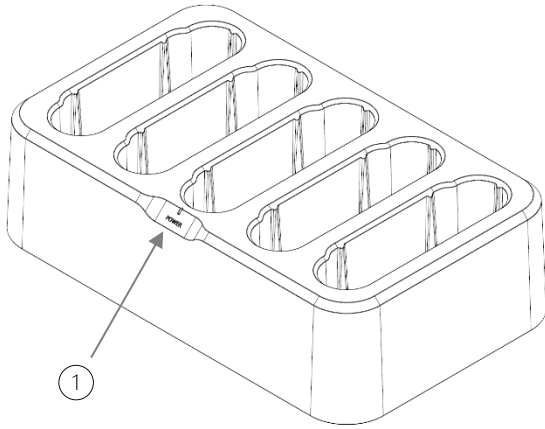

- ① Power Indicator
- ② D.C. Jack – Power In (20V/7.6A)
- ③ Optional fixing brackets available (depicted below)

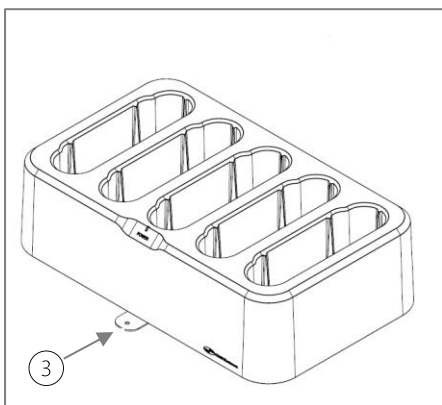

Product Overview – FR210DS

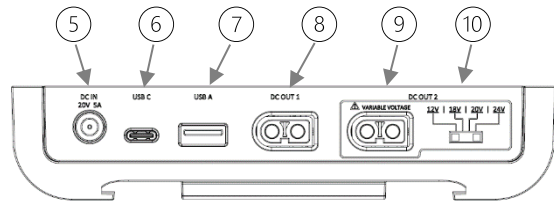
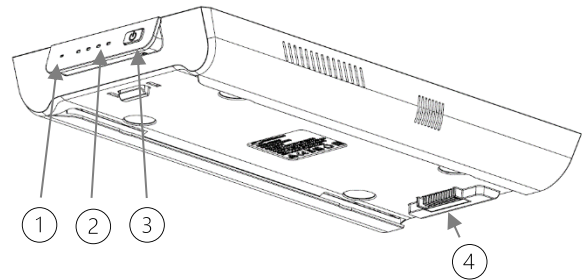

- ① Overload Indication (Red)
- ② Charge level Indication
- ③ Power Button
- ④ 12pin connector
- ⑤ DC IN 20V/5A
- ⑥ USB C Port
- ⑦ USB A Port
- ⑧ DC Out 1
- ⑨ DC Out 2 (Variable Voltage)
- ⑩ Voltage Selector Switch

Product Overview – FR210I

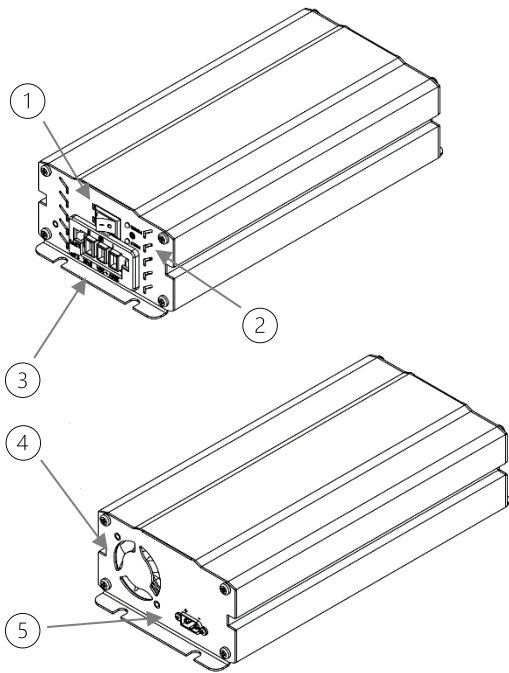

- ① Power Switch
- ② Power (Green)/Fault (Red) LED indication
- ③ 240V AC OUT via TAG connector
- ④ Exhaust Fan
- ⑤ DC IN via XT60 Panel mount connector

1. Plug the AC cord into the power supply.
2. Plug the AC plug into an outlet.
3. Plug the power out lead from the power supply into the DC jack on at the back of FR2CS. Power indicator will illuminate green.



IMPORTANT – Fixing Bracket Setup

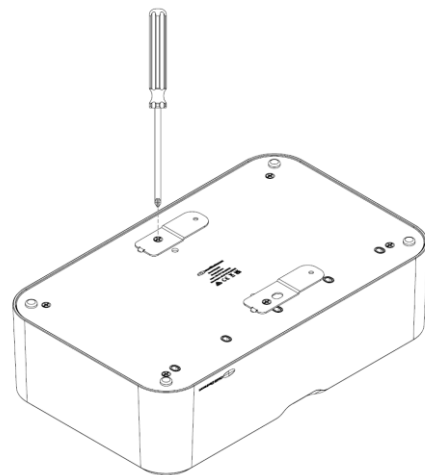

1. When first unboxing the Charging Station (FR210CS), the fixing brackets will be secured in the folded in position. Loosen the screw that secures the fixing bracket in place. Note that the screw will need to be lose/removed so that the small metal tab on the fixing bracket is able to clear the hole that's securing it in place.

Setting Up FR210CS



IMPORTANT

Setting Up

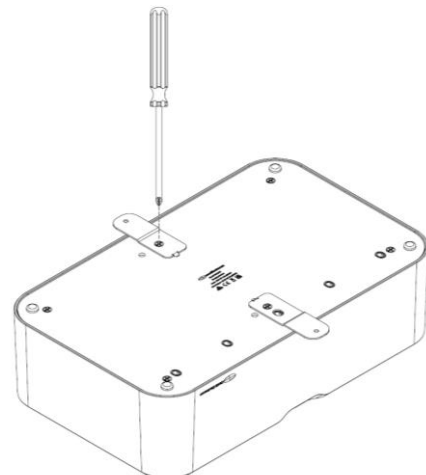
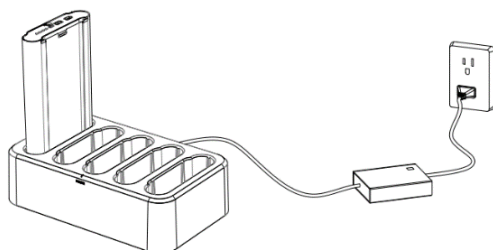

2. Rotate the fixing bracket outwards, the small metal tab on the bracket will align/fix into the outward position hole. This secures that fixing bracket so that it won't rotate once screwed into place.

Below image shows the metal tab of the fixing bracket locked into outward position. When packing the Charging station (FR210CS) away reverse this process.

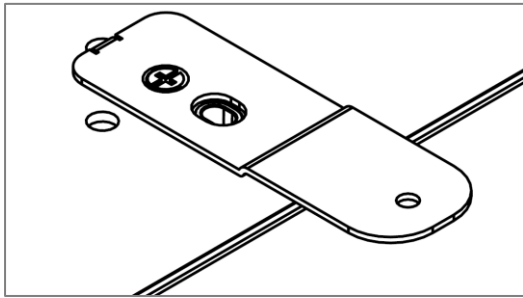

via the 12pin connector the end of each unit. The Charging Station can hold and charge up to five power banks (FR210PB) simultaneously.

Refer to the below table for charging times in relation to number of units charging.

5 Units	3 Units	1 Unit
9-10 Hours	6-7 hours	2-3 hours

☀ ☀ ☀ ☀	100%
☀ ☀ ☀ ☀	76% - 99%
● ☀ ☀ ☀	51% - 75%
● ● ☀ ☀	26% - 50%
● ● ● ☀	1% - 25%

☀ ..FLASH ☀ ..ON ● ..OFF

Using FR210CS

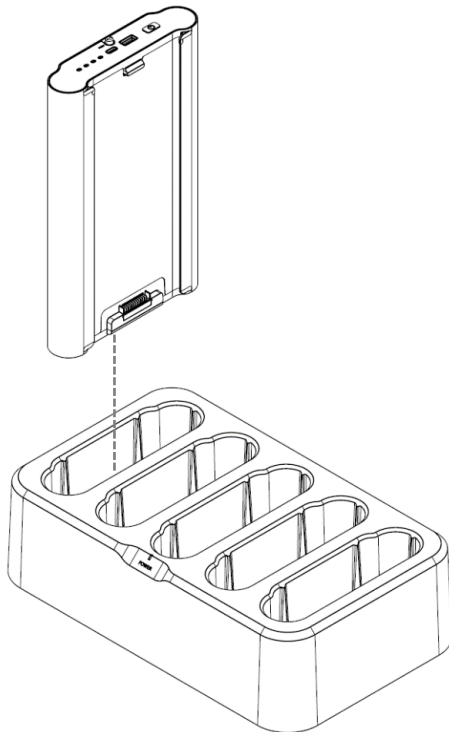

A white LED will flash to indicate the power bank is recharging. As the unit charges the additional LED(s) will remain ON until all four LEDs are ON constantly.

To recharge the power bank (FR210PB), place it into the dedicated charging station (FR210CS). The power bank will be recharged

Setting Up FR210DS



IMPORTANT

Setting up

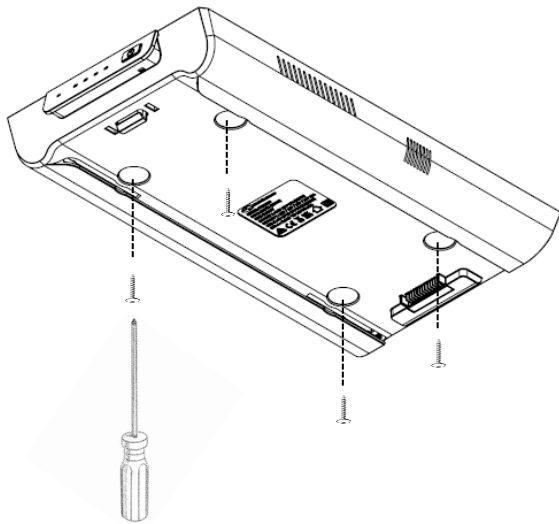

1. Position and screw the Docking Station (FR210DS) into place on the underside of the workstation using 4qty 6G screws (up to 8G will fit). There are 4 screw fixing locations on the underside of the Docking Station.

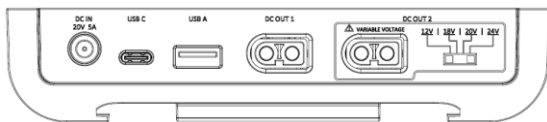

2. Connect compatible CMS products to the output ports on the rear of the unit.



CAUTION

If you are using DC OUT 2 make sure the correct voltage is selected before plugging in compatible devices.



IMPORTANT

Please refer to pages 17, 18 & 19 for details on how to connect compatible CMS products using our XT60 & Tag soft wiring system.

Using FR210DS

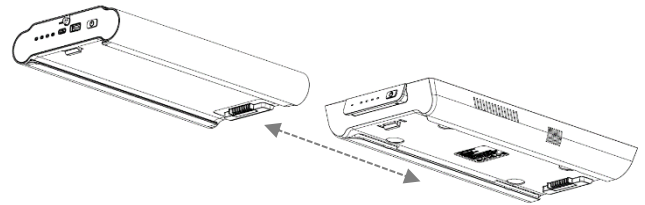

Slide the Power Bank (FR210PB) into the Docking Station (FR210DS) as shown. You will hear an audible clicking sound when locked in. The power button on the docking station may need to be pressed to power on the unit. All 4 LED's will illuminate when ON to display combined charge level of all docked power banks.



IMPORTANT

The front ports of the Power Bank will be disabled when docked in a docking station.

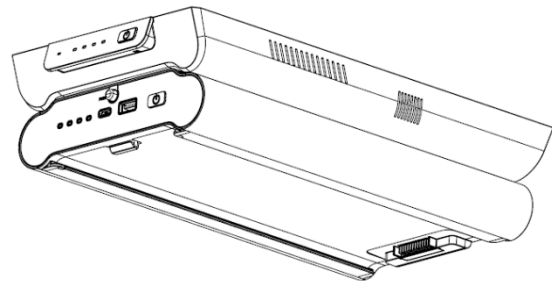

Multiple Power Banks (Up to 4 Max) can be stacked to increase runtime as shown below.

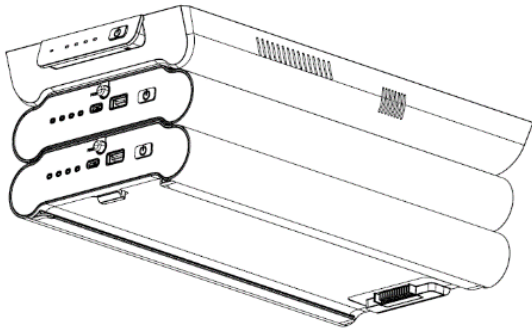

To disengage Power Bank(s) either press the push button release at the front of the unit you wish to disengage or use the key and turn in a clockwise direction. When released the Power Bank will spring out/forward slightly. Note some force may be required when pressing push release button in.



IMPORTANT - Maximum Outputs

The maximum available output of FR210DS with 1 Power Bank (FR210PB) docked is 150W between all output ports. NOTE if USB C is used then BOTH DC OUT ports will be deactivated due to limited available power. If no USB C in use then 150W total is available between both DC OUT ports. Maximum output is increased to 300W with 2 or more Power Banks (FR210PB) docked (350W for 1-2 minutes at a time to operate sit to stand desk).

As FR210DS operates each LED will go out systematically until the docked power bank(s) are depleted.

☀ ☀ ☀ ☀	100% - 75%
● ☀ ☀ ☀	74% - 50%
● ● ☀ ☀	49% - 25%
● ● ● ☀	24% - 1%
● ● ● ☀	1 - 0%

☀ ..FLASH ☀ ..ON ● ..OFF

The docking station (FR210DS) is capable of recharging the docked power bank(s)

(FR210PB) via the 20V/7.5A DC IN JACK. The Recharge times will be slower compared to using the charging station (FR210CS). Note that when recharging all output ports will be disabled.

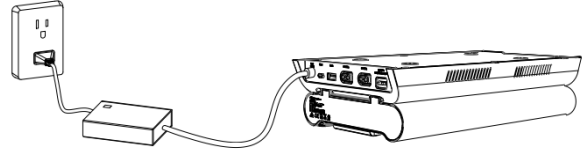

CAUTION

Ensure that the power bank(s) are already docked before plugging in power supply to the DC IN JACK. Plugging in the power supply with no Power Bank(s) docked can damage the dock.

Refer to the below table for recharging times in relation to the number of docked power banks.

1 Unit Docked	2 Units Docked	3 Units Docked
3-4 hours	6-7 hours	8-9 hours

Setting Up FR210I



IMPORTANT

Setting up

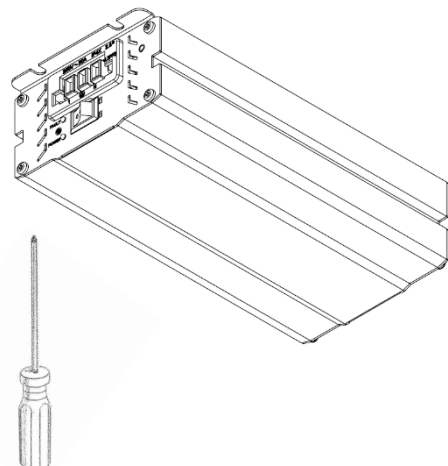

1. Position and screw Inverter (FR210I) into place on the underside of the workstation using 4qty 6G screw (or screw of your choosing). There are 2 screw fixing locations at each end of the inverter.

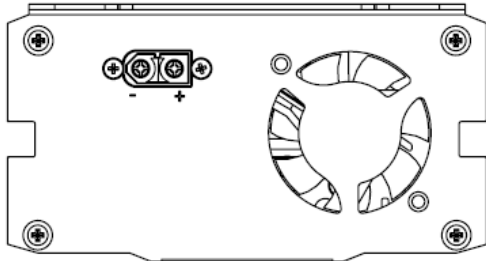

2. Connect the XT60 DC IN via XT60 interconnecting leads to DC OUT 1 on the docking station (FR210DS).

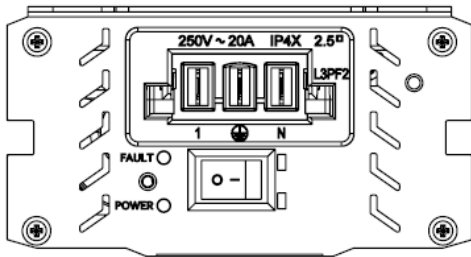

3. Connect the AC out via the TAG Panel Mount at the front of the inverter. Using CMS TAG soft wiring your able to easily connect to CMS products such as SW1804 (inline 4 GPO outlets).



IMPORTANT - Maximum Outputs

The maximum available output of FR210I is directly linked to the output of FR210DS. With 1 Power Bank (FR210PB) docked, Inverter is limited to 240V AC 150W. With 2 or more Power Banks (FR210PB) docked this increases to 300W (350W for 1-2 minutes at a time to operate sit to stand desk). Keep in mind that the total output of the docking station

is shared between both DC OUT ports and USB ports. That's to say, If 100W load was placed on DC OUT 2 and Inverter (FR210I) was plugged into DC OUT 1, The Inverter would only be able to output 200W (250W for 1-2 minutes at a time to operate sit to stand desk) as the total output of FR210DS is 300W.

Using FR210PB Standalone



IMPORTANT – Unboxing

FR210PB will first need to be charged via FR210DS or FR210CS when first unpackaged. Refer 'Using FR210CS'

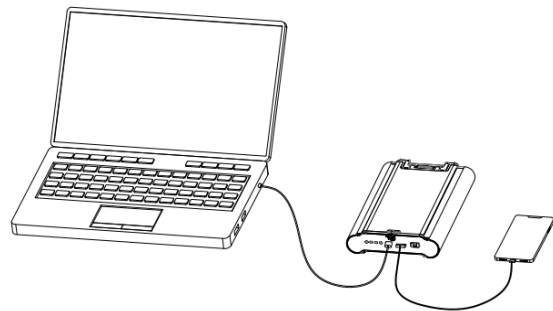



The power bank (FR210PB) can recharge any USB C or USB A compatible device(s). Simply plug in the device and the power bank will auto detect that a device has been plugged in and power on. Four white LED's will illuminate to indicate the power bank's charge level.

The power button can also be pressed to turn on the power bank and display charge level. To turn off the power bank, long press the power button for 10 seconds. The 4 LED's will cycle through 3 times before turning off.

As FR210PB charges your device, each LED will go out systematically until the power bank is depleted.

☀ ☀ ☀ ☀	100% - 75%
● ☀ ☀ ☀	74% - 50%
● ● ☀ ☀	49% - 25%
● ● ● ☀	24% - 1%
● ● ● ●	1 - 0%

 ..FLASH
  ..ON
  ..OFF

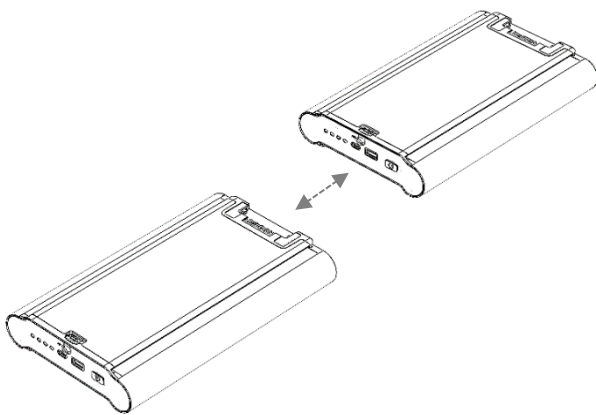

The total capacity of FR210PB can be increased to drastically increase runtimes. This is useful for high powered laptops. Simply slide the second unit into place. You will hear an audible click sound when the units are securely connected.

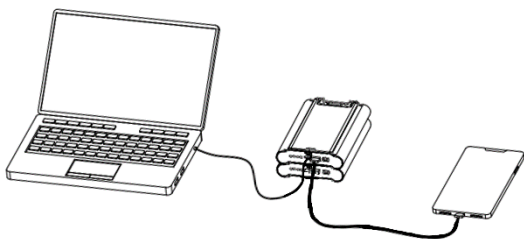

The power bank (FR210PB) on top will become the master unit. The charge level will be displayed via the 4 LED's on the master unit. The second Power Bank will become the slave unit.



IMPORTANT – Slave Unit

If the slave unit power button is pressed in this setup the charge level displayed via 4 LED's may not be correct. USB outputs on the slave unit will be disabled.

To disengage the Power Banks (FR210PB) from each other, simply press the release button or turn the key clockwise direction. If you are having difficulty disengaging the units, you can push the back of the top Power Bank forwards while securely holding the bottom unit and then press the push release button or turn they key. Doing this relieves some of the pressure from the clipping mechanism allowing the units to disengage more easily.

User Maintenance Instructions



IMPORTANT – Cleaning

When cleaning FR210PB, FR210CS, FR210DS & FR210I do not spray cleaner directly onto unit. Spray onto cloth and wipe down the unit. Only spray enough cleaner that the cloth is just damp to the touch.

When cleaning FR210CS or FR210DS disconnect from mains power before wiping down.

When cleaning FR210I, ensure unit is powered off and disconnected from DC IN to prevent risk of electric shock.

User Do's & Don'ts

- Don't exceed maximum output of FR210DS 300W(350W allowed to operate sit to stand desks for 1-2mins at a time).
- Ensure total combined load in within the Maximum output of FR210DS (350W).
- Ensure that the variable voltage switch is set correctly when using this port, if set to incorrect voltage the device been powered may be damaged.
- Don't expose to water or high humidity environment.
- Don't leave outdoors or expose to weather.
- Don't leave sitting in or exposed to direct sunlight.
- Don't operate in hot environment exceeding product operating range.
- Do allow time for FR210PB to cool down before recharging if a large load has been applied to the unit (rapidly discharging) to maintain battery health.
- Do ensure that more than 1 x FR210PB (Power Bank) is docked with FR210DS if load exceeds 150W.

Moving & Storage Instructions



CAUTION – Storage Temperature

As FR210PB contain Lithium-ion batteries; exposure to extreme temperatures, both high and low, can negatively impact their performance and compromise their safety. High temperatures accelerate the aging process and can cause thermal instability, leading to thermal runaway.

Freezing temperatures can cause irreversible damage to the battery's chemistry, reducing its capacity and overall lifespan.

Therefore, storing the Power Bank(s) in a cool and dry environment, away from direct sunlight and heat sources, is vital to maintain their integrity and performance.

Try to store them at a temperature range of between (10~30°C) and humidity of (30~70%).



CAUTION – Physical Damage

Avoid physical damage or stress to the Power Bank(s). Crushing or puncturing the Power Bank(s) can result in internal short circuits, leading to thermal runaway. Store in a safe location away from any risk of being crushed or punctured.



IMPORTANT - Long Term Storage & Maintaining Battery Health

Maintaining an appropriate state of charge during storage is crucial to maintaining battery health. When left in storage the power bank(s) will have a small discharge rate of 0.25mA, over time this will deplete the power bank(s).

Discharge Rate:

-Total Capacity: 3000mAh x 3 (9000mAh)

-PCB Self-discharge current: 0.25mA MAX

As a result, the power bank(s) MUST be recharged every 6 months to maintain cell health.

Disposal of Product



CAUTION

This product contains Lithium-Iron batteries,
Do not dispose of FR210 in general waste.

CMS guarantees to receive these batteries back at the end of its in-use phase for recycling. The service is free and the used batteries need to be delivered by the client to our CMS offices. Otherwise at the end of the product life cycle the freedom unit must be disposed off at an appropriate waste facility.



Troubleshooting

Issue	Cause	Solution/Reason
FR210PB		
All four LED's flashing simultaneously	The over-current protection has activated during discharging.	Remove the over-loading device, the output will recover by pressing the power button or recharging the unit via charging station (FR210CS) to reset.
	The over-temperature protection is activated during charging.	The Unit stopped charging as the device operating temperature has been exceeded. The unit will resume function after returning to operating temperature range.
The power bank cannot be charged.	Check FR210CS is plugged in with power available.	Ensure FR210CS is plugged in with power available LED illuminated.
	12 pin connectors may not be making good contact.	Check that no debris is impeding recharging via the 12-pin connector. Remove and re-add the power bank.
Your plugged-in device(s) are not charging.	There is no capacity left.	Re-charge the power bank.
	The firmware is in protection mode.	Recharge via FR210CS to reset.
	Trying to recharge immediately after rapid discharge.	The temperature of the cells may be too high, battery protection will not allow the unit to charge until cells are at a safe operating temperature. Allow some time for the unit to cool down before attempting to recharge.
Unit run time is low	The capacity left is low	Re-charge the power bank.
	The working current of devices is larger.	Battery degradation over time/usage
	Battery is close to end of life	Battery degradation over time/usage
Unit is Unresponsive	The Unit software is frozen/unresponsive	Press and hold RESET button for 10 seconds (Reset Button located on the underside of the unit).

FR210CS		
Power Available LED not ON	The unit may not be plugged in correctly	Check that the unit is plugged in correctly and power point is active
FR210DS		
4 LED's Fast Flashing	The Over-current protection is activated, for USB A or USB C port is overloaded	Remove the overloading device, the USB port(s) will recover by pressing power button or recharging to reset.
1 Red LED ON	The over-current protection is activated, DC OUT 1 or DC OUT 2 is overloaded	Remove the overloading device(s), Press Power Button to recover. Auto recover will occur after 30 minutes
	The over-current protection is activated, DC OUT 1 or DC OUT 2 is overloads when adjusting height of sit to stand desk (powered by FR210I) when total load on FR210DS has not exceeded 350W	Sit to Stand Desk motors create high inrush current &/or noise that's triggered protection circuit, this can occur on some brands of sit to stand desk motors/units. Press power button to reset. Auto recover will occur after 30 minutes
Unable to output or turn ON	Perhaps the 12-pin connector isn't making good contact	Remove and re-add FR210PB
	12 pin connector made incorrect contact, activated protection.	Recharge to recover (DC IN at rear)
USB C port and DC OUT ports won't provide output simultaneously	2 nd Power Bank (FR210PB) required	Install second Power Bank (FR210PB). If already installed, try removing and readding.
Unable to discharge or recharge	A High rate of discharge has just been applied increasing the temperature of the cells. Over temperature protection activated to protect the cells	Wait for the cells to cool down before attempting to recharge or discharge
4 LED's immediately start to cycle through 3 times before unit turns off after docking FR210PB	Residual charge left in capacitors or FR210DS trigger low power mode and the unit turns off.	Reset by recharging via 20V, 7.5A DC IN
FR210I		
Power Available LED not on	The unit many not be connected to the Docking Station (FR210DS) correctly	Check wiring is correct
	Power Switch is in the OFF position	Switch ON

Red LED Flashing	Input voltage low	240V AC output from inverter may still be available, red LED warning of low input voltage. Power Banks (FR210PB) are low on charge, replace them with fully charged units
Red LED ON, No 240V AC Power Available	Input Voltage too low	Replace Power Banks (FR210PB) with fully charged units
	Inverter protection activated	Switch inverter <u>OFF</u> and <u>ON</u> again
Power Available LED ON, 240V AC output not available	Inverter fault	Switch Inverter <u>OFF</u> and <u>ON</u> again

FR210DS Wiring Example: Mobile Workstation with Sit to Stand

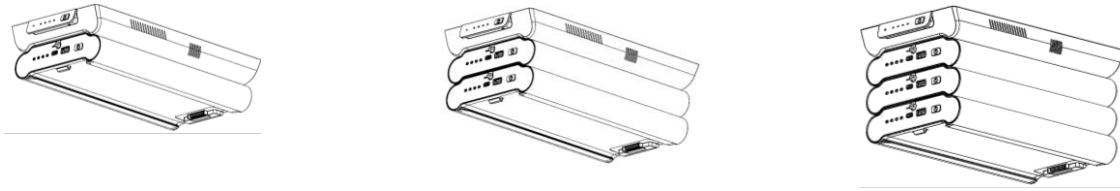

FR210DS with 1x FR210PBP	FR210DS with 2x FR210PBP	FR210DS with 3x FR210PBP
Connected devices: 1 x HP E243i Monitor @ 25W/h (Typical) 1x THD100 @ 60W/h (Typical) 1 x Dell XPS Laptop 1 x Sit to Stand Desk	Connected devices: 1 x HP E243i Monitor @ 25W/h (Typical) 1x THD100 @ 60W/h (Typical) 1 x Dell XPS Laptop 1 x Sit to Stand Desk	Connected devices: 1 x HP E243i Monitor @ 25W/h (Typical) 1x THD100 @ 60W/h (Typical) 1 x Dell XPS Laptop 1 x Sit to Stand Desk
Total Power draw (Typical)= 85W/h	Total Power draw (Typical)= 85W/h	Total Power draw (Typical)= 85W/h
Run time (Typical) calculated $206Wh/85Wh = 2 \text{ hours, } 25min^*$ approx.	Run time (Typical) calculated $412Wh/85Wh = 4 \text{ hours, } 50min^*$ approx.	Run time (Typical) calculated $618Wh/85Wh = 7 \text{ hours, } 16min^*$ approx.

Refer to below wiring diagram for overview of how this type of setup should be wired up. Please note that below wiring diagram may not accurately depict your exact setup and may be used as a reference only.

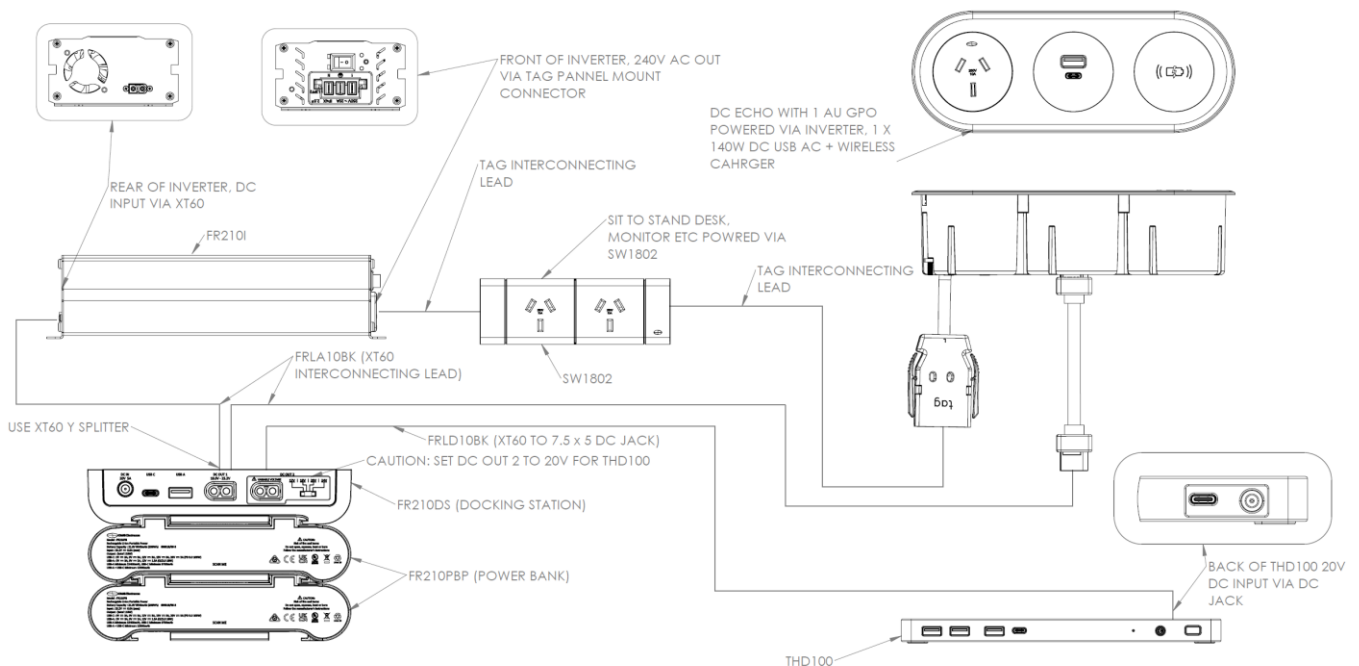

FR210DS Wiring Example: Mobile Flip Table

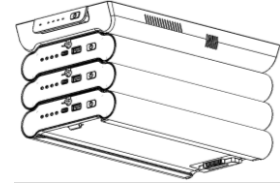
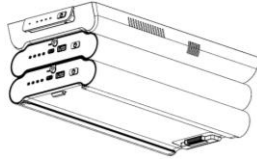
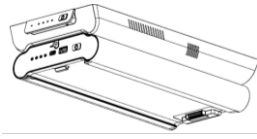

FR210DS with 1x FR210PBP	FR210DS with 2x FR210PBP	FR210DS with 3x FR210PBP
Connected devices: 1 x Echo Duo with 140W USB AC + Wireless Charging Total Power draw (Typical)= 109W/h Total Power Draw (Max) = 149W/h	Connected devices: 1 x Echo Duo with 140W USB AC + Wireless Charging Total Power draw (Typical)= 109W/h Total Power Draw (Max) = 149W/h	Connected devices: 1 x Echo Duo with 140W USB AC + Wireless Charging Total Power draw (Typical)= 109W/h Total Power Draw (Max) = 149W/h
Run time (Typical) 206Wh/109Wh = 1 hour, 52min* approx.	Run time (Typical) 412Wh/109Wh = 3 hours, 46min* approx.	Run time (Typical) 618Wh/109Wh = 5 hours, 39min* approx.
Run time (Max) 206Wh/149Wh = 1 hour, 22min* approx.	Run time (Max) 412Wh/149Wh = 2 hour, 45min* approx.	Run time (Max) 618Wh/149Wh = 4 hours, 8min* approx.

Refer to below wiring diagram for overview of how this type of setup should be wired up. Please note that below wiring diagram may not accurately depict your exact setup and may be used as a reference only.

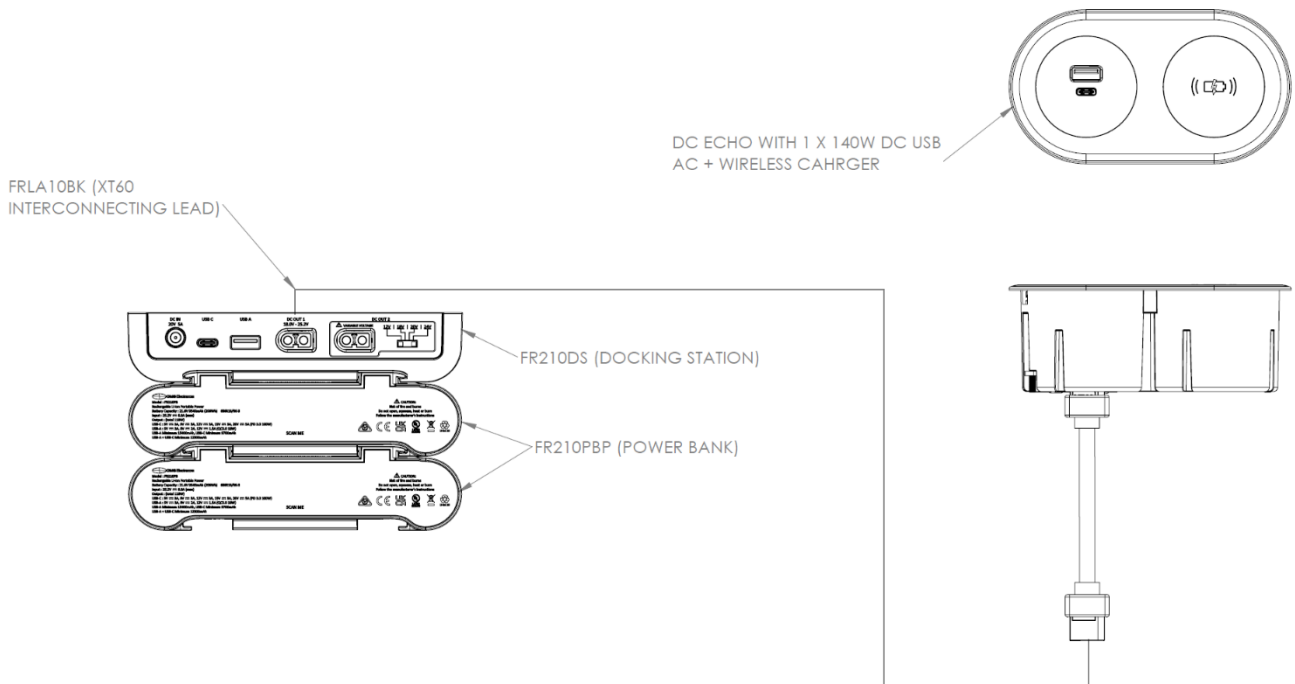

FR210DS Wiring Example: Desk or in Furniture

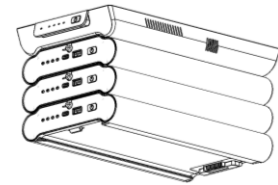
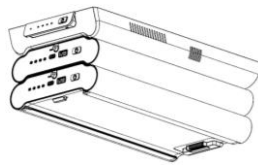
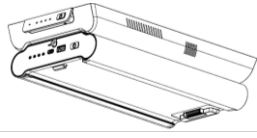

FR210DS with 1x FR210PBP	FR210DS with 2x FR210PBP	FR210DS with 3x FR210PBP
Connected devices: 1 x Echo Duo with 140W USB AC + Wireless Charging (69W/h Typical, 149W/h Max) 1 x AU Socket (Up to 300W) Total Power draw (Typical)= 109W/h Total Power Draw (Max) = 149W/h	Connected devices: 1 x Echo Duo with 140W USB AC + Wireless Charging (69W/h Typical, 149W/h Max) 1 x AU Socket (Up to 300W) Total Power draw (Typical)= 109W/h Total Power Draw (Max) = 149W/h	Connected devices: 1 x Echo Duo with 140W USB AC + Wireless Charging (69W/h Typical, 149W/h Max) 1 x AU Socket (Up to 300W for laptop chargers, monitors etc.) Total Power draw (Typical)= 109W/h Total Power Draw (Max) = 149W/h
Run time (Typical) 206Wh/69Wh = 1 hour, 52min* approx.	Run time (Typical) 412Wh/69Wh = 3 hours, 46min* approx.	Run time (Typical) 618Wh/69Wh = 5 hours, 39min* approx.
Run time (Max) 206Wh/149Wh = 1 hour, 22min* approx.	Run time (Max) 412Wh/149Wh = 2 hour, 45min* approx.	Run time (Max) 618Wh/149Wh = 4 hours, 8min* approx.
Run time (With AU Socket) 69Wh (Echo Typical Load) + 239Wh (AU Socket) = 300Wh Total Load 206Wh/300Wh = 0 hours, 40min* approx.	Run time (With AU Socket) 69Wh (Echo Typical Load) + 239Wh (AU Socket) = 300Wh Total Load 412Wh/300Wh = 1 hours, 22min* approx.	Run time (With AU Socket) 69Wh (Echo Typical Load) + 239Wh (AU Socket) = 300Wh Total Load 618Wh/300Wh = 3 hours, 3min* approx.

Refer to below wiring diagram for overview of how this type of setup should be wired up. Please note that below wiring diagram may not accurately depict your exact setup and may be used as a reference only

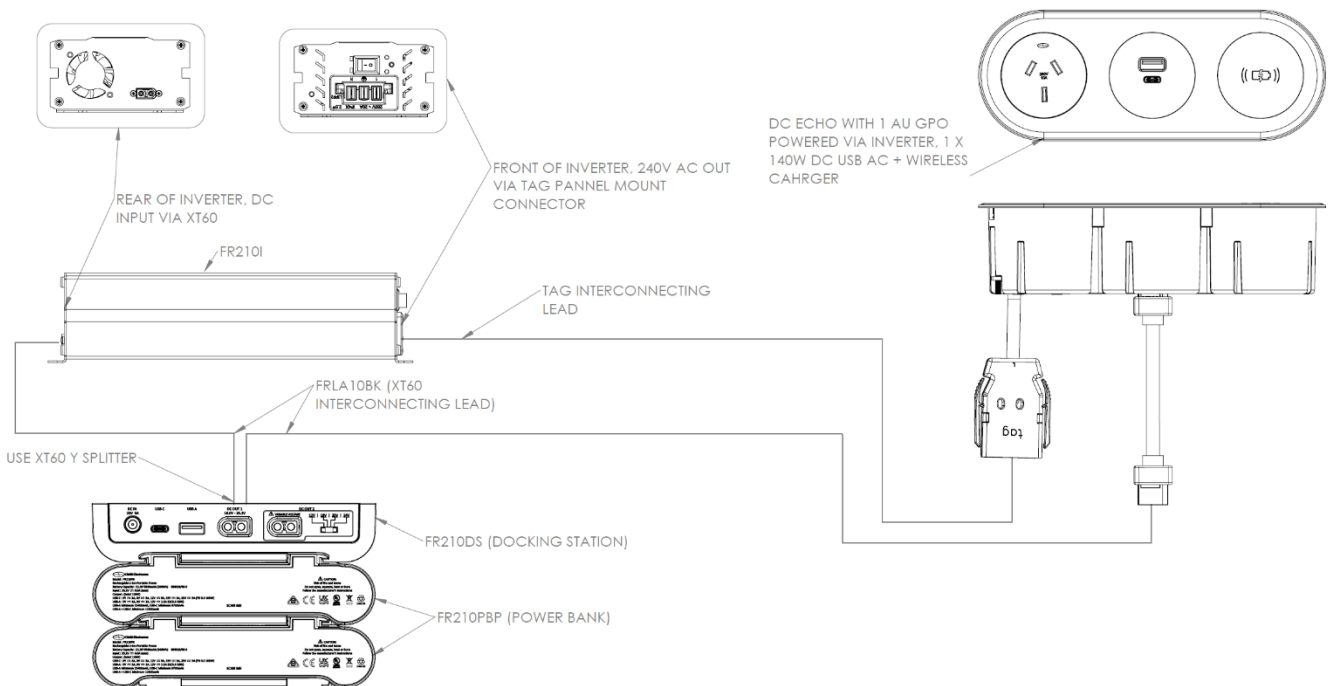

FR210 Estimated Runtimes*

Below are calculated run times for various setups of the freedom product range including an industry standard laptop and monitor. Please note that the below times were calculated using 1 FR210PB, if using 2, double the results, if 3, triple. Laptop used for this test Dell XPS 13". Monitor used for this test Dell U2417H 24". Note calculations assume 100% efficiency, real world losses not taken into account.

140W DC USB	15W DC Wireless	THD100	Boost Wireless Charger	Quantum Wireless Charger	Inverter	Sit to Stand Desk	Dell Monitor	Dell Laptop	Stand-by Draw	Stand-by Run Times	Draw	Use Run Times
X									0.10W	2060 hour	140W(MAX)	1 hour 28mins
	X								0.37W	556 hours 45 mins	9W	22 hours 52mins
		X							2.27W	90 hours 44mins	150W(MAX)	1 hours 22mins
			X									
				X					0.55W	374 hours 54mins	38.1W(MAX)	5 hours 24mins
					X				7W	29 hours 29mins	300W(MAX)	40min
					X	X			7W	29 hours 25mins	225W	54min
					X		X		8W	25 hours 45mins	25W(MAX)	8 hours 14mins
X								X			40W	5 hours 9mins
X	X	X			X		X	X	16W	12 hours 52mins	128W	1 hour 36mins
X	X				X	(18mins of operation)		X	9W	22 hours 52mins	140W (+ 300W via Sit to Stand for 18mins total operation)	0 hours 49mins
X	X								0.47W	438 hours 17mins	149W(MAX)	1 hour 22mins