

NOTE:

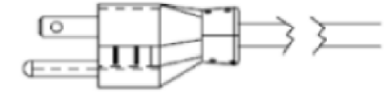

CABLE TYPE: 3 CORE x 2.08mm² (14AWG)
 DESCRIPTION: US PLUG LEAD
 COLOUR: WHITE OR BLACK
 (REFER TO PURCHASE ORDER)

x	LENGTH
A	1.5FT (457.2mm)
B	3.0FT (914.4mm)
C	4.0FT (1219.2mm)
D	5.0FT (1524mm)
E	6.0FT (1828.8mm)
F	8.0FT (2438.4mm)
G	10.0FT (3048mm)
H	12.0FT (3657.6mm)
I	15.0FT (4572mm)
J	18.0FT (5486.4mm)
K	21.0FT (6400.8mm)
L	24.0FT (7315.2mm)

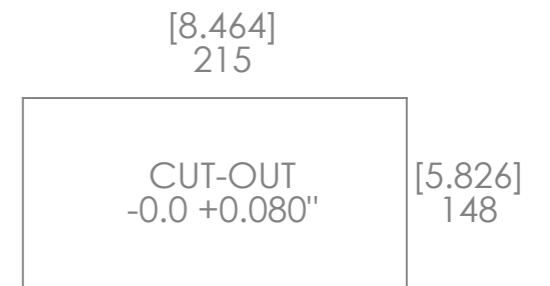
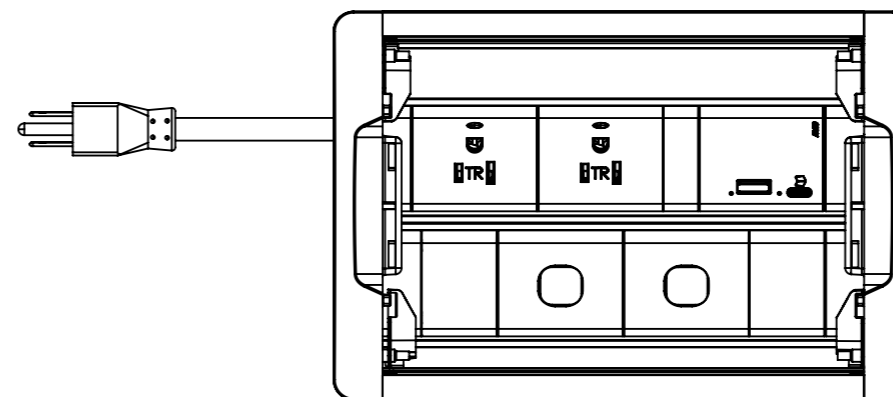
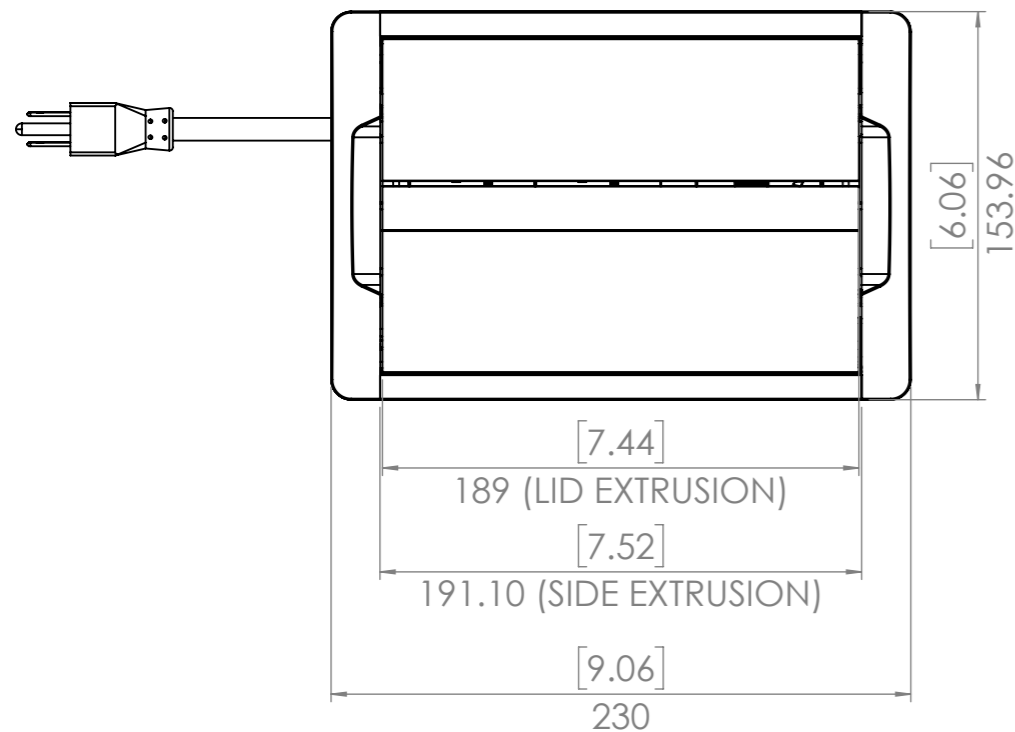
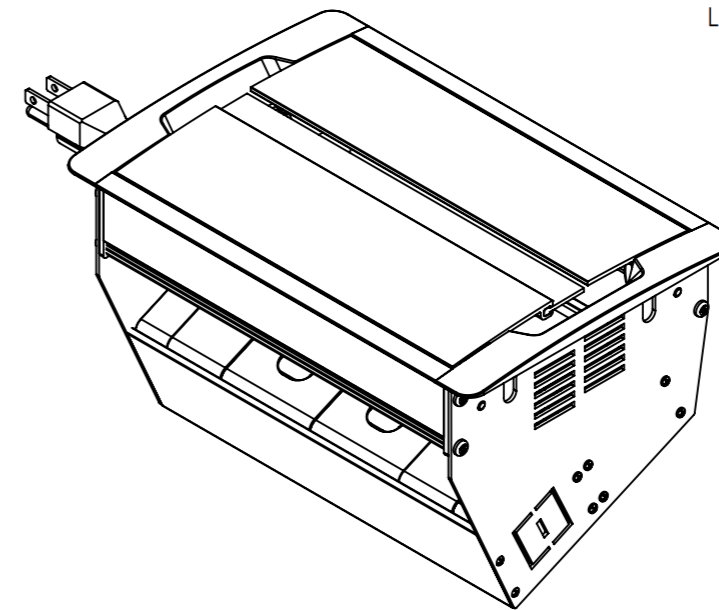
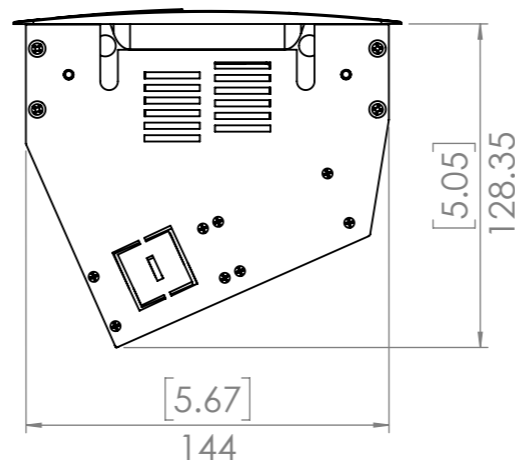
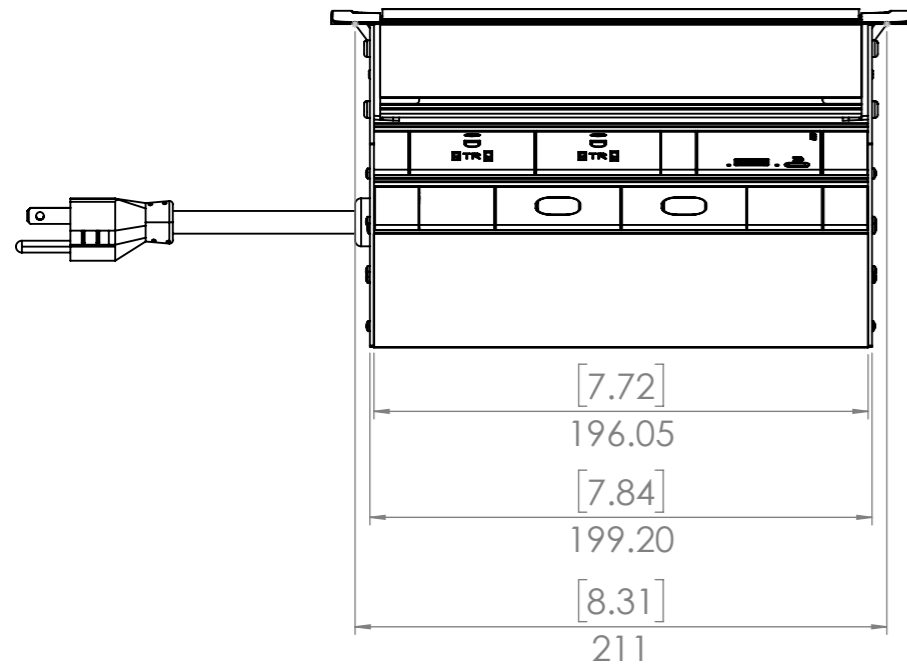

PART NUMBER: 1ACD2U5C2xxXX

NOTE - xx - LENGTH - A / B / C / D / E / F / G / H / I / J / K / L
 XX - COLOUR - WT / BK

CUSTOMER SIGNATURE:		CMS Electracom COPYRIGHT © 2015				
MATERIAL:	POLYCARBONATE / ALUMINIUM TOLERANCES UNLESS OTHERWISE STATED: X ±0.5 X.X ±0.2 X.XX ±0.1 X.XXX ±0.05 ANG ±0.5°					
FINISH:	FINE EDM / ANODISED					
COLOUR:	VARIOUS	TITLE: ACCEDE DUAL LID WITH 2 US SOCKETS + SW18UAC65FL + 2 DATA DRAWING: LU48377 SCALE 1:3				
1	RELEASED FOR PRODUCTION	13/5/2025	JB	AP	1	A3
REV	DESCRIPTION	DATE	DRWN	APPV		
REVISIONS				SHEET 1 OF 3		

1	RELEASED FOR PRODUCTION	13/5/2025	JB	AP
REV	DESCRIPTION	DATE	DRWN	APPV
REVISIONS				

THIS DRAWING & ASSOCIATED CAD FILES ARE ISSUED IN THE STRICTEST CONFIDENCE AND ARE ONLY TO BE USED IN THE COMMERCIAL INTERESTS OF CMS ELECTRACOM PTY LTD

DRAWN IN mm TO AS1100 DO NOT SCALE

CMS Electracom
 cmselectra.com
Max rated output: 15A, 120V~, 50Hz
 USB input (if fitted): 0.8 - 2.0A
 Model: SW18UAC65FL
 Port 1 Output Max 18W - 12V/1.5A
 Port 2 Output Max 65W-20V/3.25A
 Wireless charger (if fitted) 15W
CAUTION: to reduce risk of electric shock use only indoors (for use only in portable furnishing)



MODEL: XXXXXXXXXX
BUILT: X XXXX

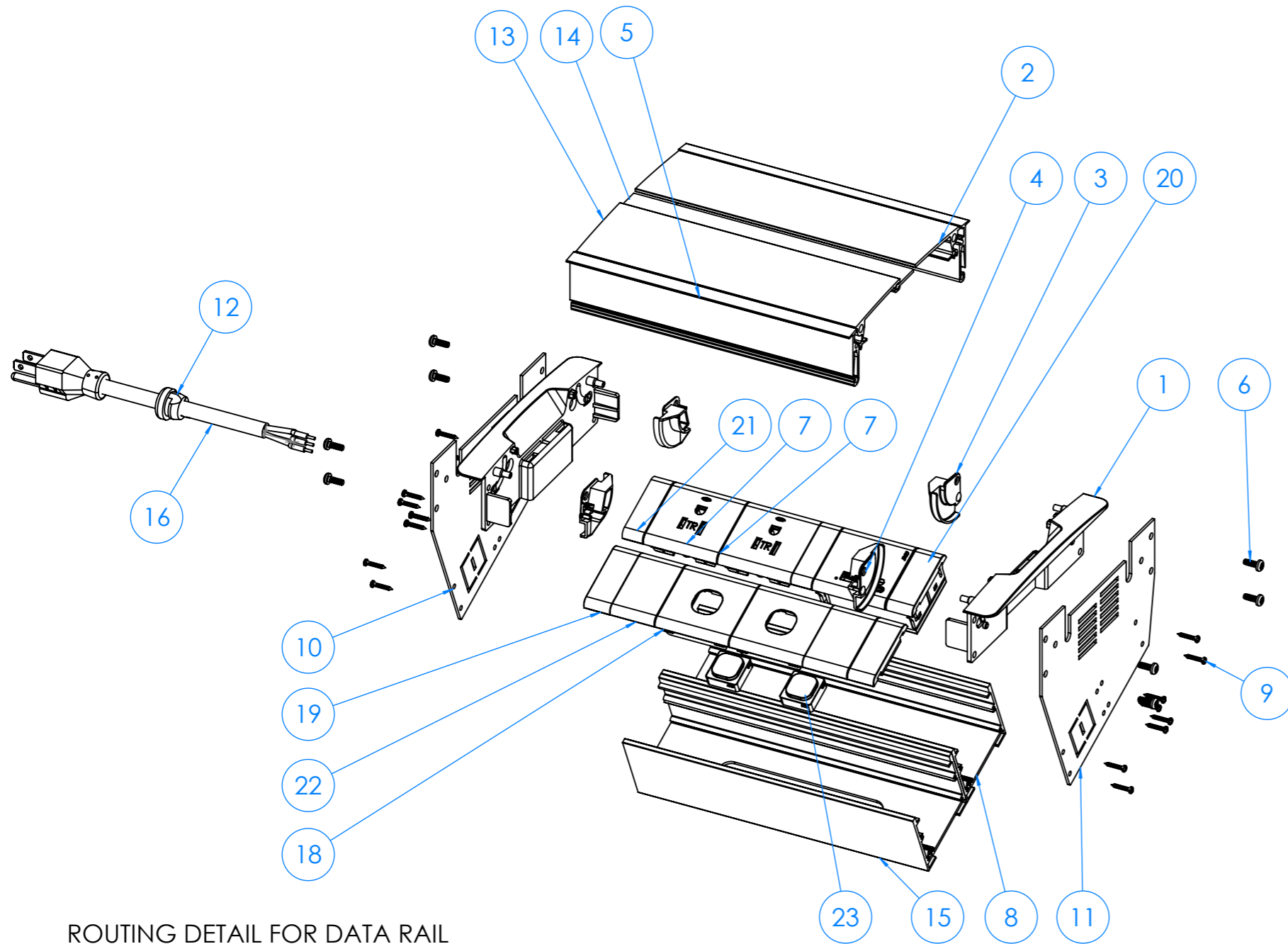

ITEM NO.	PART NUMBER	DESCRIPTION	QTY.
1	LU7913-2	END CAP	2
2	LU21534	DUAL LID EXTRUSION 189MM	1
3	LU7914 - RH	RIGHT HAND CABLE RELIEF	2
4	LU7914 - LH	LEFT HAND CABLE RELIEF	2
5	LU7916	LID SIDE EXTRUSION 191.1MM	2
6	7021603	6G X 3/8" PAN HEAD SELF TAPPING SCREW	8
7	LU33408	DUBUSRW US SOCKET WITH SHUTTER	2
8	LU9340	196.0mm ZEUS 2 EXTRUSION	1
9	7021204	2G x 1/2" Pan Head Self Tapping Screw	16
10	LU27626	ACCEDE DUAL US LH SIDE PLATE	1
11	LU27184	ACCEDE DUAL US SIDE PLATE	1
12	HEYCO 7N-2	HEYCO 7N-2 GROMMET	1
13	LU9503	ACCEDE DUAL LID EXTRUSION - WITH BRUSH STRIP - 189mm	1
14	9010930	BRUSH STRIP - 189mm	1
15	LU9340	196.0mm ZEUS 2 EXTRUSION WITH DATA ROUTING	1
16	LEAD	REFER TO NOTES	1
18	SW18C1	50mm SINGLE DATA TILE	2
19	SW18A CDG	18mm BLANK TILE	2
20	LU37592	SW18UAC65FL 65W USB CHARGER HARDWIRED	1
21	14mm TRIMED SW18A CDG	14mm TRIMED SW18A CDG	2
22	30mm SW18C+ TRIMMED	30mm SW18C+ TRIMMED	2
23	BPM	BPM	2

ROUTING DETAIL FOR DATA RAIL

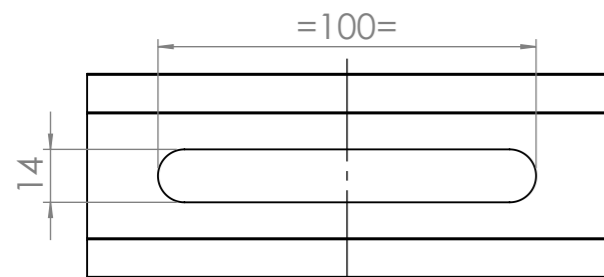

ZEUS DATA EXIT CUTOUT TO SUIT 2 X DATA

CUSTOMER SIGNATURE:		CMS Electracom COPYRIGHT © 2015	
MATERIAL: POLYCARBONATE / ALUMINIUM	TOLERANCES UNLESS OTHERWISE STATED: X ±0.5 X.X ±0.2 X.XX ±0.1 X.XXX ±0.05 ANG ±0.5°	TITLE: ACCEDE DUAL LID WITH 2 US SOCKETS + SW18UAC65FL + 2 DATA	
FINISH: FINE EDM / ANODISED		DRAWING: LU48377	REV: 1
COLOUR: VARIOUS		A3	
THIS DRAWING & ASSOCIATED CAD FILES ARE ISSUED IN THE STRICTEST CONFIDENCE AND ARE ONLY TO BE USED IN THE COMMERCIAL INTERESTS OF CMS ELECTRACOM PTY LTD		SCALE: 1:4	SHEET: 2 OF 3

WIRING DIAGRAM:-

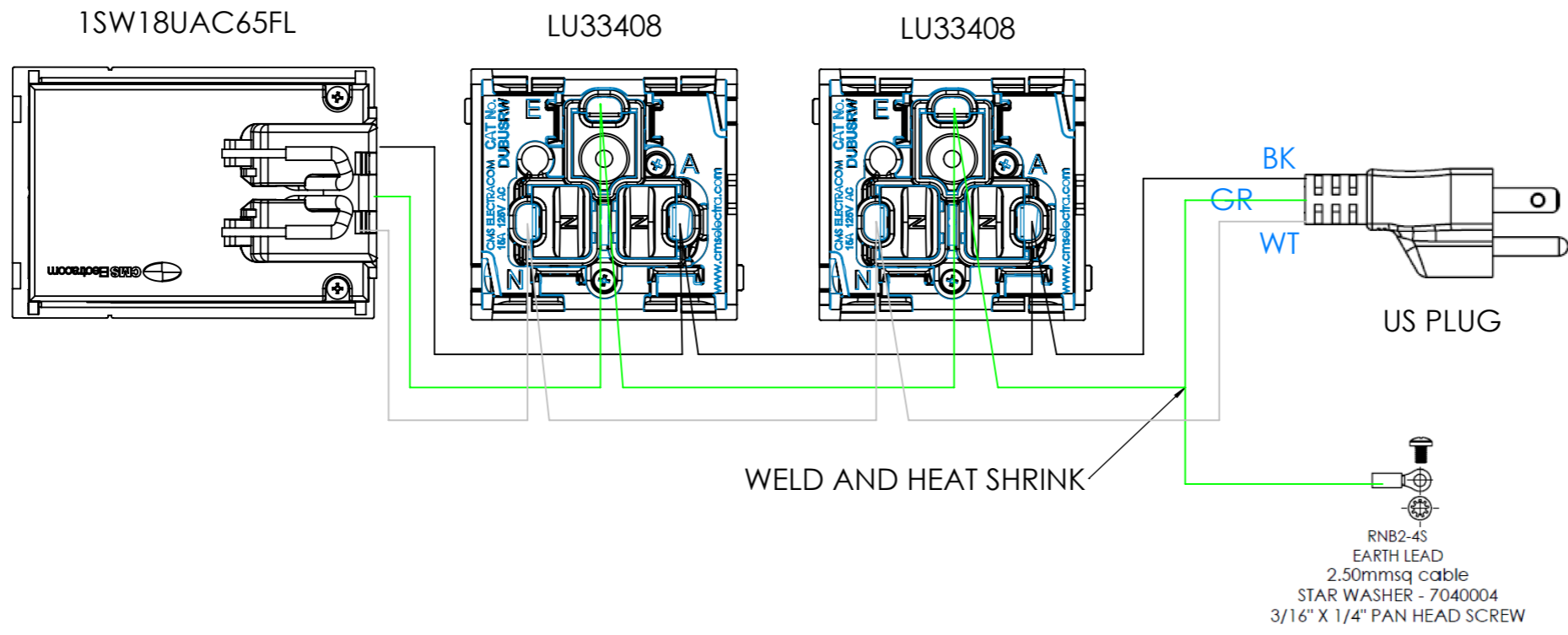

- NOTE -
 BK - BLACK - LIVE (CONNECTED TO NEUTRAL FOR UNIVERSAL SOCKET)
 GR - GREEN - EARTH
 WH - WHITE - NEUTRAL (CONNECTED TO LIVE FOR UNIVERSAL SOCKET)
 NOTE -
 1) ALL STRIPPED WIRE HAVE 7mm FERRULE (PART NO - 6051507)
 2) LIVE & NEUTRAL SWAPPED FOR INTERNATIONAL SOCKET, BECUASE OF US PLUG.

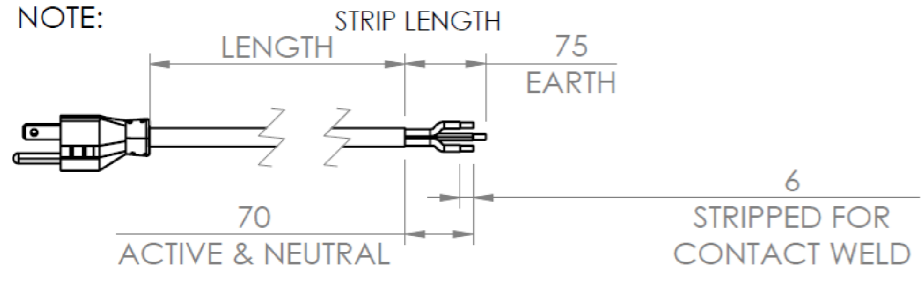

NOTE:
 CABLE TYPE: 3 CORE x 2.08mm²
 DESCRIPTION: US PLUG TO GPO CONTACTS
 LENGTH: REFER TO PURCHASE ORDER
 COLOUR: WHITE OR BLACK (REFER TO PURCHASE ORDER)

CUSTOMER SIGNATURE:	TOLERANCES UNLESS OTHERWISE STATED:	CMS Electracom COPYRIGHT © 2020
MATERIAL: POLYCARBONATE / ALUMINIUM	X ±0.5 X.X ±0.2 X.XX ±0.1 X.XXX ±0.05 ANG ±0.5°	
FINISH: FINE EDM / ANODISED		
COLOUR: VARIOUS		
THIS DRAWING & ASSOCIATED CAD FILES ARE ISSUED IN THE STRICTEST CONFIDENCE AND ARE ONLY TO BE USED IN THE COMMERCIAL INTERESTS OF CMS ELECTRACOM PTY LTD		TITLE: ACCEDE DUAL LID WITH 2 US SOCKETS + SW18UAC65FL + 2 DATA
DRAWN IN mm TO AS1100 DO NOT SCALE		DRAWING: LU48377
		REV: 1
		SCALE 2:1
		SHEET 3 OF 3
		A3