

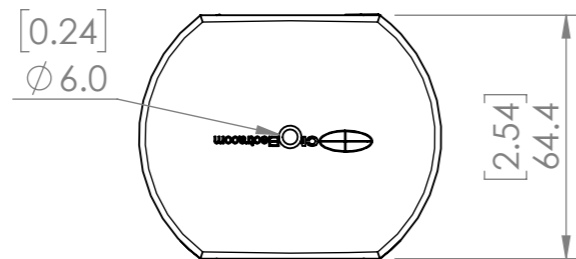

COLOUR VARIATIONS		
PART NUMBER	PLASTIC COMPONENTS	EXTRUSION
WT	WHITE	ANODISED SILVER
BK	BLACK	ANODISED SILVER
BK/BK	BLACK	POWDERCOATED BLACK MANNEX
WT/WT	WHITE	POWDERCOATED WHITE SATIN
WT/WM	WHITE	POWDERCOATED WHITE MANNEX

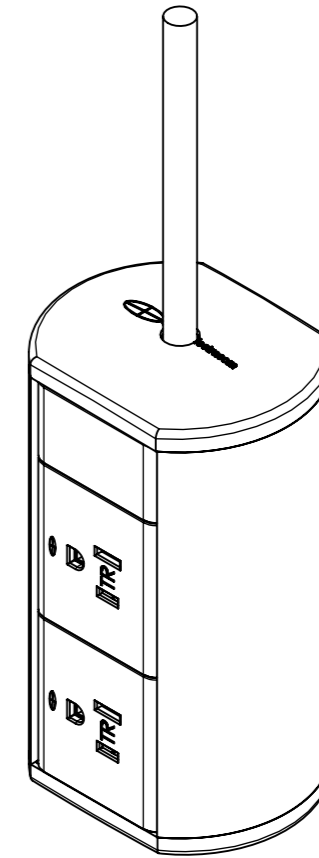
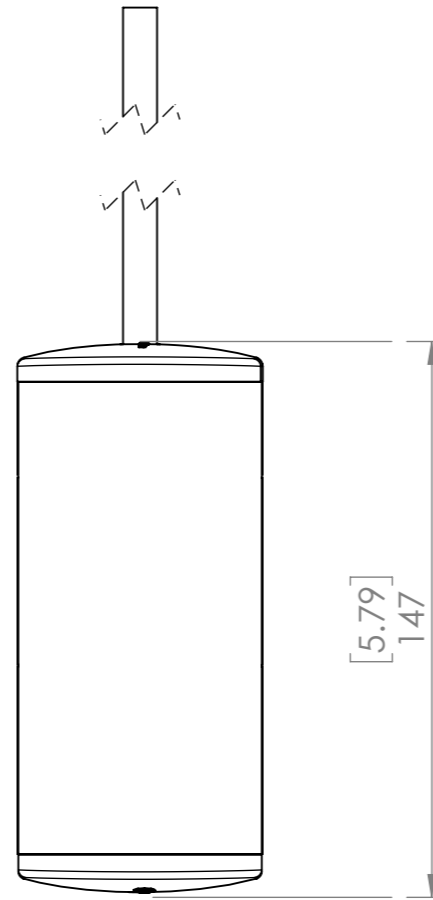
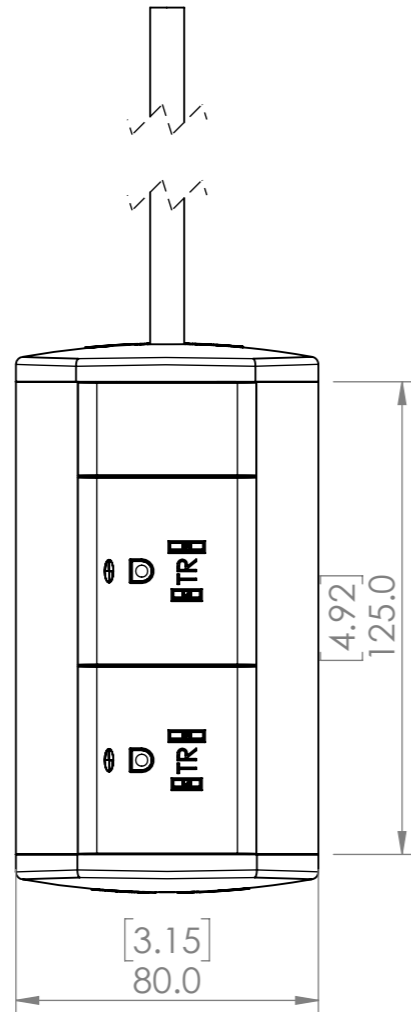

**PART NUMBER:** xxXX

NOTE - xx - LENGTH - 05 / 10 / 15 / 20 / 25 / 30 / 35 / 40 / 45 / 50  
 XX - COLOUR - WT / BK / (BK/BK) / (WT/WT) / (WT/WM)

<b>CUSTOMER SIGNATURE:</b>	<b>TOLERANCES UNLESS OTHERWISE STATED:</b>  X ±0.5 X.X ±0.2 X.XX ±0.1 X.XXX ±0.05 ANG ±0.5°	 <b>CMS Electracom</b> COPYRIGHT © 2015		
<b>MATERIAL:</b> ALUMINIUM / POLYCARBONATE				<b>TITLE:</b> US POWER POLE FOR ELEVATE 4 GPO
<b>FINISH:</b> FINE EDM / ANODISED (POWDER COAT)		<b>DRAWING:</b> LU48505	<b>REV:</b> 1	
<b>COLOUR:</b> REFER TABLE	DRAWN IN mm TO AS1100 DO NOT SCALE		SCALE 1:2	SHEET 1 OF 3
THIS DRAWING & ASSOCIATED CAD FILES ARE ISSUED IN THE STRICTEST CONFIDENCE AND ARE ONLY TO BE USED IN THE COMMERCIAL INTERESTS OF CMS ELECTRACOM PTY LTD				

1	RELEASED FOR PRODUCTION	26/05/2025	SP	AP
REV	DESCRIPTION	DATE	DRWN	APPV
REVISIONS				